

GRF-250 laser rangefinder

The world's smallest and lightest
250-meter laser rangefinder.



Disclaimer

Information found in this document is used entirely at the reader's own risk and whilst every effort has been made to ensure its validity, neither LightWare Optoelectronics (Pty) Ltd, its subsidiaries, nor its representatives make any warranties with respect to the accuracy of the information contained herein.



FM 654831



Welcome to LightWare

Thank you for selecting LightWare as your **partner** in distance sensing technology.

LightWare is a pioneer in microLiDAR® distance sensors and laser rangefinders (LRF), drawing upon **four decades** of expertise in LiDAR technology to develop application-specific products renowned for their **accuracy, reliability, and durability**. LightWare's assembly process involves meticulous handling of sensors and optics, creating sensors of world class quality. Our production methods benchmark the **ISO 9001:2015** standards at scale, with manufacturing capabilities reaching up to **45,000 units annually**, with each LRF unit crafted to the same exacting standards. Unsurprisingly, leading companies worldwide trust LightWare as their **preferred LRF partner**.

We are dedicated to ensuring **your success** when using LightWare laser rangefinders to address your unique distance measuring and geospatial challenges.

Beyond this comprehensive product guide, our website's **resource center** (<https://lightwarelidar.com/>) offers a wealth of supplementary information, **including APIs, CAD drawings, and FAQs**.

Our dedicated technical support desk is at your service if you require assistance with integration or technical queries. Reach out to them at support@lightwarelidar.com.

LightWare products come with a **24-month limited warranty**, covering any defects in material or workmanship under normal use. For detailed warranty information, please refer to our website at <https://lightwarelidar.com/terms-and-conditions/>. We're here to support you on your journey — sensing your world with LightWare LiDAR.



Table of contents

1	Overview	5
2	Safety	6
2.1	Laser eye safety.....	6
2.2	Labeling	7
2.3	Laser radiation information.....	7
3	Key technical specifications	8
4	Accessories	9
4.1	USB cable	9
4.2	Communication cable.....	9
4.3	Pixhawk adapter.....	10
4.4	Breakout board	10
5	Getting started.....	11
6	Parameters, filters, settings and tools.....	15
6.1	Setting the device parameters	15
6.2	Filters	17
6.3	Settings and tools.....	18
7	Installation, mounting, and cabling	19
7.1	Mechanical interface.....	19
7.2	Mounting and alignment instructions	20
7.3	Orientation.....	21
7.4	Communication and power cable	22
8	Advanced features	23
8.1	Five distance output	23
8.2	First and last pulse detection.....	23
8.3	Sleep mode	24



8.4	Alarms.....	24
9	Communications interfaces.....	25
9.1	Serial UART interface.....	25
9.2	I ² C interface.....	26
10	Commands.....	26
10.1	Command structure.....	27
10.2	Checksum algorithm.....	28
10.3	Reading bytes.....	29
10.4	Sending commands.....	30
10.5	Saving.....	30
10.6	Command list.....	31
11	Firmware updates.....	36
12	Troubleshooting.....	38
13	Repair and maintenance.....	39
13.1	Maintenance and calibration.....	39
13.2	Cleaning.....	39
13.3	Electrical safety.....	39
13.4	Service and repairs.....	40
14	End-of-life safe disposal.....	41
15	Document revision history.....	42



1 Overview

This product guide is a comprehensive companion to your LightWare GRF-250 laser rangefinder, a groundbreaking **250-meter sensor** renowned as the world's smallest and lightest in its category. Meticulously engineered to **seamlessly integrate** into **electro-optical/infrared (EO/IR) gimbals**, it sets new standards in distance sensing for precise camera focus and relative object positioning.

By incorporating the GRF-250 into your EO/IR gimbal, you gain access to critical **depth perception data**, allowing for optimal long-range camera focus and ensuring a crystal-clear image. Additionally, it unlocks **precise localization** of observed objects, even enabling the **triangulation** of the object's **GPS coordinates**.

GRF-250 is a compact, ultralight, and energy-efficient sensor that utilizes the **time-of-flight principle** to measure distance by emitting a rapid succession of laser pulses that are reflected by target objects and received back and immediately processed. It uses **905-nanometer laser technology**, ensuring optimal performance at an affordable price, while meeting **class 1M eye safety** standards. The GRF-250's accuracy is **not affected by the color or texture** of the target or object surface or the laser beam's angle of incidence. It is virtually immune to background light, wind, and noise, rendering it an ideal sensor for outdoor use.

Configurable features and versatile hardware make the GRF-250 easy to integrate. With a 250-meter laser rangefinder, the GRF-250 extends your sensing horizon, delivering reliable performance over long distances. **Measuring a mere 32 mm x 34 mm x 21 mm**, this sensor is meticulously designed for seamless integration into space-constrained gimbals, ensuring versatility without compromise. Weighing **just 10.7 grams**, the GRF-250 sensor stands as the epitome of ultralight design, making it the ideal sensor for gimbals used in demanding applications with strict weight constraints.



Figure 1: Front and side view of the GRF-250



2 Safety

Always adhere to these product safety precautions and operate the sensor strictly following the guidelines outlined in this product guide. LightWare bears no responsibility or liability for any damage or injury, whether direct or indirect, arising from a failure to comply with these stipulations. Non-compliance with the precautions or warnings provided in this product guide constitutes a breach of safety standards intended for the proper use of the sensor.

2.1 Laser eye safety

LightWare LiDAR sensors comply with the United States Food and Drug Administration (FDA) laser eye safety regulations for safe use around humans and animals, based on the international standard IEC 60825-1 and utilizing LaserSafe PC Professional for the computations.

Caution: The LRF contains a laser and should never be aimed at a person or animal. Do not view the laser with magnifying optics such as microscopes or telescopes.

This laser product emits non-ionizing laser radiation. It is classified as Class 1M, indicating that the laser beam is safe to look at with the naked eye during normal use. However, avoid viewing it through magnifying optics such as binoculars, microscopes, telescopes, etc. Despite the safety rating, refrain from looking into the beam, switch off the device when in the vicinity, and never stare directly into the lens from less than half a meter.

Caution: Use of controls, adjustments, or performance of procedures other than those specified herein may result in hazardous radiation exposure.

Warning: Risk of permanent eye damage

- Class 1M lasers are **unsafe** if viewed through **magnifying optics such as microscopes, binoculars, or telescopes from a distance less than the NOHD.**
- The laser eye safety rating of the LRF depends on the mechanical integrity of the optics and electronics. It must **not be disassembled or modified in any way.**
- **If the LRF sensor is damaged, do not continue using it.**
- The LRF sensor should be mounted using the mounting holes. **Do not attach to or clamp the lens tubes**, which may cause damage and adversely affect the laser safety rating.
- There are **no user-serviceable parts**, and maintenance or repair must only be done by the manufacturer or a qualified service agent.
- No regular maintenance is required, but if the lenses start collecting dust, they may be wiped with suitable lens-cleaning materials. Ensure that the device is switched off before looking into the lenses.



2.2 Labeling

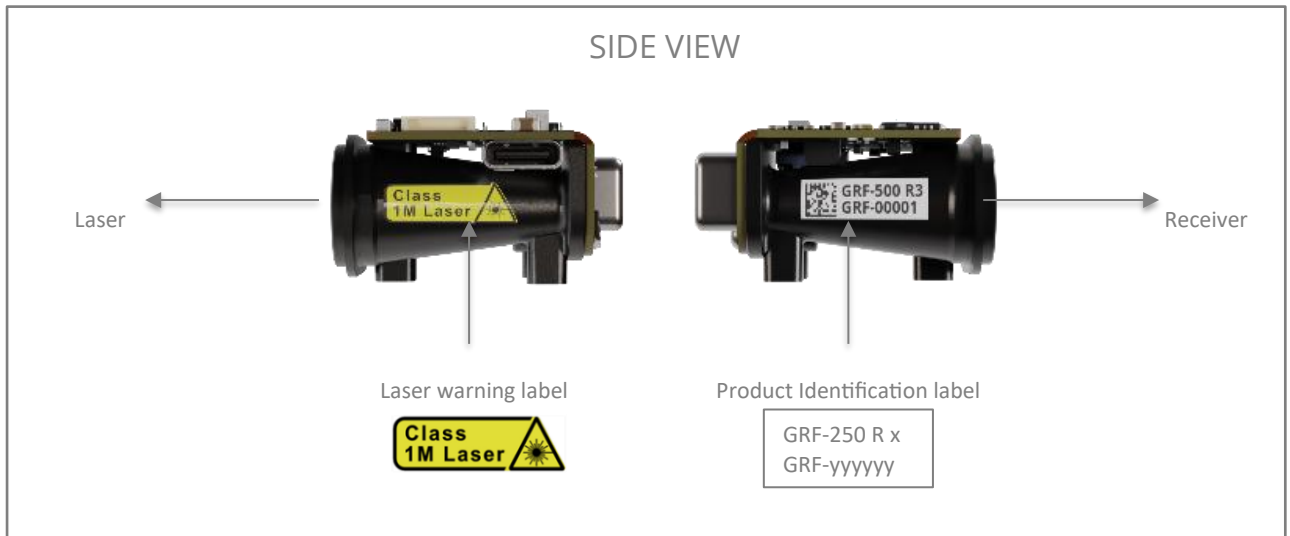

Figure 2: GRF-250 laser warning label

Important note: It is a legal requirement to display the laser warning label on your final product or system. To assist with this, LightWare has included an extra laser warning label in the packaging.

2.3 Laser radiation information

Table 1: Laser radiation information

Specification	Value
LightWare product	GRF-250 laser rangefinder
LiDAR type	Static single beam
Eye safety classification	Class 1M
Laser wavelength	905 nm
Pulse width	36 ns
Pulse frequency	20 kHz
Average power	2.0 mW
Maximum energy per pulse	100 nJ
Extended Nominal Ocular Hazard Distance (NOHD)*	29 m / 95.1 ft

* Distance beyond which binoculars may be safely used.

Approximate values only. Please contact LightWare LiDAR if further information is required.



3 Key technical specifications

Table 2: GRF-250 laser rangefinder key technical specifications

GRF-250 laser rangefinder key technical specifications	
Performance	
Range	0.2 to 250 m / 0.6 to 820.2 ft (at 50 Hz update rate, 40% albedo, 10 km visibility, 1.4 x 1.4 m target size)
Update rate	1 to 50 readings per second (customizable to suit application)
Resolution	0.1 m / 0.32 ft
Accuracy	± 50 cm / ± 19.6 in (1 sigma)
False alarm rate	<1%
Target discrimination	20 m on same type targets
Multiple targets	Max 5
Connections	
Power supply voltage	4.5 to 5.5 V
Power supply current	120 mA (typical) 250 mA (surge at startup)
Outputs and interfaces	Serial UART and I ² C (3.3 V TTL, 5 V tolerant)
Form factor	
Dimensions	32 mm x 34 mm x 21 mm / 1.3 in x 1.4 in x 0.8 in
Weight	10.7 g / 0.377 oz (excluding cables)
Optical	
Approvals	FDA Accession: 2411673-000 (2024/09) ROHS3 Compliant REACH unaffected CE (designed for, scheduled for testing) NDAA compliant (Section 848) Blue UAS ready
Laser safety	Class 1M (Please refer to the eye safety section of this user guide, above)
Optical aperture	12.7 mm / 0.5 in
Beam divergence	< 0.5°
Mechanical boresight	±1.5° with respect to mechanical interface
Environmental	
Operating temperature	-20 to 60°C / -4 to 140°F
Storage temperature	-40 to 80°C / -40 to 176°F
Enclosure rating	Front face is IP67. Unit has no rating (IP00 full unit)
Accessories	
USB cable	USB2.0_C_M/M
Communication cable	A08SUR08SUR32W102A
Pixhawk adapter	SKU: ACC_PX_08SUR-32S
Breakout board	SKU: ACC_BOB_08SUR-32S
Default settings	
Serial port settings	Baud rate 115200, 1 start bit, 1 stop bit, no parity
I ² C address	0x66 (Hex), 102 (Dec)
Update rate	5 readings per second



4 Accessories

To support configuration and integration, the following GRF-250 accessories are available for purchase from the LightWare website:

4.1 USB cable

To configure and test your LRF via LightWare Studio, a USB cable is needed. A USB 2.0 with a data transfer rate of 480 Mbps or more is recommended.

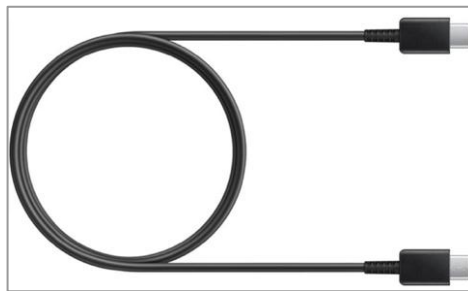

Figure 3: USB2.0_C_M/M USB cable for GRF-250

4.2 Communication cable

Each GRF-250 is supplied with a communication and power cable. Additional cables are available for purchase from our online store.



Figure 4: A08SUR08SUR32W102A - Communication cable for GRF-250



4.3 Pixhawk adapter

To use your GRF-250 laser rangefinder as an autopilot sensor for above ground level (AGL) or obstacle detection, a Pixhawk adapter is available:

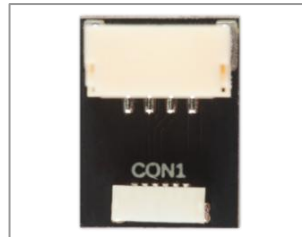

Figure 5: ACC_PX_08SUR-32S adapter for GRF-250

4.4 Breakout board

An optional breakout board accessory is available to facilitate the integration of the LRF into a host controller such as a Pixhawk, PX4, Raspberry Pi, Arduino, etc. It consists of four reusable adapter boards to conveniently connect the GRF-250 communication cable to other standard cables and host controllers, without requiring soldering.

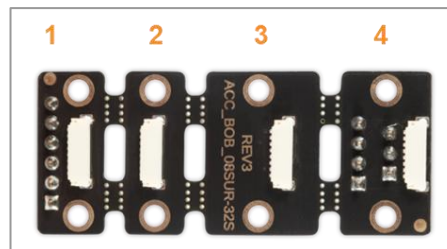

Figure 6: ACC_BOB_08SUR-32S breakout board for GRF-250

Table 3: Breakout board sub-boards

Board 1	Six-pin header connector	Six pins corresponding to the GRF-250 communication cable pins. Pin 1 is labeled on the board.
Board 2	Six-way serial interface connector	Ideal for use on the telemetry <i>telem</i> port of the Pixhawk.
Board 3	Four-way I ² C interface connector	Use an I ² C cable to connect the board to the I ² C port of the Pixhawk. Twin connections allow a daisy chain connection to other sensors.
Board 4	Servo motor interface connector	The host controller can power, communicate with, and control both the servo motor and the GRF-250 through this board, using serial communication.



5 Getting started

LightWare Studio is a free application (available for Windows, macOS, and Linux) and is the gateway to configuring your microLiDAR® rangefinder and visualizing your data. This software empowers you to customize settings, fine-tune rangefinder parameters, and easily analyze data. It also facilitates firmware upgrades and in-field diagnostics and support.

Detailed step-by-step videos are available on LightWare's YouTube channel:

<https://www.youtube.com/@LightWareLiDAR/videos>

Follow these easy steps to get going with your LightWare microLiDAR®:

1. Download and install the version of LightWare Studio compatible with your operating system from the LightWare **resource center** via <https://lightwarelidar.com/>. You can safely install over an existing version of LightWare Studio if you are upgrading.

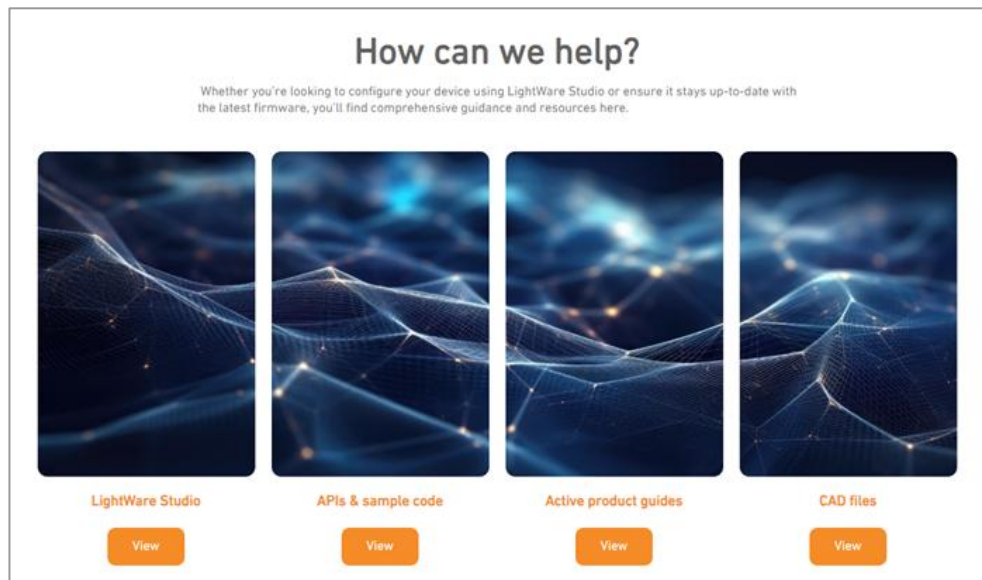

Figure 7: LightWare Studio website download page

2. Once the installation is complete, the *Welcome to LightWare Studio* page will open, prompting you to attach a device to your computer.
3. Connect your LRF to a USB Type-C cable and then connect the cable to your computer. (To disconnect, simply pull the USB cable out of the computer's port.)





Figure 8: GRF-250 connection to the USB port

Caution: To avoid the risk of shorting the high voltage lines on the LRF circuit board, connect the USB cable to the sensor first before connecting it to the computer.

4. Upon connecting the LRF for the first time, Windows users may experience a brief delay as the operating system installs the necessary generic communication driver. Please allow the installation process to complete.
5. LightWare Studio will automatically detect the LRF upon successful connection, displaying the device name in the home page. The red power LEDs on the back of the LRF will light up. Click on the device name to open the device page.



Figure 9: LightWare Studio device connection page



- The device page will display the product details, including the current firmware revision.

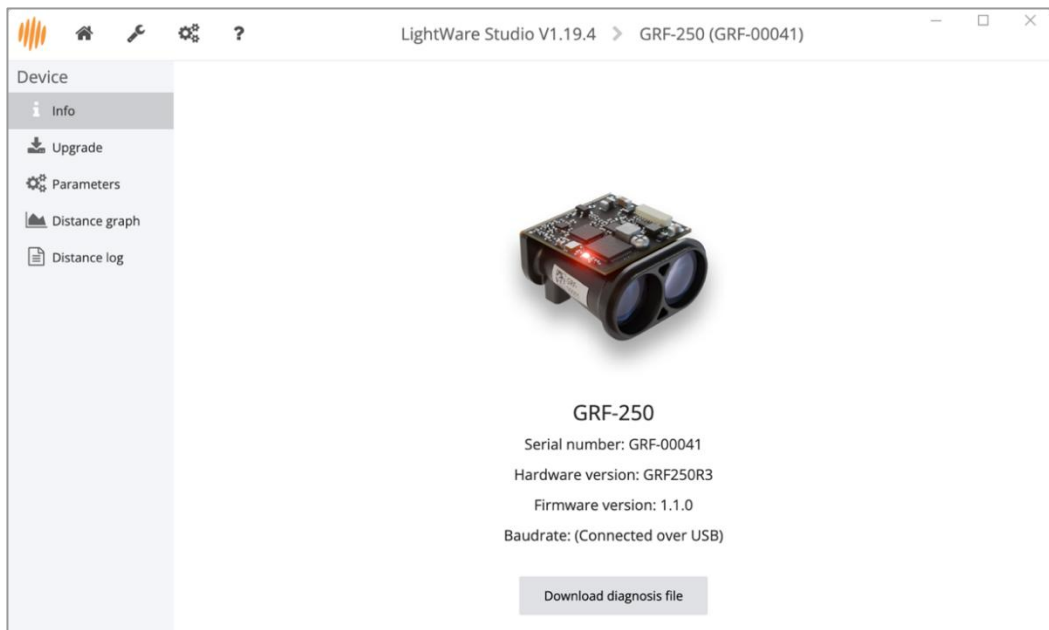

Figure 10: LightWare Studio device information page

Caution: Always keep your LightWare LRF's software up to date

- Select the *Distance graph* tool from the left menu to access real-time measurements from the sensor. Point the sensor at different obstacles to observe instant changes in distance, providing valuable insights into the sensor's live functionality.

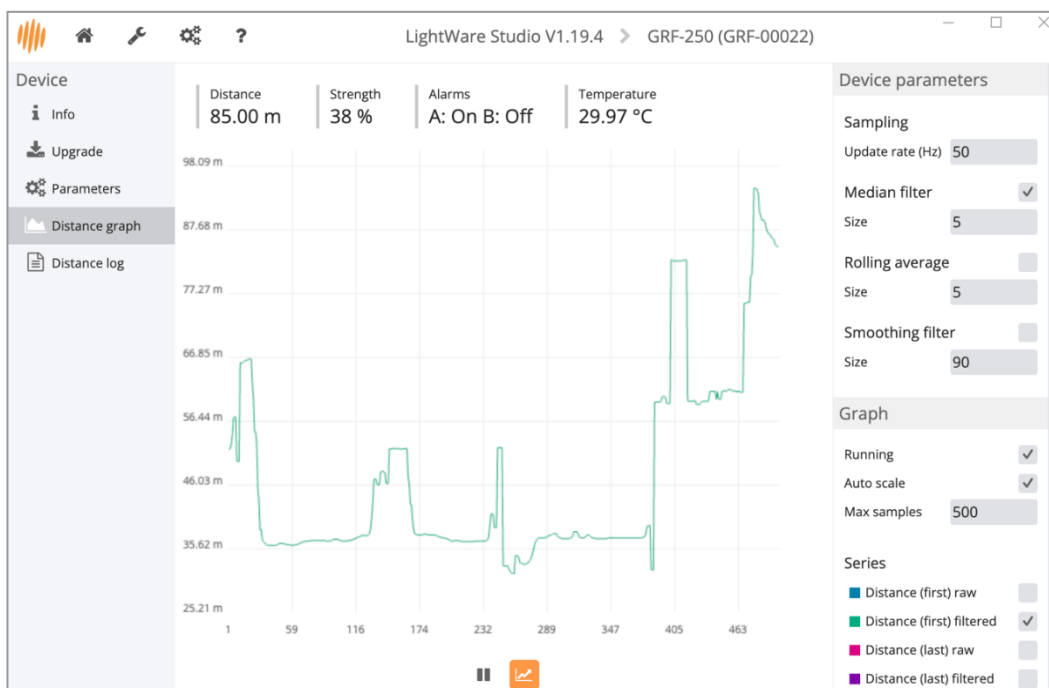

Figure 11: LightWare Studio distance graph page showing measurements



- On this page, you can control specific device parameters, which are also accessible from the dedicated parameters page. (Please refer to the section below for a more comprehensive understanding of these parameters.)



Figure 12: LightWare Studio GRF-250 parameters page

- Navigate to the *Distance log* tool from the left panel. This tool streams live distance data in meters as it is scanned by the sensor. Toggle the parameters on the left to stop or start the streaming, add line numbers or time stamps, or switch on different data types.
- Data can be downloaded and saved using the *save* icon above the data.

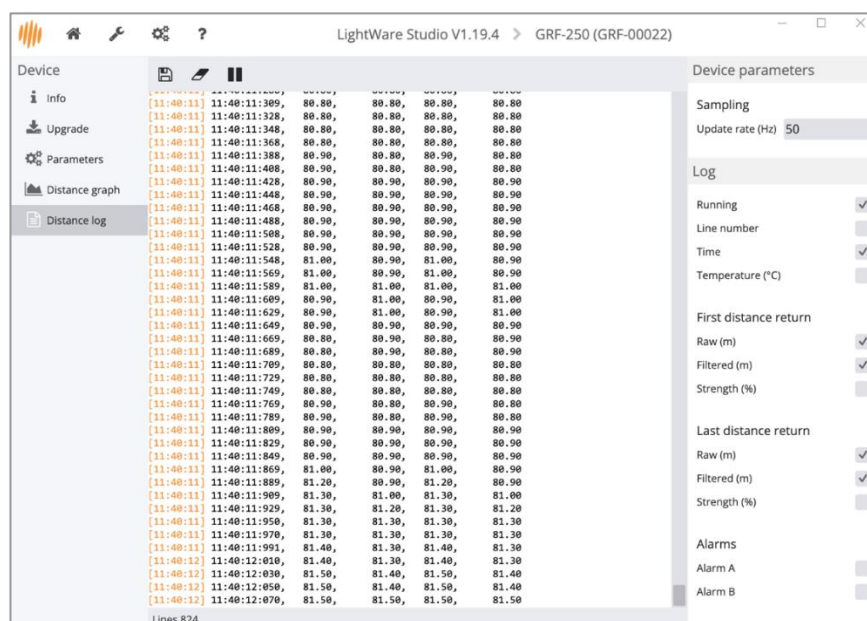

Figure 13: LightWare Studio distance log page showing measurements



6 Parameters, filters, settings and tools

6.1 Setting the device parameters

Your LightWare LRF can be configured via LightWare Studio or from a host controller through the serial or I²C communication interfaces.

1. In the left panel, click on *Parameters* to open the detailed parameters page.
2. The scroll-down list of adjustable parameters will be displayed, with explanatory notes and dropdown options.

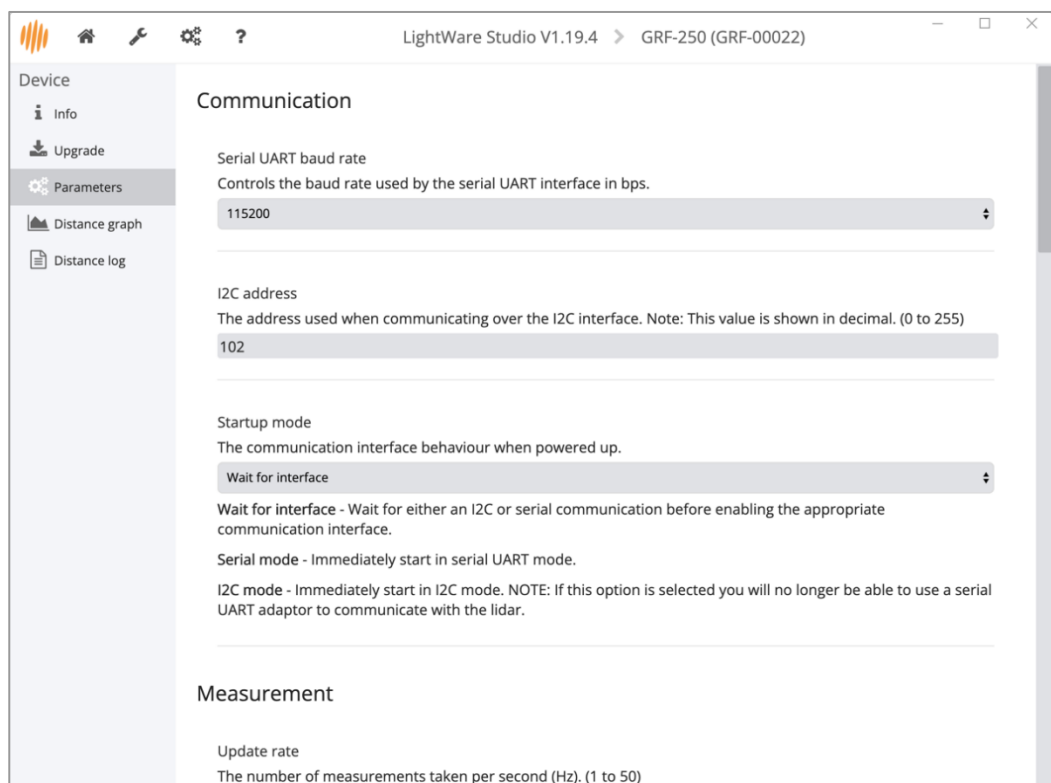

Figure 14: LightWare Studio detailed parameters page

3. Set your device parameters according to your requirements. Refer to the table below for more information.



4.

Table 4: GRF-250 adjustable parameters

Parameter	Explanation	Options
Communication		
Serial UART baud rate	The baud rate used by the serial UART interface in kbps.	From 9600 to 921,600
I2C address	The address used when communicating over the I ² C interface. Note that this value is in decimal.	From 0 to 127
Startup mode	Wait for interface — Wait for an I ² C or serial [UART] communication before enabling the appropriate interface. Serial mode — Immediately start in serial UART mode. I2C mode — Immediately start in I ² C mode. Note: If this option is selected, you can no longer use a serial UART adapter to communicate with the LiDAR.	Wait for interface; Serial mode; or I ² C mode.
Measurement:		
Update rate	The number of measurements taken per second.	From 1 Hz to 50 Hz
Zero distance offset	An offset applied to the measured distance value in meters.	From -10 meters to +10 meters
Lost signal threshold	The number of failed measurements before a loss of signal is reported.	Whole numbers from 1 to 250
Auto exposure	Improves performance at shorter distances	Select or de-select the checkbox
Blanking distance	Any measurement distances (in meters) lower than this value will be reported as lost signal.	Whole numbers from 1 to 20
Filtering:		
Median filter enabled	Used to disregard short unwanted measurements.	Select or de-select the checkbox
Median filter size	The response time of the median filter, in seconds.	Whole numbers from 3 to 32
Rolling average enabled	Used to average out a specified number of last-distance results.	Select or de-select the checkbox
Rolling average filter size	The number of distance results to use for the rolling average filter.	Whole numbers from 2 to 32
Smoothing filter enabled	Used to remove noise from the measurements.	Select or de-select the checkbox
Smoothing filter strength	The stronger the smoothing, the slower the response to change.	Whole numbers from 0 to 100
Alarms:		
Alarm A distance	Warn when an object is detected closer than this user-set alarm distance. (In meters, up to two decimal places.) When scanning is activated, the object must also be between the left and right alarm angles.	0 to 300
Alarm B distance	Warn when an object is detected closer than this user-set alarm distance. (In meters, up to two decimal places.) When scanning is activated, the object must also be between the left and right alarm angles.	0 to 300 meters
Alarm hysteresis	The amount by which distance reading must decrease below the alarm distance before the alarm is cleared. Used	0 to 300 meters



	to prevent alarm chatter. (In meters, up to two decimal places.)	
Extra		
LED enabled	Turns the device LED on or off.	Select or de-select the checkbox
GPIO mode	Select the output function of the GPIO port.	None; Alarm A; Alarm B
GPIO alarm confirms	The number of update rate cycles that the alarm must be active before it is indicated as such on the GPIO output pin.	0 - 1000

6.2 Filters

Median Filter

This is a non-linear filter in which each output is the median, or middle, of the readings in the filter window. It is helpful for removing outliers and signal noise. A typical application is flying over terrain where quick changes in terrain height must not affect the altitude of the UAV, such as over water. The larger the filter size, the more immune the filter is to noise. This, however, does result in a delayed response to changes in the measurement.

Rolling average filter

A rolling average filter averages a fixed number of the newest data points. This smooths out short-term fluctuations and reveals trends. Typically applied when noisy fluctuations should be ignored, but the general profile of the data should be maintained, such as for terrain following.

Smoothing filter

This filter smooths sharp changes in the data while preserving slower changes. It helps to remove noise from the data and slows the response to sudden data changes. Typically used when monitoring the distance to stationary surfaces, such as when taking level measurements and filling rates.



6.3 Settings and tools

Additional application **settings** are available by clicking on the *gears* icon in the top menu:

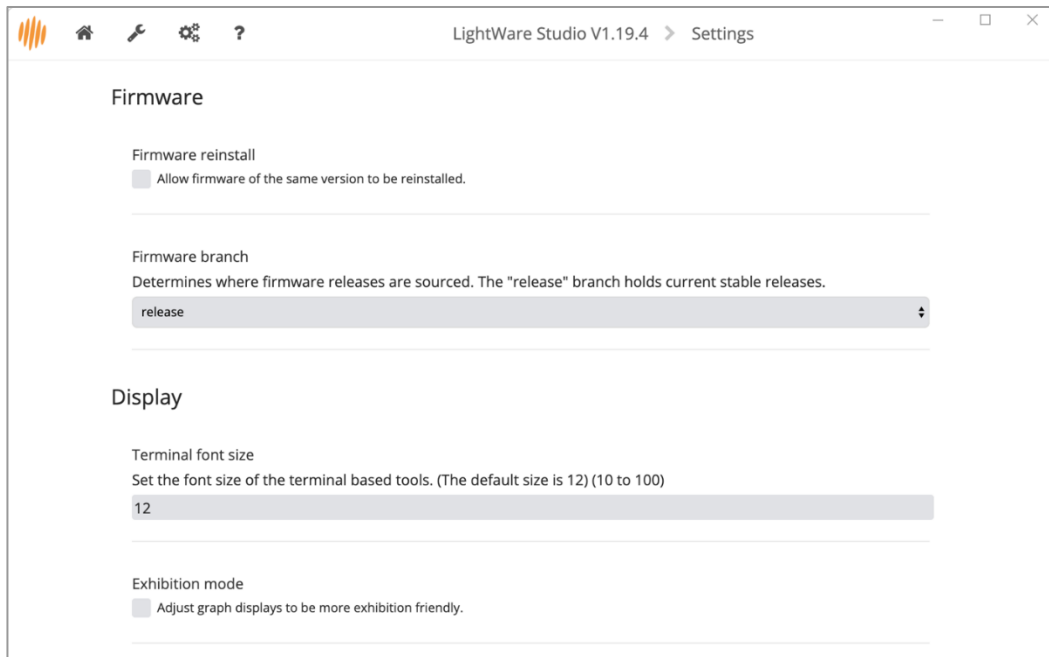

Figure 15: LightWare Studio application settings page

You can access the **specialized device tools page** by clicking on the *wrench* icon in the top menu, where you can access a traditional terminal if needed:

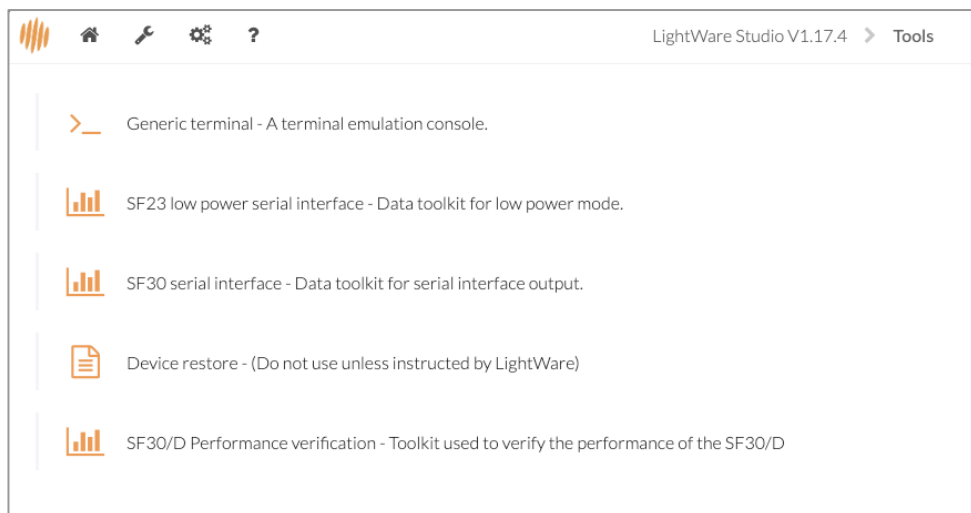

Figure 16: LightWare Studio specialized tools page



7 Installation, mounting, and cabling

7.1 Mechanical interface

For detailed CAD files, please refer to the LightWare resource center at <https://lightwarelidar.com/>.

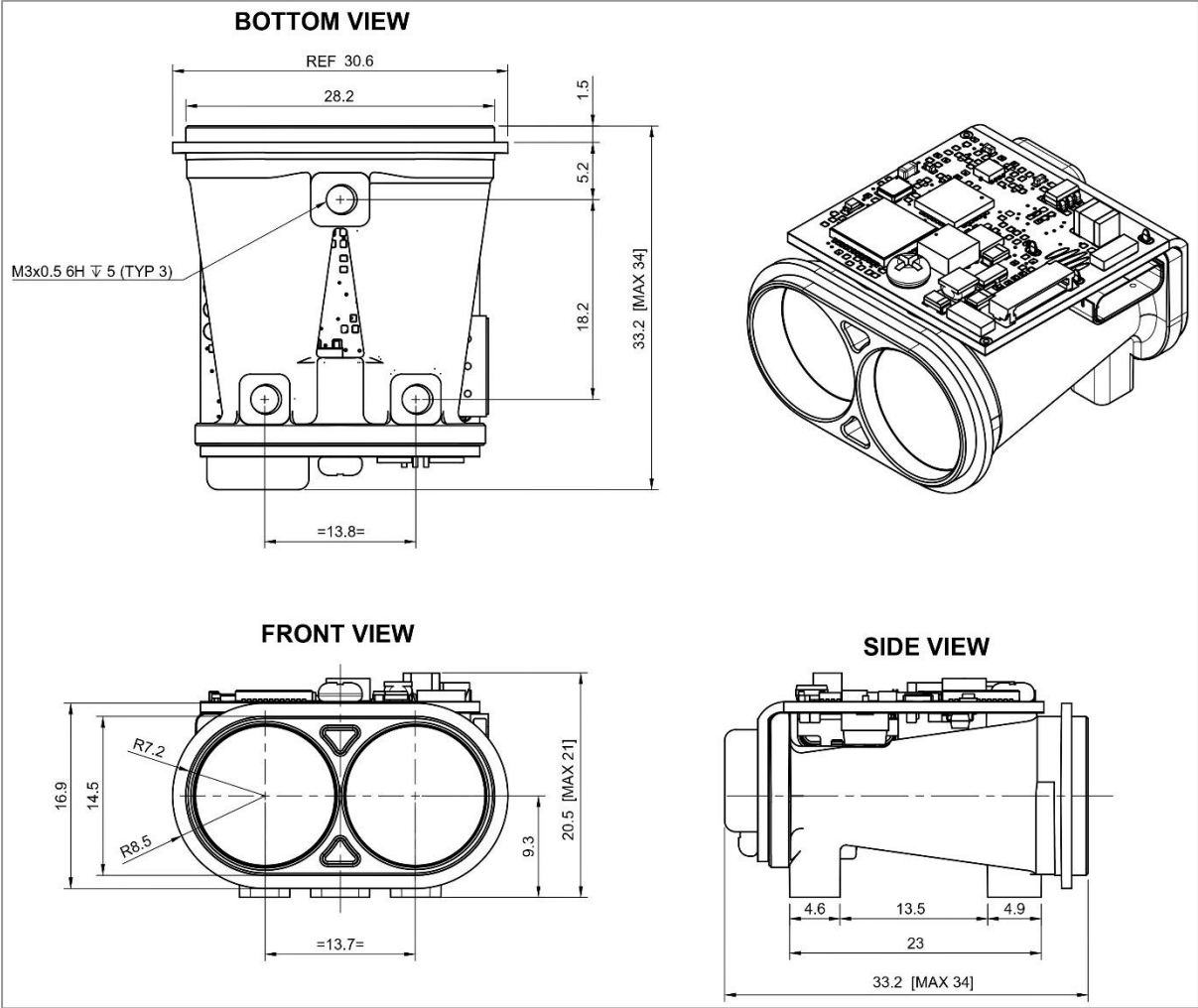

Figure 17: GRF-250 mechanical interface

Caution: Ensure that adequate ventilation or heat sinking is provided if the LRF is incorporated into a custom enclosure, as heat build-up could occur.



7.2 Mounting and alignment instructions

The GRF-250 features three mounting feet, facilitating side mounting when integrated with a gimbal system.

Take careful note of the following points when mounting the LRF:

- When choosing a position, ensure that there is **nothing in the path** of the laser beam, and **no shiny or highly reflective surfaces near the beam path**, that could result in false signals.
- Do not mount the sensor within a cavity. This can cause false readings in short-range distances (side lobes) or out-of-range conditions. Mount the sensor **directly at the surface boundary** or keep the recess conical and shallow.
- Ensure a **watertight seal** between the front flange and surface to protect the back end of the sensor.



Figure 18: An example of good integration

- To ensure proper alignment and **optimal boresight**, it is essential to fasten the unit according to the torque specification stipulated in the interface drawing.
- Ensure all three mounting feet are flush to ensure boresight specification is met.
- Make sure the sensor is securely mounted to prevent false readings or damage.
- The GRF-series is designed for installation with exposed lenses. If it is to be mounted behind glass, ensure non-reflective glass is used to prevent false readings. The glass must have good transmission at 905 nm wavelength, with an anti-reflective coating optimized for this wavelength.
- If the sensor is mounted behind non-reflective glass, the glass must be angled between 3° and 10° away from the receiver lens, toward the laser lens, as shown in the diagram below:



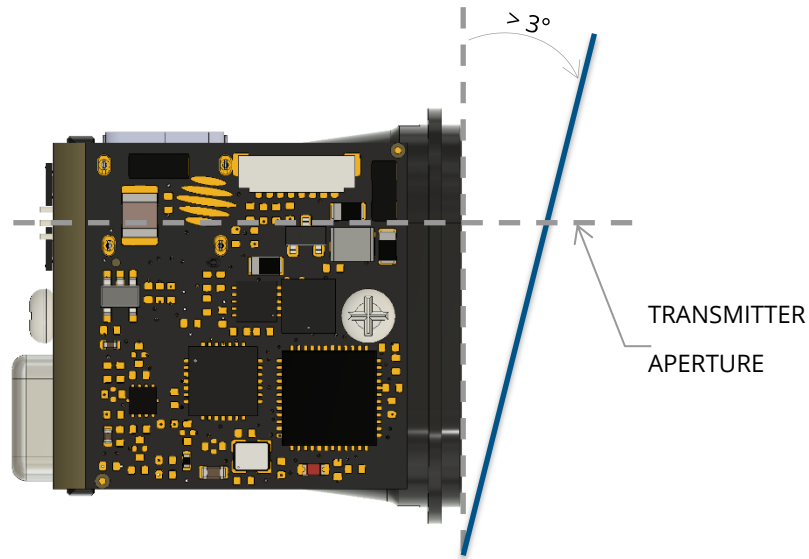

Figure 19: Behind-glass installation angle

- To avoid electromagnetic interference (EMI) affecting the sensor, ensure there is a 10 mm *no-fit zone* behind the device.
- Ensure adequate **ventilation or heat sinking** if the LRF is incorporated into a custom enclosure to prevent heat build-up.
- Secure the communication cable to prevent it from pulling on the connection port.

7.3 Orientation

The LRF requires a **clear line-of-sight** to measure distance to a target surface. It can be mounted with a **vertical or horizontal** lens orientation.



Figure 20: LRF mounting orientations



7.4 Communication and power cable

The LRF is supplied with a A08SUR08SUR32W102A communication cable. Spare cables are available from the LightWare online store: <https://lightwarelidar.com/>.

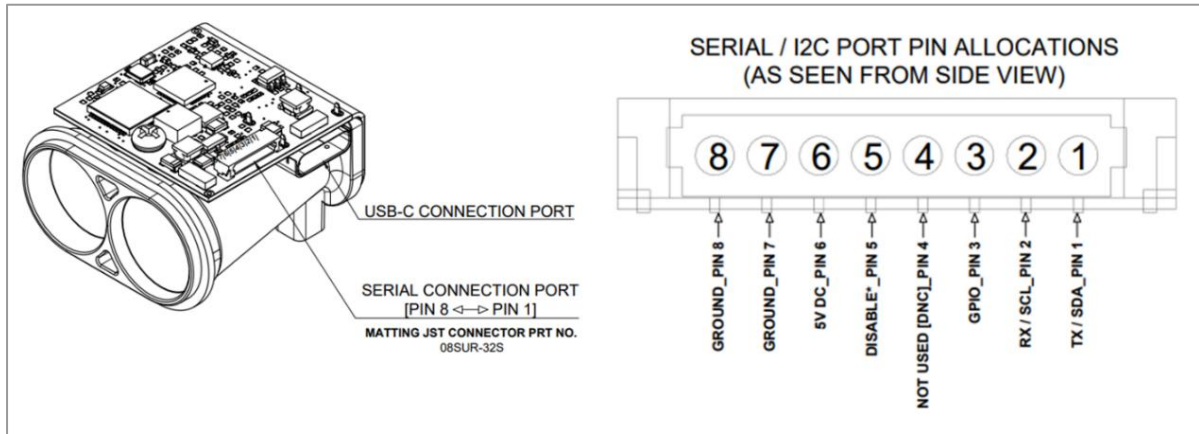

Figure 21: Communication cable pinout

Table 5: GRF-250 pinout table

Connector Pin	Serial Function	I ² C Function
1	TXD, transmit data for serial connections	SDA, serial data for I ² C connections
2	RXD, receive data for serial connections	SCL, serial clock for I ² C
3	GPIO	
4	[pin not used]	
5	Disable*	
6	VIN, +5 V power supply positive (4.5 V to 5.5 V at 120 mA typical, 250 mA max)	
7	Ground	
8	Ground	

* Leave floating for operation, connect to ground to disable.



8 Advanced features

8.1 Five distance output

If more than one target is identified within its field of view, the LRF will report up to five discrete target distances.

Both a distance output and a signal strength output are reported for each separately identified target. Signal strength serves as a metric for assessing the reliability of a reading; a reading with low signal strength may be considered an outlier and can be omitted.

Additionally, signal strength indicates the reflectivity of the object. Please refer to the command list, below in this document, for more detailed information on the outputs.

8.2 First and last pulse detection

This LightWare microLiDAR® rangefinder features *first and last pulse* processing, capturing both initial and final laser return signals in scenarios where multiple objects are within the rangefinder's line of sight. It is important to note that objects must be separated by approximately twenty meters or more for separate return signals to be recognized.

First and last pulse capability enhances performance in challenging environmental conditions like dust, rain, fog, and snow. By discerning both pulses, the GRF-250 can effectively penetrate these elements and accurately report the furthest distance as the actual target. This feature also allows the laser rangefinder to measure the distance to objects through foliage.

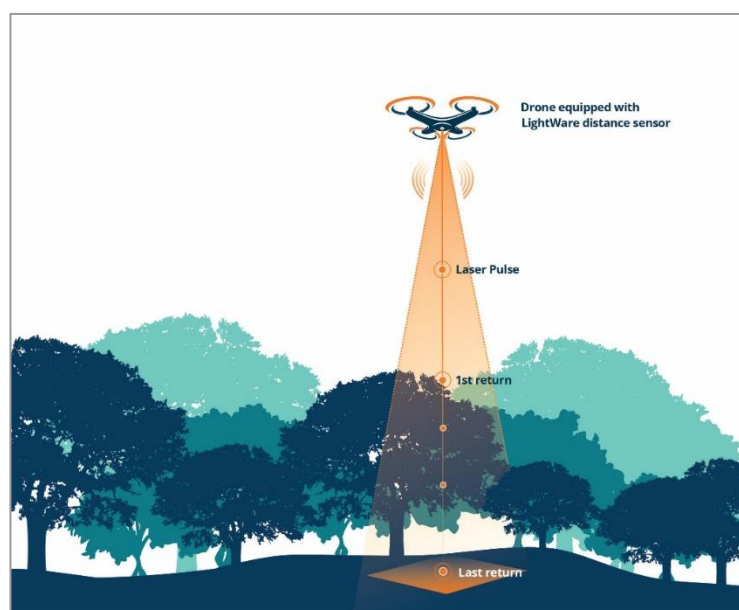

Figure 22: First and last pulse detection



A glass window in the sensor's line of sight will reflect some laser energy back toward the receiver, potentially resulting in false readings. The GRF-250's *first and last pulse* detection feature can usually mitigate this issue, depending on the type of glass used.

Although *first and last pulse* detection is helpful when the sensor needs to be positioned behind a protective window, this type of mounting is not recommended, as LightWare sensors are designed to be integrated with exposed lens elements.

8.3 Sleep mode

The GRF-250 can be put into sleep mode, which halts all laser ranging and processor functions, reducing power consumption to approximately 30% of the normal operational level. Upon waking, the processor resumes its previous state.

Sleep mode is exclusively compatible with the serial UART communication interface, as the unit wakes up with activity on the serial communication lines. This functionality is not available via USB, due to the continuous communication occurring between the USB slave and the host.

To activate sleep mode, send the value 123 to opcode 98. The unit will respond with the same value and then enter sleep mode. Any subsequent communication with the unit will wake it up to resume normal operation.

8.4 Alarms

Your LightWare GRF-250 microLiDAR® rangefinder measures and reports distances and has a dedicated alarm channel providing two separate live alarm status outputs, warning of potentially hazardous conditions.

Alarm A and Alarm B give separate warnings when the ground (or another object) is detected closer than their user-set alarm distances. Each time a distance measurement is taken, the data is analyzed internally by the sensor and the alarm statuses are updated in real time.

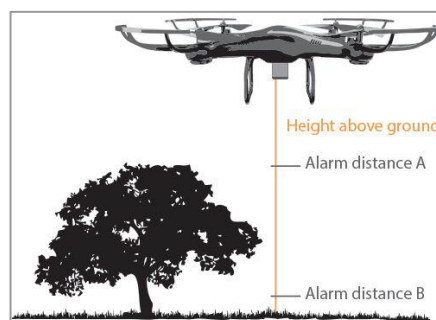

Figure 23: Alarm A and B



9 Communications interfaces

The LightWare LRF can be connected to a host controller, transmitting results and receiving commands with a **serial UART** or an **I²C communication interface**.

- The one-to-one serial UART interface allows one sensor to communicate with a single host controller.
- The configurable address of the I²C communication interface allows multiple sensors to be connected to one host controller on a common bus.

Once a sensor is connected to a host controller, the first command from the host controller will inform it which of the two communication interfaces is being used. Subsequent commands sent from the host controller to the sensor will request values, change settings, or alter the sensor's performance. The sensor will reply to a single command with a single reply, although the streaming command allows the sensor to continuously update the reply without the host resending the command. Note that streaming data is only available through the serial UART interface. The complete command list is contained in this product guide.

We suggest using LightWare's pre-built APIs wherever possible, which are available via the LightWare website resource center. If you require more control or do not find a suitable pre-built API, you can use the information below to build a compatible system. The packet-based binary protocol is compatible with higher-level APIs like C, Python, and JavaScript. Please contact LightWare for assistance with APIs or programming if required.

9.1 Serial UART interface

For serial UART communication, the sensor uses encapsulated packets to send and receive data. A packet sent **to** the sensor is a request. A correctly formatted request will always be **replied** to with a response. Streaming is available through the serial UART interface. In this case, the sensor sends request streaming packets without a direct request from the host, and they do not require a response from the host.

Requests are made using one of the sensor commands. The complete command list is contained in this product guide. Commands are flagged as either read or write. When a read request is issued, the response will contain the requested data. When a write request is issued, the contents of the response will vary depending on the command.



Default serial UART interface properties:

- Baud rate: 115200 (configurable)
- Data: 8 bit
- Parity: none
- Stop: 1 bit
- Flow control: none

9.2 I²C interface

For I²C communication, the sensor will always be the slave on the I²C interface and only transmit data when requested by the master.

Multiple sensors can be connected to an I²C bus. The I²C serial bus configurable address allows connecting multiple devices on a common bus. Default I²C interface Address: 0x66 or 102. The sensor's I²C interface SDA and SCL pins use 3.3 V logic levels with a 3.3kΩ pull-up resistors, but are also 5 V tolerant.

Requests are made using one of the sensor commands. The complete command list is contained below in this product guide. When a read request is issued the response will contain the requested data. When a write request is issued there is no response generated.

10 Commands

Your LightWare microLiDAR® rangefinder uses the packet-based binary protocol for both serial UART and I²C communication. The packet-based binary protocol is a register-based protocol that is compatible with higher-level APIs like C, Python, and JavaScript. This is protocol allows for various data streaming from a single request.

The first command sent by the host to the sensor after powerup will be used to detect whether serial UART or I²C mode is in use. The sensor will not return a response to the first command. Subsequently, for each command sent by the host controller, a single reply will be returned by the sensor.

To initialize the communication with the sensor, send the command to request the Product name. It is advisable to send the command to query the Product name twice in succession shortly after powerup. As described above the first request will not return a response, however the second request will return the product name, indicating that the sensor has



indeed initialized successfully, and a handshake has been successfully established with the sensor.

The streaming (\$) command can be used to command the sensor to continuously update the reply without waiting for the host controller to resend the command

10.1 Command structure

Both request and response **packets** are composed of the following bytes:

Table 6: Packet composition

	Header			Payload		Checksum	
Byte	start	flags low	flags high	ID	data	CRC low	CRC high

Table 7: Header Flag byte explanation

Byte	Flags high								Flags low							
Bit	15	14	13	12	11	10	9	8	7	6	5	4	3	2	1	0
	Payload length (0 to 1023)								Reserved						Write	

- The **start** byte is always 0xAA and indicates the beginning of a packet.
- The **flags** bytes form a 16-bit integer representing the packet's payload length and read/write status.
- The **payload** includes the ID byte, the data bytes, and the write bit. Its length is between 1 and 1023 bytes, inclusive depending on the command type.
- The **ID** byte indicates which command the request/response relates to.
- The **command list** is contained later in this product guide.
- The **write** bit is 1 to indicate write mode, or 0 to indicate read mode.
- The **CRC** bytes form a 16-bit/2-byte checksum value used to validate the integrity of the packet data. The LRF will not accept and process a packet if the CRC is not correctly formed. Every byte in the packet except for the CRC itself is included in the checksum calculation.



10.2 Checksum algorithm

The **checksum** algorithm is a 16-bit CRC. Below are two CRC calculation examples:

Table 8: Checksum algorithm

C/C++	JavaScript
<pre>uint16_t createCRC(uint8_t* Data, uint16_t Size) { uint16_t crc = 0; for (uint32_t i = 0; i < Size; ++i) { uint16_t code = crc >> 8; code ^= Data[i]; code ^= code >> 4; crc = crc << 8; crc ^= code; code = code << 5; crc ^= code; code = code << 7; crc ^= code; } return crc; }</pre>	<pre>function createCRC(data, size) { let crc = 0; for (let i = 0; i < size; ++i) { let code = crc >>> 8 & 0xFF; code ^= data[i] & 0xFF; code ^= code >>> 4; crc = crc << 8 & 0xFFFF; crc ^= code; code = code << 5 & 0xFFFF; crc ^= code; code = code << 7 & 0xFFFF; crc ^= code; } return crc; }</pre>



10.3 Reading bytes

It is vital to **verify the payload length and checksum** before processing it. Don't start processing at the start byte without first performing this verification. Once a packet is successfully read it can be processed based on its command ID.

If either of the following errors are received, "invalid packet length" or "checksum is invalid", please roll the incoming stream back to where the start byte was detected.

Below is the process for reading the raw serial byte stream and identifying packets:

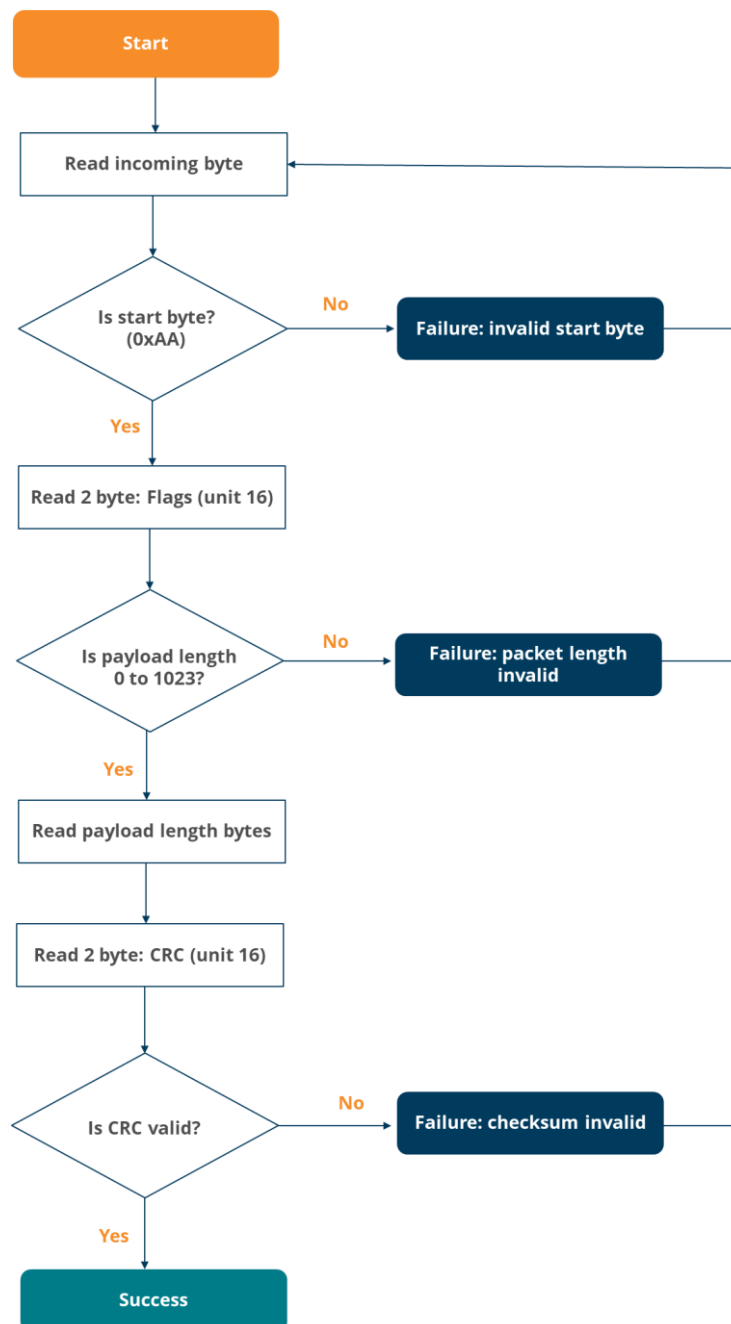

Figure 24: Process flow for reading bytes



10.4 Sending commands

Every request sent to the LRF will receive a response. The response also confirms that the request was received and processed. The timeout value and number of retries should be optimized for the specific application.

Below is the process for sending a command request and reading the response:

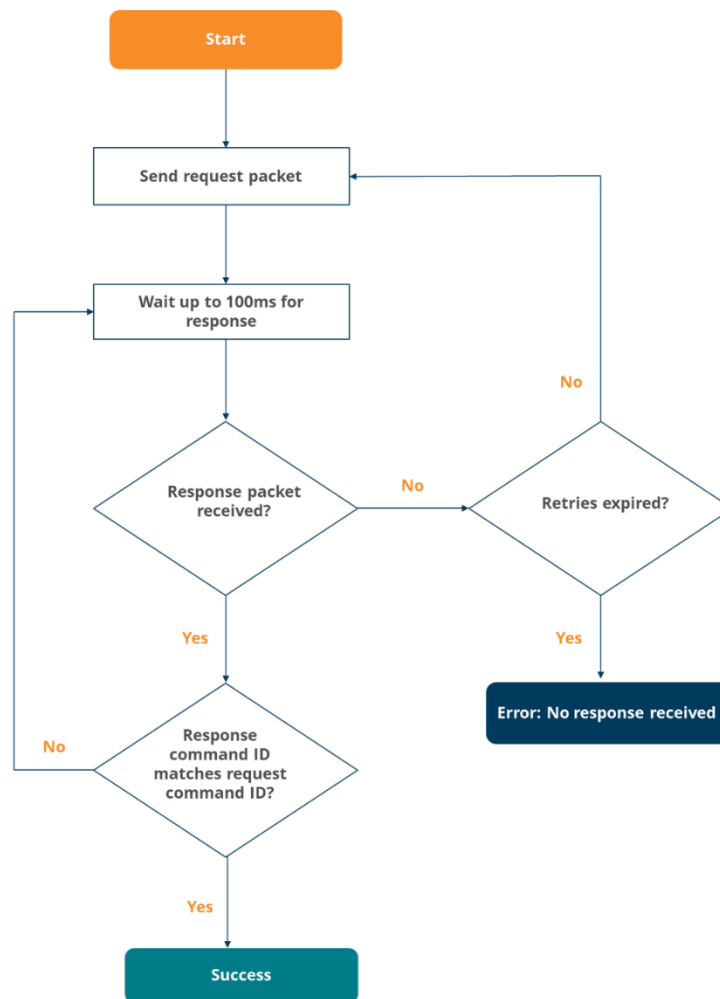

Figure 25: Process flow for sending commands

10.5 Saving

Parameters listed in the command list below, and indicated to persist across power cycles, must be saved to onboard flash once changed. To save the parameters, the Token (ID 10) must be read from the unit by sending a read command. The value received must then be sent as the data in the Save Parameters command (ID 12) to the unit.

The Token expires every time after use and consecutive save commands will require the request of a new token prior to the save commands sent.



10.6 Command list

Table 9: Command list with descriptions

ID	Name	R/W	Read bytes/ format	Write bytes/ format	Persis ts	Description																											
0	Product name	R	16	-	-	A 16-byte string indicating product model name. Always GRF250 followed by a null terminator. Use to verify the GRF-250 is connected and operational over the selected interface.																											
1	Hardware version	R	4 /uint32	-	-	The hardware revision number as a uint32.																											
2	Firmware version	R	4	-	-	The currently installed firmware version as 4 bytes. Used to identify the product for API compatibility. <table border="1" style="margin-left: 20px;"> <thead> <tr> <th>3</th> <th>2</th> <th>1</th> <th>0</th> </tr> </thead> <tbody> <tr> <td>Reserved</td> <td>Major</td> <td>Minor</td> <td>Patch</td> </tr> </tbody> </table>	3	2	1	0	Reserved	Major	Minor	Patch																			
3	2	1	0																														
Reserved	Major	Minor	Patch																														
3	Serial number	R	16	-	-	A 16-byte string (null-terminated) of the serial identifier assigned during production.																											
9	User data	RW	16	16	Yes	16 bytes of user data stored and read for any purpose.																											
10	Token	R	2 /uint16	-	-	Next usable safety token / Current safety token. Once used, it will expire, and a new token will be created.																											
12	Save parameters	W	-	2 /uint16	-	Several commands write to parameters that must be stored and persist across power cycles. This happens when the <i>save parameters</i> command is written with the appropriate safety token. The safety token prevents unintentional writes. The token expires once a successful save has completed.																											
14	Reset	W	-	2 /uint16	-	Writing the safety token to this command will restart the LRF.																											
16	Stage firmware	RW	4 / int32	130	-	<p>The first step of uploading firmware is to stage the data. Write the firmware upgrade file in 128-byte pages using the following data structure:</p> <table border="1" style="margin-left: 20px;"> <thead> <tr> <th>Offset</th> <th>Type</th> <th>Description</th> </tr> </thead> <tbody> <tr> <td>0x0</td> <td>int16</td> <td>Index of page</td> </tr> <tr> <td>0x2</td> <td>128 bytes</td> <td>Bytes of page</td> </tr> </tbody> </table> <p>When reading this command, or analyzing its response after writing a page, the packet will contain an int32 error code:</p> <table border="1" style="margin-left: 20px;"> <thead> <tr> <th>Value</th> <th>Description</th> </tr> </thead> <tbody> <tr> <td>0 to 1000</td> <td>Index of successfully written page</td> </tr> <tr> <td>-1</td> <td>Page length is invalid</td> </tr> <tr> <td>-2</td> <td>Page index is out of range</td> </tr> <tr> <td>-3</td> <td>Flash failed to erase</td> </tr> <tr> <td>-4</td> <td>Firmware file has invalid header</td> </tr> <tr> <td>-5</td> <td>Flash failed to write</td> </tr> <tr> <td>-6</td> <td>Firmware is for different device</td> </tr> <tr> <td>-7</td> <td>Firmware is for a different product</td> </tr> </tbody> </table>	Offset	Type	Description	0x0	int16	Index of page	0x2	128 bytes	Bytes of page	Value	Description	0 to 1000	Index of successfully written page	-1	Page length is invalid	-2	Page index is out of range	-3	Flash failed to erase	-4	Firmware file has invalid header	-5	Flash failed to write	-6	Firmware is for different device	-7	Firmware is for a different product
Offset	Type	Description																															
0x0	int16	Index of page																															
0x2	128 bytes	Bytes of page																															
Value	Description																																
0 to 1000	Index of successfully written page																																
-1	Page length is invalid																																
-2	Page index is out of range																																
-3	Flash failed to erase																																
-4	Firmware file has invalid header																																
-5	Flash failed to write																																
-6	Firmware is for different device																																
-7	Firmware is for a different product																																



ID	Name	R/W	Read bytes/ format	Write bytes/ format	Persis ts	Description																											
17	Commit firmware	RW	4 / int32	0	-	<p>Once the firmware data has been fully uploaded using the 16. Stage Firmware command, then this command can be written to (with 0 bytes).</p> <p>When reading this command, or analyzing its response after writing, the packet will contain an int32 error code:</p> <table border="1"> <thead> <tr> <th>Value</th> <th>Description</th> </tr> </thead> <tbody> <tr> <td>-1</td> <td>Integrity check failed</td> </tr> <tr> <td>1</td> <td>Integrity check passed and firmware committed.</td> </tr> </tbody> </table> <p>Once the firmware is committed, a reboot is required to engage the new firmware. This can be done by cycling power or by sending the 14. Reset command.</p> <p>After the unit has rebooted the firmware version should be checked to ensure the firmware is installed.</p>	Value	Description	-1	Integrity check failed	1	Integrity check passed and firmware committed.																					
Value	Description																																
-1	Integrity check failed																																
1	Integrity check passed and firmware committed.																																
27	Distance output	RW	4 /uint32	4 /uint32	No	<p>Configures the (44) distance data command data output. Each bit toggles the output of specified data.</p> <table border="1"> <thead> <tr> <th>Bit</th> <th>Output</th> </tr> </thead> <tbody> <tr> <td>0</td> <td>First return raw</td> </tr> <tr> <td>1</td> <td>First return filter</td> </tr> <tr> <td>2</td> <td>First return strength</td> </tr> <tr> <td>3</td> <td>Last return raw</td> </tr> <tr> <td>4</td> <td>Last return filter</td> </tr> <tr> <td>5</td> <td>Last return strength</td> </tr> <tr> <td>6</td> <td>Temperature</td> </tr> <tr> <td>7</td> <td>Alarm status</td> </tr> </tbody> </table>	Bit	Output	0	First return raw	1	First return filter	2	First return strength	3	Last return raw	4	Last return filter	5	Last return strength	6	Temperature	7	Alarm status									
Bit	Output																																
0	First return raw																																
1	First return filter																																
2	First return strength																																
3	Last return raw																																
4	Last return filter																																
5	Last return strength																																
6	Temperature																																
7	Alarm status																																
30	Stream	RW	4/ uint32	4 /uint32	No	<p>Serial and USB interface only. (If used on I²C, the data will not be retrievable.)</p> <p>Reading from the stream command will indicate what type of data is currently being streamed. Writing to the stream command will set the type of data to be streamed.</p> <table border="1"> <thead> <tr> <th>Value</th> <th>Streamed data</th> </tr> </thead> <tbody> <tr> <td>0</td> <td>disabled</td> </tr> <tr> <td>5</td> <td>(44) stream first and last distance data</td> </tr> <tr> <td>6</td> <td>(45) stream five distances data</td> </tr> </tbody> </table>	Value	Streamed data	0	disabled	5	(44) stream first and last distance data	6	(45) stream five distances data																			
Value	Streamed data																																
0	disabled																																
5	(44) stream first and last distance data																																
6	(45) stream five distances data																																
44	Distance data in cm	R	varies	-	-	<p>Distance data in 0.1 m resolution as measured by the GRF-250. This command can be read any time, but if (30) stream is set to 5, this command will automatically output at the measurement update rate. The data included will vary and be packed in order based on the configuration of the (27) distance output command.</p> <table border="1"> <thead> <tr> <th>Data output bit</th> <th>Description</th> <th>Size</th> </tr> </thead> <tbody> <tr> <td>0</td> <td>First return raw</td> <td>int32</td> </tr> <tr> <td>1</td> <td>First return filtered</td> <td>int32</td> </tr> <tr> <td>2</td> <td>First return strength (dB)</td> <td>int32</td> </tr> <tr> <td>3</td> <td>Last return raw</td> <td>int32</td> </tr> <tr> <td>4</td> <td>Last return filtered</td> <td>int32</td> </tr> <tr> <td>5</td> <td>Last return strength (dB)</td> <td>int32</td> </tr> <tr> <td>6</td> <td>Temperature (0.01°C)</td> <td>int32</td> </tr> <tr> <td>7</td> <td>Alarm status</td> <td>int32</td> </tr> </tbody> </table>	Data output bit	Description	Size	0	First return raw	int32	1	First return filtered	int32	2	First return strength (dB)	int32	3	Last return raw	int32	4	Last return filtered	int32	5	Last return strength (dB)	int32	6	Temperature (0.01°C)	int32	7	Alarm status	int32
Data output bit	Description	Size																															
0	First return raw	int32																															
1	First return filtered	int32																															
2	First return strength (dB)	int32																															
3	Last return raw	int32																															
4	Last return filtered	int32																															
5	Last return strength (dB)	int32																															
6	Temperature (0.01°C)	int32																															
7	Alarm status	int32																															



45	Distance data in mm	R	44	-	-	Distance data in 0.1 m resolution as measured by the GRF-250. This command can be read any time, but if (30) stream is set to 6, this command will automatically output at the measurement update rate.																								
							<table border="1"> <thead> <tr> <th>Description</th> <th>Size</th> </tr> </thead> <tbody> <tr> <td>First return distance</td> <td>int32</td> </tr> <tr> <td>First return strength (dB)</td> <td>int32</td> </tr> <tr> <td>Second return distance</td> <td>int32</td> </tr> <tr> <td>Second return strength (dB)</td> <td>int32</td> </tr> <tr> <td>Third return distance</td> <td>int32</td> </tr> <tr> <td>Third return strength (dB)</td> <td>int32</td> </tr> <tr> <td>Fourth return distance</td> <td>int32</td> </tr> <tr> <td>Fourth return strength (dB)</td> <td>int32</td> </tr> <tr> <td>Last return distance</td> <td>int32</td> </tr> <tr> <td>Last return strength (dB)</td> <td>int32</td> </tr> </tbody> </table>		Description	Size	First return distance	int32	First return strength (dB)	int32	Second return distance	int32	Second return strength (dB)	int32	Third return distance	int32	Third return strength (dB)	int32	Fourth return distance	int32	Fourth return strength (dB)	int32	Last return distance	int32	Last return strength (dB)	int32
							Description	Size																						
							First return distance	int32																						
							First return strength (dB)	int32																						
							Second return distance	int32																						
							Second return strength (dB)	int32																						
							Third return distance	int32																						
							Third return strength (dB)	int32																						
							Fourth return distance	int32																						
Fourth return strength (dB)	int32																													
Last return distance	int32																													
Last return strength (dB)	int32																													
<table border="1"> <thead> <tr> <th>Value</th> <th>Description</th> </tr> </thead> <tbody> <tr> <td>0</td> <td>Disabled</td> </tr> <tr> <td>1</td> <td>Enabled</td> </tr> </tbody> </table>		Value	Description	0	Disabled	1	Enabled																							
Value	Description																													
0	Disabled																													
1	Enabled																													
<table border="1"> <thead> <tr> <th>Value</th> <th>Description</th> </tr> </thead> <tbody> <tr> <td>0</td> <td>Disabled</td> </tr> <tr> <td>1</td> <td>Enabled</td> </tr> </tbody> </table>		Value	Description	0	Disabled	1	Enabled																							
Value	Description																													
0	Disabled																													
1	Enabled																													
<table border="1"> <thead> <tr> <th>Byte</th> <th>Description</th> </tr> </thead> <tbody> <tr> <td>0</td> <td>Alarm A</td> </tr> <tr> <td>1</td> <td>Alarm B</td> </tr> <tr> <td>2</td> <td>Reserved</td> </tr> <tr> <td>3</td> <td>Reserved</td> </tr> </tbody> </table>		Byte	Description	0	Alarm A	1	Alarm B	2	Reserved	3	Reserved																			
Byte	Description																													
0	Alarm A																													
1	Alarm B																													
2	Reserved																													
3	Reserved																													
<table border="1"> <thead> <tr> <th>Value</th> <th>Description</th> </tr> </thead> <tbody> <tr> <td>0</td> <td>First return</td> </tr> <tr> <td>1</td> <td>Last return</td> </tr> </tbody> </table>		Value	Description	0	First return	1	Last return																							
Value	Description																													
0	First return																													
1	Last return																													
<table border="1"> <thead> <tr> <th>Value</th> <th>Description</th> </tr> </thead> <tbody> <tr> <td>0</td> <td>First return</td> </tr> <tr> <td>1</td> <td>Last return</td> </tr> </tbody> </table>		Value	Description	0	First return	1	Last return																							
Value	Description																													
0	First return																													
1	Last return																													
<table border="1"> <thead> <tr> <th>Value</th> <th>Description</th> </tr> </thead> <tbody> <tr> <td>0</td> <td>First return</td> </tr> <tr> <td>1</td> <td>Last return</td> </tr> </tbody> </table>		Value	Description	0	First return	1	Last return																							
Value	Description																													
0	First return																													
1	Last return																													
<table border="1"> <thead> <tr> <th>Value</th> <th>Description</th> </tr> </thead> <tbody> <tr> <td>0</td> <td>First return</td> </tr> <tr> <td>1</td> <td>Last return</td> </tr> </tbody> </table>		Value	Description	0	First return	1	Last return																							
Value	Description																													
0	First return																													
1	Last return																													
50	Laser firing	RW	1 /uint8	1 /uint8	No	Reading this command will indicate the current laser firing state. Writing to this command will enable or disable laser firing.																								
55	Temperature	R	4 /uint32	-	-	Reading this command will return the measured temperature in 0.01 of a degree.																								
70	Auto exposure	RW	1 /uint8	1 /uint8	Yes	Reading this command will indicate the current auto exposure state. Writing to this command will enable or disable auto exposure.																								
74	Update rate	RW	4 /uint32	4 /uint32	Yes	Controls the data sampling update rate of the GRF-250, in samples per second or hertz. Reading this command will return the current update rate in Hz. Writing this command will set the update rate in Hz. Adjustable from 1 Hz to 50 Hz in 1 Hz increments.																								
76	Alarm status	R	4 /uint32	-	-	The feedback gives the status of the alarms.																								
77	Return mode	RW	1 /uint8	1 /uint8	Yes	Selects first or last return to be used in the alarm outputs.																								
78	Lost signal counter	RW	4 /int32	4 /int32	Yes	Sets the number of lost signal returns before a lost signal indication is output on the distance value. The distance output lost signal indication -10.																								
79	Alarm A distance	RW	4 /int32_t	4 /int32_t	Yes	Sets the Alarm A trigger distance. Any distance measured shorter than the set distance will activate this alarm and indicate a 1 on the status. The alarms trigger distance is set in 0.1 m resolution. Alarm A will reset when the distance returns to beyond the set distance plus the hysteresis setting.																								



80	Alarm B distance	RW	4 /int32_t	4 /int32_t	Yes	Sets the Alarm B trigger distance. Any distance measured shorter than the set distance will activate this alarm and indicate a 1 on the status. The alarms trigger distance is set in 0.1 m resolution. Alarm B will reset when the distance returns to beyond the set distance plus the hysteresis setting.																		
81	Alarm hysteresis	RW	4 /int32_t	4 /int32_t	Yes	The hysteresis distance is set in 0.1 m resolution, to prevent the alarm from toggling because of measurement noise. For the alarms to reset, the measured distance must exceed the setpoint plus the hysteresis value.																		
83	GPIO mode	RW	1 /uint8	1 /uint8	Yes	Changes the output mode of the alarm pin on the external connector. <table border="1" data-bbox="762 539 1281 741"> <thead> <tr> <th>Value</th> <th>Description</th> </tr> </thead> <tbody> <tr> <td>0</td> <td>No output, default state 0 V on pin</td> </tr> <tr> <td>1</td> <td>Alarm A output, with active alarm indicated by a high output of 3.3 V</td> </tr> <tr> <td>2</td> <td>Alarm B output, with active alarm indicated by a high output of 3.3 V</td> </tr> </tbody> </table>	Value	Description	0	No output, default state 0 V on pin	1	Alarm A output, with active alarm indicated by a high output of 3.3 V	2	Alarm B output, with active alarm indicated by a high output of 3.3 V										
Value	Description																							
0	No output, default state 0 V on pin																							
1	Alarm A output, with active alarm indicated by a high output of 3.3 V																							
2	Alarm B output, with active alarm indicated by a high output of 3.3 V																							
84	GPIO alarm confirm count	RW	4 /int32_t	4 /int32_t	Yes	Sets the number of update rate cycles that the measured distance must be below the set alarm distance before the output pin indicates an alarm condition. When the alarm condition resets, the pin state will immediately change to indicate this.																		
86	Median filter enable	RW	1 /uint8	1 /uint8	Yes	Reading this command will return the status of the median filter. Writing this command will set the status of the median filter. <table border="1" data-bbox="762 1025 1145 1133"> <thead> <tr> <th>Value</th> <th>Description</th> </tr> </thead> <tbody> <tr> <td>0</td> <td>Disabled</td> </tr> <tr> <td>1</td> <td>Enabled</td> </tr> </tbody> </table>	Value	Description	0	Disabled	1	Enabled												
Value	Description																							
0	Disabled																							
1	Enabled																							
87	Median filter size	RW	4 /int32	4 /int32	Yes	Reading this command will return the size of the median filter. Writing this command will set the size of the median filter. The valid range is 3 to 32.																		
88	Smoothing filter enable	RW	1 /uint8	1 /uint8	Yes	Reading this command will return the status of the smoothing filter. Writing this command will set the status of the smoothing filter. <table border="1" data-bbox="762 1301 1145 1408"> <thead> <tr> <th>Value</th> <th>Description</th> </tr> </thead> <tbody> <tr> <td>0</td> <td>Disabled</td> </tr> <tr> <td>1</td> <td>Enabled</td> </tr> </tbody> </table>	Value	Description	0	Disabled	1	Enabled												
Value	Description																							
0	Disabled																							
1	Enabled																							
89	Smoothing factor	RW	4 /uint32	4 /uint32	Yes	Reading this command will return the strength of the smoothing filter. Writing this command will set the strength of the smoothing filter. The valid range is 0 to 100.																		
91	Baud rate	RW	1 /uint8	1 /uint8	Yes	The serial baud rate used by the serial interface. This parameter only takes effect when the serial interface is first enabled after power-up or restart. Reading this command will return the baud rate. Writing to this command will set the baud rate. <table border="1" data-bbox="762 1659 1145 1989"> <thead> <tr> <th>Value</th> <th>Baud rate (bps)</th> </tr> </thead> <tbody> <tr> <td>0</td> <td>9600</td> </tr> <tr> <td>1</td> <td>19200</td> </tr> <tr> <td>2</td> <td>38400</td> </tr> <tr> <td>3</td> <td>57600</td> </tr> <tr> <td>4</td> <td>115200</td> </tr> <tr> <td>5</td> <td>230400</td> </tr> <tr> <td>6</td> <td>460800</td> </tr> <tr> <td>7</td> <td>921600</td> </tr> </tbody> </table>	Value	Baud rate (bps)	0	9600	1	19200	2	38400	3	57600	4	115200	5	230400	6	460800	7	921600
Value	Baud rate (bps)																							
0	9600																							
1	19200																							
2	38400																							
3	57600																							
4	115200																							
5	230400																							
6	460800																							
7	921600																							



92	I2C address	RW	1 /uint8	1 /uint8	Yes	The I²C address value is in decimal. Reading this command will return the I ² C address. Writing this command will set the I ² C address.						
93	Rolling average enable	RW	1 /uint8	1 /uint8	Yes	Reading this command will return the status of the rolling average filter. Writing this command will set the status of the rolling average filter. <table border="1" data-bbox="762 353 1145 465"> <thead> <tr> <th>Value</th> <th>Description</th> </tr> </thead> <tbody> <tr> <td>0</td> <td>Disabled</td> </tr> <tr> <td>1</td> <td>Enabled</td> </tr> </tbody> </table>	Value	Description	0	Disabled	1	Enabled
Value	Description											
0	Disabled											
1	Enabled											
94	Rolling average size	RW	4 /uint32	4 /uint32	Yes	Reading this command will return the size of the rolling average filter. Writing this command will set the size of the rolling average filter. The valid range is 2 to 32.						
98	Sleep Command	W	-	1 /uint8	No	Writing the value 123 to this command will switch the unit state to sleep mode. This mode is only available in serial UART communication mode. The unit is then awakened by any activity on the Serial UART communication lines. After waking up, the unit will resume the state prior to sleep and will therefore continue lasing and resume any stream output that was active.						
110	LED State	RW	1 /uint8	1 /uint8	Yes	This command will enable or disable the red LED on the unit board. The LED is an indication that the unit is active, but in light-critical conditions the LED can be switched off by the user and the state saved to ensure that it will stay off after power cycles.						
114	Zero offset	RW	4 /int32	4 /int32	Yes	Changing this offset value will change the zero-distance position for the output, written and read in 0.1 m resolution.						



11 Firmware updates

Occasionally, LightWare will release new firmware for your LRF, to address bug fixes or introduce additional features. All registered customers will receive an email notification when new firmware is released for their LightWare sensor.

Caution: LightWare strongly advises that all LightWare sensors are kept up to date with their latest firmware revision.

You can access these updates directly through LightWare Studio as follows:

1. Select *Upgrade* from the left panel to check whether your LRF is equipped with the latest firmware.

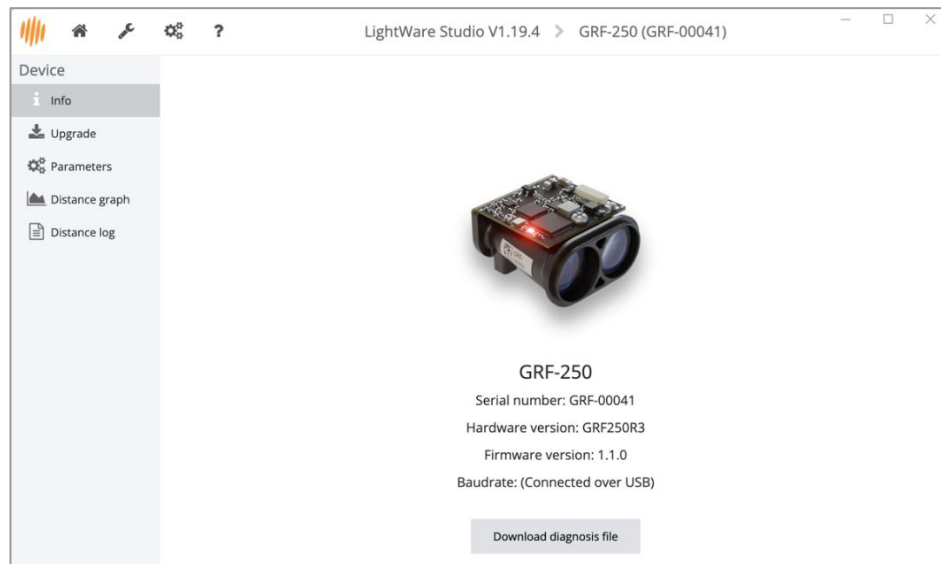

Figure 26: LightWare Studio device information page

2. The page will display the firmware version currently installed on the sensor and indicate whether any recent upgrades are available for download.
3. If you need to upgrade, click the *Install* button, and follow the instructions.

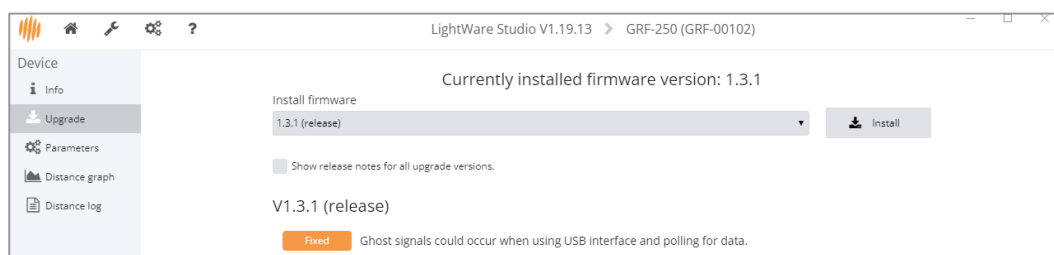

Figure 27: LightWare Studio firmware upgrade page



- The page will display the currently installed firmware version on the sensor, and it will indicate whether any recent upgrades are available for download.
- If you need to upgrade, click the *Install* button, followed by OK to confirm.

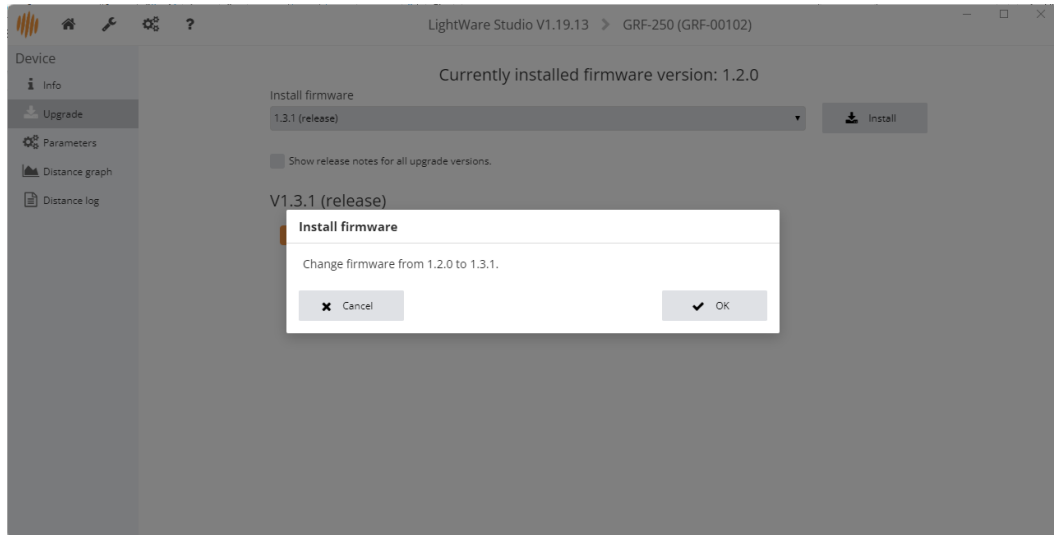

Figure 28: Confirmation of firmware upgrade

- The firmware will be installed to your device, and the device will automatically reboot.



12 Troubleshooting

Table 10: GRF-250 troubleshooting

Problem	Solution
1. Sensor outputs a short distance reading or distorted distance reading	<ul style="list-style-type: none"> The sensor is receiving a signal caused by scattered light from a close-by object in the vicinity of the beam, such as a desk surface, landing gear, pole, or highly reflective object. Relocate your sensor or the object and test again. If the sensor is placed behind protective glass, the glass must be angled between 3° and 10° away from the receiver lens, toward the laser lens, as shown earlier in this product guide.
2. Sensor outputs -1	<ul style="list-style-type: none"> The GRF-250 is designed to operate between 0.2 m and 250 m /0.6 ft and 820.2 ft. Measurements below 0.2 m or above 250 m will return an out-of-range value of -1.
3. Sensor is not communicating with the serial UART controller at all.	<ul style="list-style-type: none"> Ensure that the sensor's baud rate is compatible with the controller. Ensure that the sensor's TX and RX lines are connected to the controller's RX and TX lines, respectively. If using ArduPilot or PX4, ensure that the correct parameters for sensor integration have been set. * Ensure that the sensor supply voltage is within the specified range and is not dropping below the specified minimum level. If using a separate power supply, ensure a common ground.
4. Sensor is not communicating with the I ² C controller at all.	<ul style="list-style-type: none"> Ensure that the sensor SDA and SCL lines are connected to the controller SDA and SCL lines, respectively. If using ArduPilot or PX4, ensure that the correct parameters for sensor integration have been set. * Ensure that the sensor supply voltage is within the specified range and is not dropping below the specified minimum level. If using a separate power supply, ensure a common ground.
5. Sensor stops communicating during flight	<ul style="list-style-type: none"> Check the power supply to the sensor. Ensure all cable connections are properly seated and secured.
6. Readings are erratic or changing too fast	<ul style="list-style-type: none"> Check the update rate and ensure it is suitable for the application. Consider using the built-in filters to remove background noise. Investigate possible sources of electromagnetic interference (EMI).
7. Five distance output displays only a single reading	<ul style="list-style-type: none"> Only one reading in field of view of sensor. Please refer to the advanced features section of this user guide for more information on five distance output.
8. The sensor is running hot	<ul style="list-style-type: none"> Ensure adequate ventilation and heat sinking to prevent heat build-up.

* Coming soon

For issues not covered above, refer to the FAQs in the LightWare website resource center or contact LightWare's dedicated technical support team for assistance with remote testing of your LightWare sensor.



13 Repair and maintenance

13.1 Maintenance and calibration

The LightWare laser rangefinder contains no moving parts, and **no regular maintenance** is required. The sensor **does not need regular calibration** and will remain true to specification throughout its lifespan if used as directed.

13.2 Cleaning

If the LightWare LRF lenses collect dust, use a clean, soft cloth or air compressor to remove it. The lenses are coated with an anti-reflective, non-scratch coating. Only appropriate lens cleaning materials should be used to avoid scratching the LRF's lens or damaging the coating. Keep the device free from moisture in accordance with its IP rating.

13.3 Electrical safety

- Check all electrical connections are isolated and that there are no exposed wires.
- Ensure the power supplied to the device does not exceed the maximum rated voltages specified in the technical specifications section.
- Keep the device free from moisture in accordance with the IP rating.



13.4 Service and repairs

If you experience any problems with your LRF, please contact the LightWare technical support desk for in-field diagnostics before sending the unit to LightWare. During in-field support, you may be requested to supply the device's diagnostics file, which can be downloaded from LightWare Studio from the device *info* page.

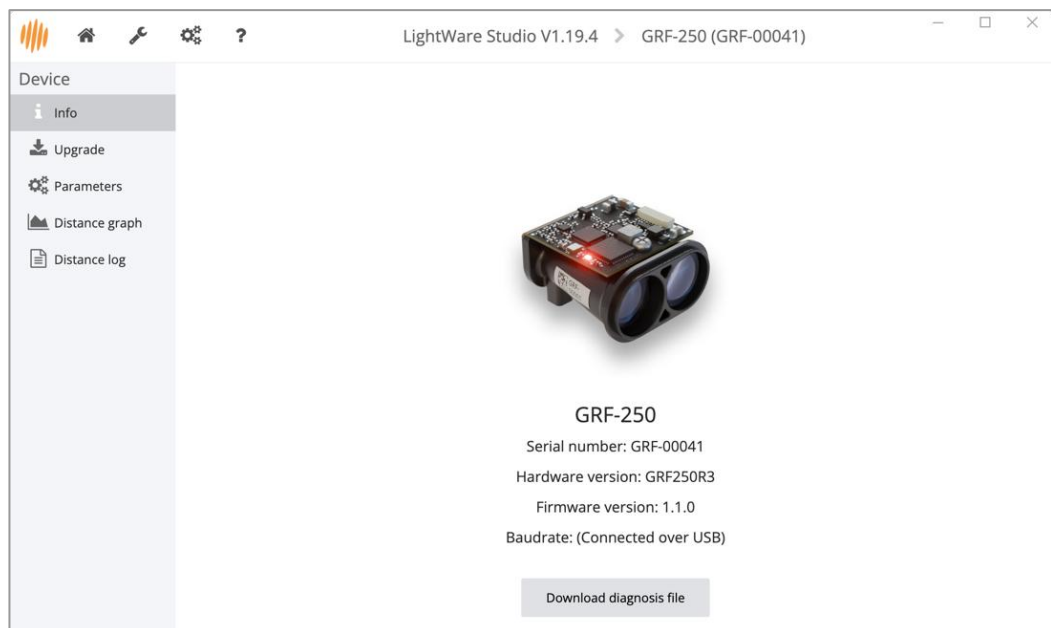

Figure 29: LightWare Studio device information page

If the unit needs to be returned to LightWare for repairs, LightWare support will assist you with the Return Merchandise Authorization (RMA) procedure.



14 End-of-life safe disposal

At LightWare, we are committed to protecting the environment and ensuring that our products have minimal impact on the planet at the end of their lifecycle. As your device reaches the end of its operational life, we encourage you to dispose of it in a responsible and environmentally friendly manner.

Please do not dispose of LightWare sensors with general household or commercial waste.

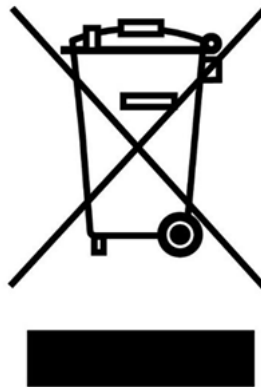

Figure 30: End-of-life disposal

LightWare sensors consist of ABS and other plastics, acrylic, and glass components, which are widely recyclable. The electronic PC board assembly should be disposed of through a reputable electronic waste recycler in your area. Alternatively, return your device to LightWare for safe disposal.



15 Document revision history

Table 11: Revision history

Revision	Date	Comments
Rev 4	2025/01/10	Updated the minimum range, text updates.
Rev 3	2024/09/06	Minor changes to Command list with added detail, and communication section 9 for improved flow.
Rev 2	2024/08/27	New document template, finalization of all specifications, added figures to getting started section. Copy Enhancement for better clarity and ease of understanding by the user and all tables numbered. FDA Accession number added. Communication cable updated to latest A08SUR08SUR32W102A.
Rev 1	2024/08/02	Adding figures in Getting Started section. Added figure for behind glass installation angle. Updated Communication cable pinout figure.
Rev 0	2024/07/29	First edition

