

Artificial intelligence enabler, high performance 8x8 multizone Time-of-Flight (ToF) sensor

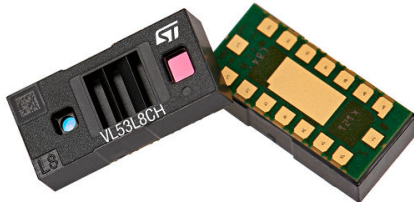

Product status link

[VL53L8CH](#)

Features

- Compact and normalized histogram (CNH) data output for AI
 - Multizone data output up to 64 separate zones
 - Histogram output with signal count for each bin
 - Histogram size programmable up to 128 bins
 - Minimum bin width down to 37 mm
 - Maximum frequency up to 30 Hz through I²C or SPI
 - Ambient IR light level reported for each zone
 - All Time-of-Flight (ToF) processed data (distance, signal amplitude, reflectance etc.) are available, in addition to CNH
- Highly configurable CNH in order to meet user expectations
 - 64 zones with 18 bins at 15 Hz
 - 32 zones with 36 bins at 15 Hz
 - 16 zones with 48 bins at 25 Hz
- Wide ToF sensor with 65° field of view (FoV)
 - 45° x 45° square FoV (65° diagonal)
 - Autonomous low-power mode with interrupt programmable thresholds to wake up the host
 - Up to 400 cm ranging
 - Motion indicator for each zone to detect if targets have moved and how they have moved
- Fully integrated miniature module
 - Emitter: 940 nm invisible-light vertical-cavity surface-emitting laser (VCSEL)
 - Diffractive optical elements (DOE) on both transmitter and receiver enabling square FoV
 - Receiving array of single photon avalanche diodes (SPADs)
 - Low-power microcontroller running firmware
 - Size: 6.4 x 3.0 x 1.75 mm
- Easy integration
 - Single reflowable component
 - Requires 1.8 V core supply and 3.3 V AVDD supply
 - Optional 1.2 V or 1.8 V IOVDD interface voltage levels
 - I²C (up to 1 MHz) or SPI (up to 3 MHz) interface
 - Compatible with a wide range of cover glass materials
 - Driver compatible with VL53L7CH
 - Pin-to-pin compatible with VL53L8CX

Application

- AI applications requiring multizone raw data
- Cup rim detection for coffee machines and beverage dispensers
- Floor sensing for robotics and vacuum cleaners
- Gesture motion and hand posture recognition
- People counting for smart buildings and smart homes

Description

The VL53L8CH is the perfect Time-of-Flight sensor enabling AI applications, with enhanced performance under ambient light with a wide 65° diagonal FoV. The compact and normalized histogram (CNH) innovative data output is specially designed for artificial intelligence (AI) applications requiring multizone raw data from a high performance multizone ToF sensor.

The IR signal measured in each zone is sent as raw data to the host through each bin of the histogram. Highly configurable, the user can program the resolution of the VL53L8CH up to 64 zones (8x8 zones), modify the histogram resolution up to 128 bins, and define the bin width. All this CNH data is transmitted to the host through I²C or SPI, up to 30 Hz, in addition to the standard processed data of the ToF sensor (ranging distance, signal level, reflectance etc.).

The CNH data transform STMicroelectronics' Time-of-Flight ranging sensor into a versatile optical sensor, which can enable endless AI-based applications. This CNH raw data sent to the host, on top of the standard ranging data, opens the door to many new applications beyond simple distance measurements. From solid material (carpet, wood, glass, mirror...) to gas or liquid (water, oil, chemical...), it becomes possible to detect the location and the size of a cup in a coffee machine or beverage dispenser, to sense the floor material for robotics, and develop advanced shape, motion, or hand posture recognition.

The VL53L8CH integrates a powerful new generation VCSEL, and two advanced metasurface lenses. The integrated VCSEL emits fully invisible 940 nm IR light, which is Class 1 certified and safe for the eyes.

1 Acronyms and abbreviations

Acronym/abbreviation	Definition
AF	autofocus
API	application programming interface
AR/VR	augmented reality/virtual reality
DOE	diffractive optical element
ESD	electrostatic discharge
FoV	field of view
FoI	field of illumination
GPIO	general-purpose input/output
HP	high power
I ² C	inter-integrated circuit (serial bus)
LAF	laser autofocus
LGA	land grid array
LP	low power
MCLK	main serial clock
MISO	main input secondary output
MOSI	main output secondary input
NCS	chip select
NVM	non-volatile memory
PCB	printed circuit board
PDAF	phase detection autofocus
PLL	phase-locked loop
PVT	process, voltage, and temperature
POR	power on reset
RAM	random-access memory
SPAD	single photon avalanche diode
SW	software
ToF	Time-of-Flight
UI	user interface
UM	user manual
VCSEL	vertical-cavity surface-emitting laser

2 Product overview

2.1 Technical specifications

Table 1. Technical specifications

Feature	Detail
Package	Optical LGA16
Size	6.4 x 3.0 x 1.75 mm
Ranging	2 to 400 cm per zone
Operating voltage	AVDD: 3.3 V CORE_1V8: 1.8 V IOVDD: 1.2/1.8 V
Operating temperature	-30 to 85°C
Sample rate	Up to 60 Hz
Infrared emitter	940 nm
I ² C and SPI interface	I ² C: 1 MHz serial bus, address: 0x52 SPI: 3 MHz
Operating ranging mode	Continuous or autonomous (see UM3183 for more information)

2.2 Field of view

The Rx (or collector) exclusion zone includes all module assembly tolerances. It is used to define the cover glass dimensions. The cover glass opening must be equal to or wider than the exclusion zone.

The detection volume represents the applicative or system FoV in which a target is detected, and a distance measured. The Rx lens or the Rx aperture determines the detection volume. It is narrower than the exclusion zone.

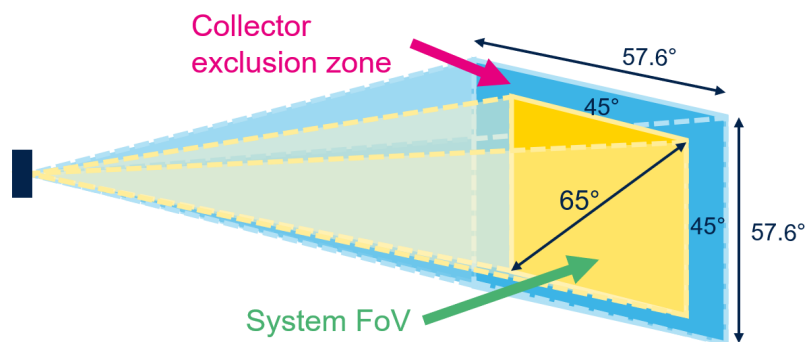
Figure 1. System FoV and exclusion zone description (not to scale)

Table 2. FoV angles

	Horizontal	Vertical	Diagonal
Detection volume	45°	45°	65°
Collector exclusion zone	57.6°	57.6°	85.9°

Note: The detection volume depends on the following: environment and sensor configuration, target distance, reflectance, ambient light level, sensor resolution, sharpener, ranging mode, and integration time.

Note: The detection volume of Table 2. FoV angles has been measured with a white 88% reflectance perpendicular target. This measurement was taken:

- In full FoV
- Located at 1 m from the sensor
- Without ambient light (dark conditions)
- With an 8x8 resolution
- With a 14% sharpener (default value)
- In continuous mode
- At 15 Hz

2.3 Field of illumination

The VCSEL field of illumination (Fol) is shown in the figure below. The relative emitted signal power depends on the Fol angle. It corresponds to:

- 43.4° x 43.4°, considering a beam with a 75% signal from the maximum.
- 57.9° x 57.9°, considering a beam with a 10% signal from the maximum.

Figure 2. VL53L8CH Fol

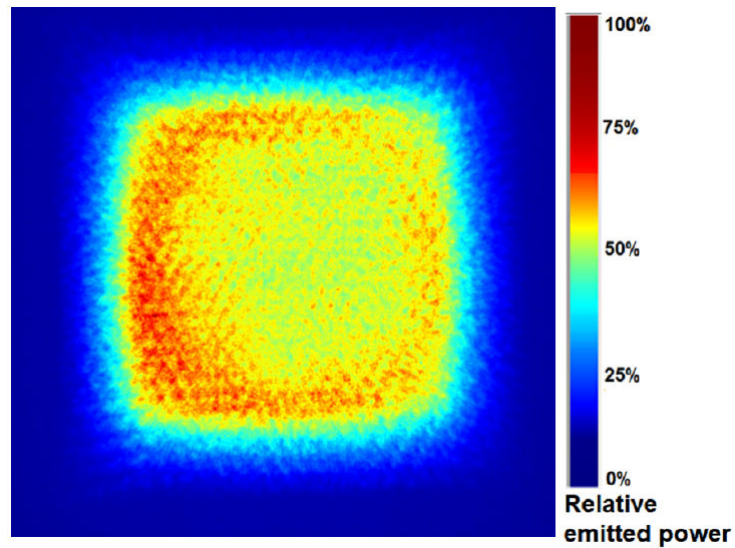

2.4 System block diagram

Figure 3. VL53L8CH block diagram

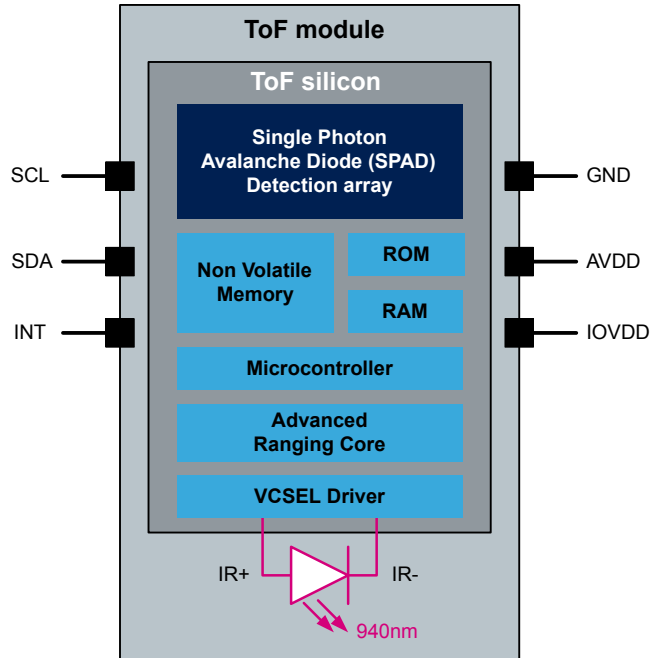

2.5 Device pinout

Figure 4. VL53L8CH pinout (bottom view) shows the pinout of the VL53L8CH.

Figure 4. VL53L8CH pinout (bottom view)

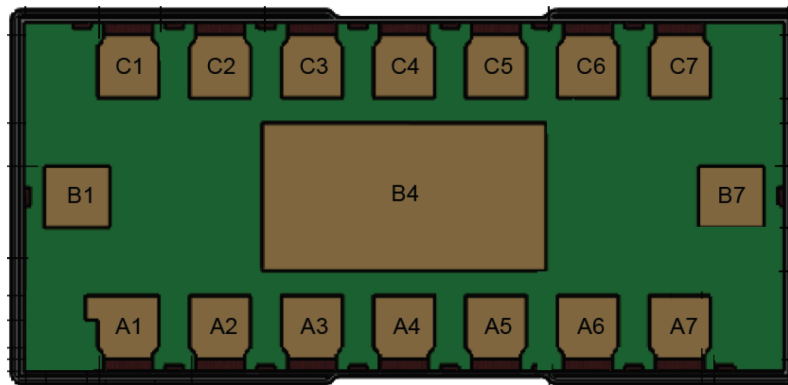

The VL53L8CH pin description for the I²C and SPI configuration is given in [Table 3. VL53L8CH pin description for I²C and SPI configuration](#). For the pins that support both I²C and SPI protocol, the I²C description is listed first and the SPI second.

Table 3. VL53L8CH pin description for I²C and SPI configuration

Pin number	Signal name	Signal type	Signal description
A1	GPIO1	Digital input/output (I/O)	General purpose I/O, defaults to open drain output (tristate), 47 kΩ pullup resistor to IOVDD required, used as INT output
A2	LPn	Digital input	Enables communication. Drive this pin to logic 0 to disable the I ² C communication. Drive this pin to logic 1 to enable the I ² C communication. This pin is typically used when you need to change the I ² C address in multidevice systems. If this pin is not being used, or if it is interfacing via the SPI, connect to IOVDD with a 47 kΩ pullup resistor.
A3	IOVDD	Power	1.2 V or 1.8 V I/O supply
A4	SDA / MOSI	Digital input/output (I/O)	I²C: Data (bidirectional), 2.2 kΩ pullup resistor required to IOVDD SPI: Main output secondary input
A5	SCL/MCLK	Digital input	I²C: Clock (input), 2.2 kΩ pullup resistor required to IOVDD SPI: Main clock
A6	RSVD1	Reserved	Connect to ground
A7	RSVD2	Reserved	Connect to ground
B1	GPIO2	Digital input/output (I/O)	General purpose I/O, defaults to open drain output (tristate), 47 kΩ pullup resistor required to IOVDD, used as SYNC input
B4	THERMALPAD	Ground	Connect to a ground plane to allow good thermal conduction
B7	CORE_1V8	Power	1.8 V analog core supply
C1	SPI_I2C_N	Digital input	I²C: Low value selects I ² C mode - Connect to GND with 47 kΩ pulldown resistor. Also used as I ² C interface reset pin, active high. Toggle this pin from 0 to 1, then back to 0 to reset the I ² C target. SPI: Connect to IOVDD with 47 kΩ pullup resistor
C2	NCS	Digital input	I²C: Not used - Connect to GND with 47 kΩ pulldown resistor SPI: Active low chip select. 47 kΩ pullup resistor required to IOVDD
C3	GND	Ground	Ground
C4	AVDD	Power	3.3 V analog and VCSEL supply
C5	MISO	Digital output	I²C: Do not connect SPI: Main input secondary output. Push-pull driven to IOVDD level
C6	RSVD3	Reserved	Connect to ground
C7	Ground	Ground	Ground

Note: The THERMALPAD pin has to be connected to ground (for more information refer to the AN5897).

Note: All digital signals must be driven to the IOVDD level.

Note: Toggling the SPI_I2C_N pin resets the sensor I²C communication only. It does not reset the sensor itself. To reset the sensor, refer to the sensor reset management procedure (UM3183).

2.6 Application schematics

Figure 5. Typical application schematic for I²C shows the application schematic of the VL53L8CH in I²C protocol configuration.

Figure 5. Typical application schematic for I²C

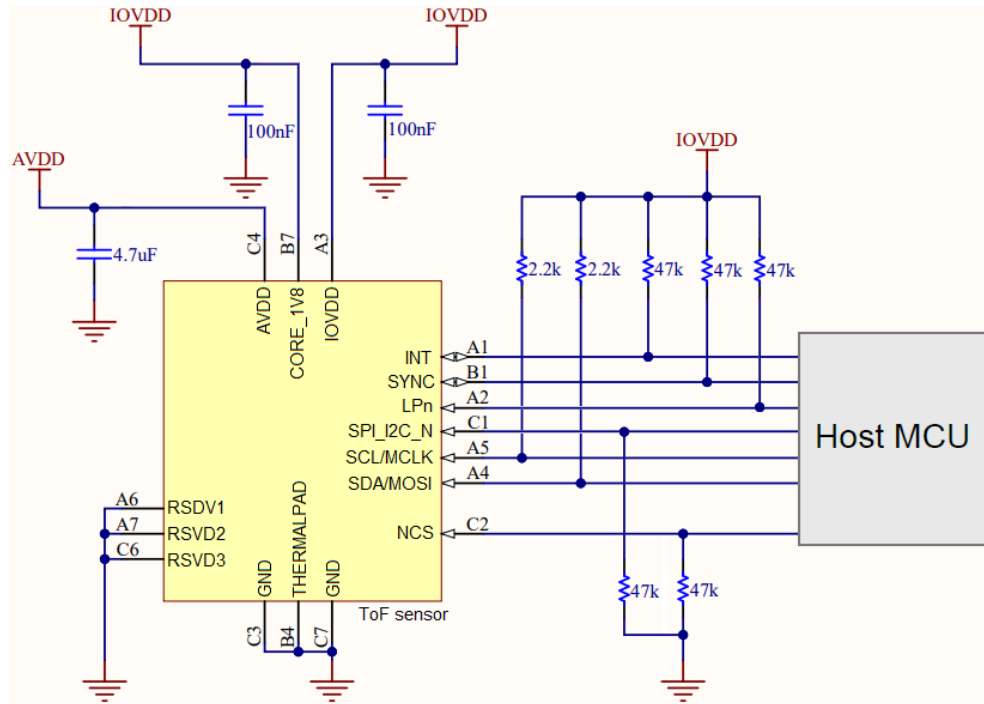

Note: Capacitors on the external supplies (AVDD, CORE_1V8, and IOVDD) should be placed as close as possible to the module pins.

Note: IOVDD must be set to ensure the host and the VL53L8CH operate at the same voltage levels for direct interfacing.

Figure 6. Typical application schematic for SPI shows the application schematic of the VL53L8CH in SPI protocol configuration.

Figure 6. Typical application schematic for SPI

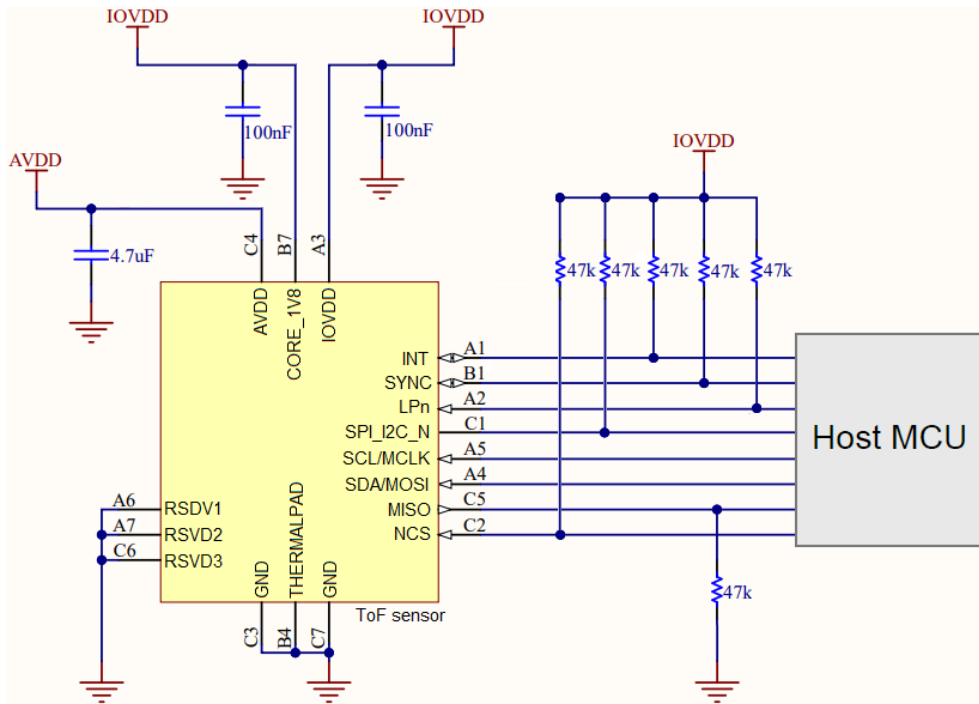

Note: Capacitors on the external supplies (AVDD, CORE_1V8, and IOVDD) should be placed as close as possible to the module pins.

Note: IOVDD must be set to ensure the host and the VL53L8CH operate at the same voltage levels for direct interfacing.

3 Functional description

3.1 Software interface

This section describes the software interface of the device. The host customer application controls the VL53L8CH using an application programming interface (API). The API implementation is delivered to the customer as a driver (C code and reference Linux® driver). The driver provides the customer application with a set of high level functions that allow control of the VL53L8CH firmware. This includes control of items such as device initialization, ranging start/stop, and mode select.

Figure 7. VL53L8CH system functional description

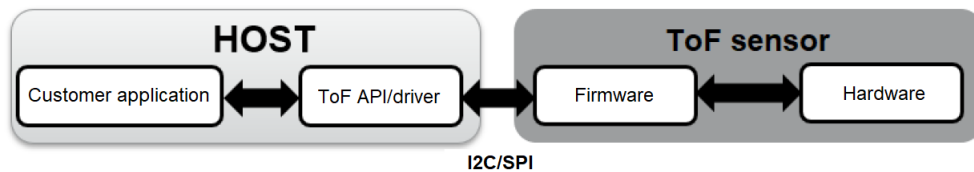

3.2 Power state machine

Figure 8. Power state machine

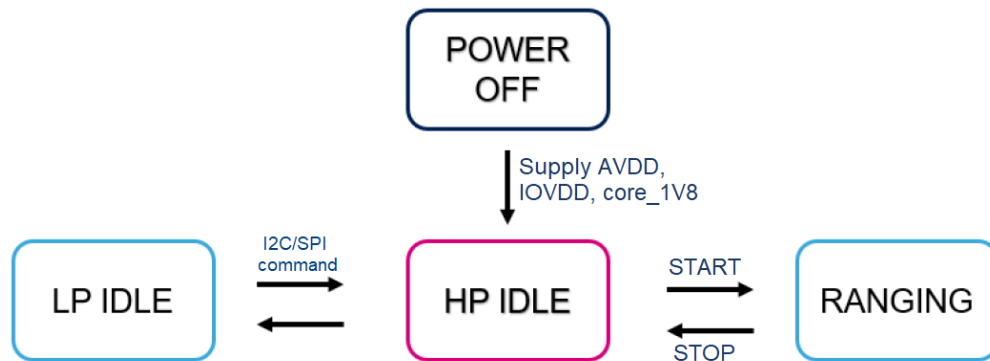

Table 4. Power state description

Device state	Description
LP idle	LP (low-power) idle state with data retention RAM and register content retained Allow fast resume to HP (high-power) I ² C communication disabled if using LPn
HP idle	HP idle state Device needs to be in HP idle state to start ranging Power up state
Ranging	Full operation VCSEL is active (pulsing)

3.3 Power up sequence

The VL53L8CH requires three power supplies:

- CORE_1V8: Analog core supply fixed at 1.8 V.
- AVDD: Analog and VCSEL supply fixed at 3.3 V.
- IOVDD: Voltage supply to the IO, which may be either 1.2 V or 1.8 V depending on the system it is integrated with. If IOVDD is 1.8 V, then the same supply may be used for both IOVDD and CORE_1V8.

The device requires three supplies to be fully operational (AVDD, IOVDD, CORE_1V8). The device stays in reset until all three supplies are applied. Power supplies may be applied in any sequence, or all at the same time.

To ensure proper operation of the module, the following minimum slew rates on the supplies (see [Figure 9. Power up slew](#)) must be met. This ensures correct operation of the power on the reset circuitry. The circuitry triggers at 0.9 V. However, the supplies should reach their operation levels in accordance with the slew rates listed in [Table 5. Supply slew minimum limits](#).

Figure 9. Power up slew



Note: The minimum reset time is the minimum time required for the device RAM to load and boot up after CORE_1V8 reaches the power-on reset rising threshold. The supply must have reached the minimum operating level (1.6 V) within this time.

Note: The AVDD rise time is determined by the internal analog levels, which must be stable for correct operation.

Note: CORE_1V8 and IOVDD are assumed to be the same supply (1V8) in [Figure 9. Power up slew](#). If using 1V2, then IOVDD should be applied at the same time as the other supplies.

Table 5. Supply slew minimum limits

Supply status	AVDD slew	CORE_1V8 slew	IOVDD slew
Start together	0.001 V/μs	0.012 V/μs	0.012 V/μs
AVDD stable followed by CORE_1V8 and IOVDD	—	0.012 V/μs	0.012 V/μs
CORE_1V8 stable followed by AVDD and IOVDD	0.001 V/μs	—	0.012 V/μs
IOVDD stable followed by AVDD and CORE_1V8	0.001 V/μs	0.012 V/μs	—

4 I²C control interface

This section specifies the control interface. The I²C interface uses two signals: serial data line (SDA) and serial clock line (SCL). Each device connected to the bus uses a unique address and a simple controller/target relationship exists.

Both SDA and SCL lines are connected to a positive supply voltage using pull-up resistors located on the host. Lines are only actively driven low. A high condition occurs when lines are floating and the pull-up resistors pull lines up. When no data is transmitted both lines are high.

The controller device performs the clock signal (SCL) generation and initiates data transfer. The I²C bus on the VL53L8CH has a maximum speed of 1 Mbit/s and uses a device 8-bit address of 0x52.

Figure 10. Data transfer protocol

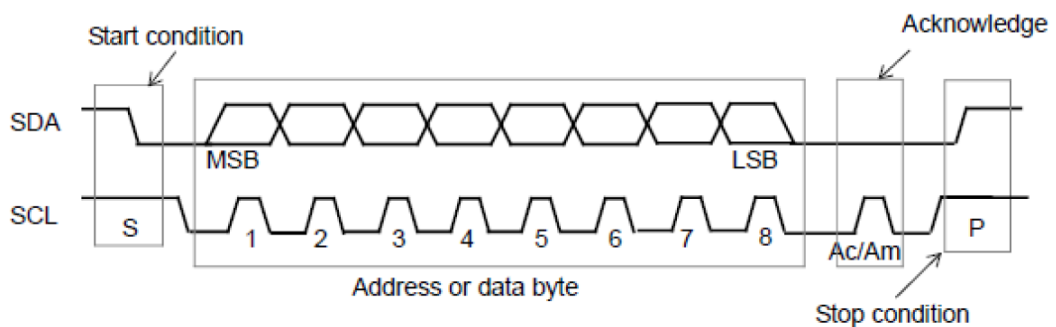

Information is packed in 8-bit packets (bytes) always followed by an acknowledge bit, Ac for VL53L8CH acknowledge and Am for controller acknowledge (host bus controller). The internal data is produced by sampling SDA at a rising edge of SCL. The external data must be stable during the high period of SCL. The exceptions to this are start (S) or stop (P) conditions when SDA falls or rises respectively, while SCL is high.

A message contains a series of bytes preceded by a start condition and followed by either a stop or repeated start (another start condition but without a preceding stop condition) followed by another message. The first byte contains the device address (0x52) and also specifies the data direction. If the least significant bit is low (that is, 0x52) the message is a controller-write-to-the-target. If the lsb is set (that is, 0x53) then the message is a controller-read-from-the-target.

Figure 11. VL53L8CH I²C device address: 0x52

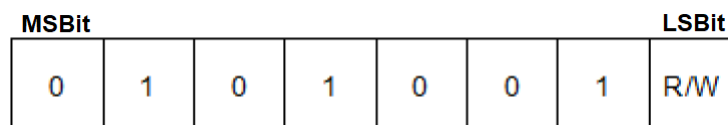

All serial interface communications with the Time-of-Flight sensor must begin with a start condition. The VL53L8CH module acknowledges the receipt of a valid address by driving the SDA wire low. The state of the read/write bit (lsb of the address byte) is stored and the next byte of data, sampled from the SDA, can be interpreted. During a write sequence, the second byte received provides a 16-bit index, which points to one of the internal 8-bit registers.

Figure 12. VL53L8CH data format (write)

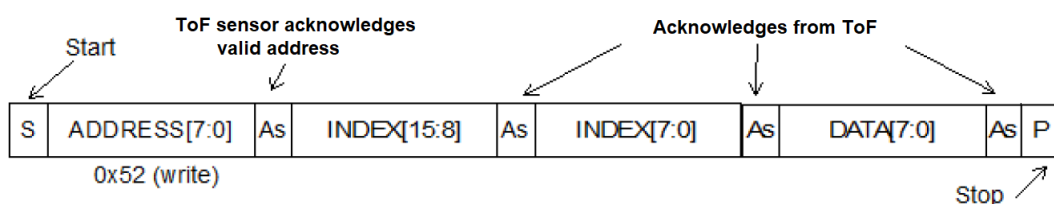

As data are received by the target, they are written bit by bit to a serial/parallel register. After each data byte has been received by the target, an acknowledge is generated, the data are then stored in the internal register addressed by the current index.

During a read message, the contents of the register addressed by the current index is read out in the byte following the device address byte. The contents of this register are parallel loaded into the serial/parallel register and clocked out of the device by the falling edge of SCL.

Figure 13. VL53L8CH data format (read)

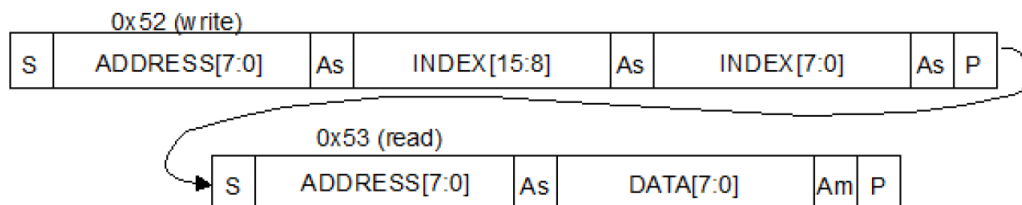

At the end of each byte, in both read and write message sequences, an acknowledge is issued by the receiving device (that is, the VL53L8CH for a write and the host for a read).

A message can only be terminated by the bus controller, either by issuing a stop condition or by a negative acknowledge (that is, not pulling the SDA line low) after reading a complete byte during a read operation.

The interface also supports autoincrement indexing. After the first data byte has been transferred, the index is automatically incremented by 1. The controller can therefore send data bytes continuously to the target until the target fails to provide an acknowledge or the controller terminates the write communication with a stop condition. If the autoincrement feature is used, the controller does **not** have to send address indexes to accompany the data bytes.

Figure 14. VL53L8CH data format (sequential write)

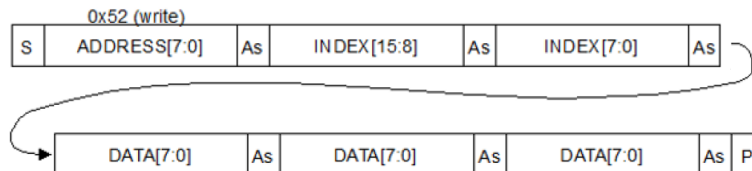
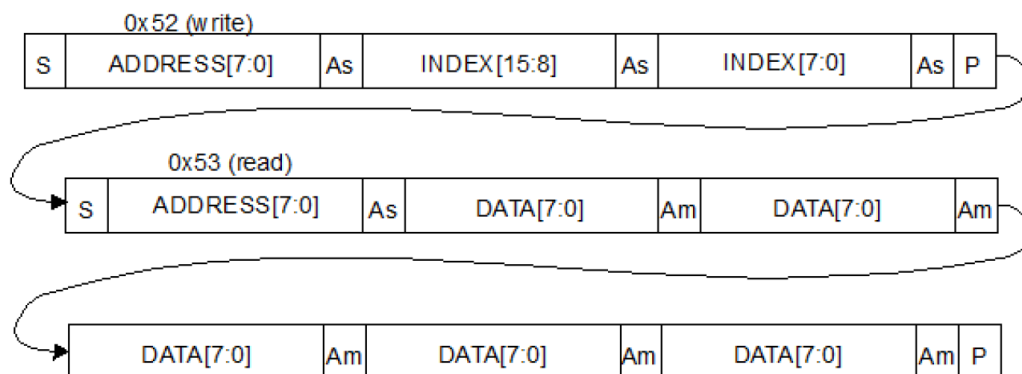

Figure 15. VL53L8CH data format (sequential read)



4.1 I²C interface - timing characteristics

Timing characteristics are shown in Table 6. I²C interface - timing characteristics for fast mode plus (1 MHz) and Table 7. I²C interface - timing characteristics for fast mode (400 kHz). Refer to Figure 16. I²C timing characteristics for an explanation of the parameters used.

Timings are given for all process, voltage, and temperature (PVT) conditions.

Table 6. I²C interface - timing characteristics for fast mode plus (1 MHz)

Symbol	Parameter	Minimum	Typical	Maximum	Unit
F _{I2C}	Operating frequency	0	—	1000	kHz
t _{LOW}	Clock pulse width low	0.5	—	—	μs
t _{HIGH}	Clock pulse width high	0.26	—	—	μs
t _{SP}	Pulse width of spikes, which are suppressed by the input filter	—	—	50	ns
t _{BUF}	Bus free time between transmissions	0.5	—	—	μs
t _{HD.STA}	Start hold time	0.26	—	—	μs
t _{SU.STA}	Start setup time	0.26	—	—	μs
t _{HD.DAT}	Data in hold time	0	—	0.9	μs
t _{SU.DAT}	Data in setup time	50	—	—	ns
t _R	SCL/SDA rise time	—	—	120	ns
t _F	SCL/SDA fall time	—	—	120	ns
t _{SU.STO}	Stop setup time	0.26	—	—	μs
C _{i/o}	Input/output capacitance (SDA)	—	—	10	pF
C _{in}	Input capacitance (SCL)	—	—	4	pF
C _L	Load capacitance (1V8)	—	140	550	pF
	Load capacitance (1V2)	—	140	150	pF

Table 7. I²C interface - timing characteristics for fast mode (400 kHz)

Symbol	Parameter	Minimum	Typical	Maximum	Unit
F _{I2C}	Operating frequency	0	—	400	kHz
t _{LOW}	Clock pulse width low	1.3	—	—	µs
t _{HIGH}	Clock pulse width high	0.6	—	—	µs
t _{SP}	Pulse width of spikes, which are suppressed by the input filter	—	—	50	ns
t _{BUF}	Bus free time between transmissions	1.3	—	—	µs
t _{HD.STA}	Start hold time	0.26	—	—	µs
t _{SU.STA}	Start setup time	0.26	—	—	µs
t _{HD.DAT}	Data in hold time	0	—	0.9	µs
t _{SU.DAT}	Data in setup time	50	—	—	ns
t _R	SCL/SDA rise time	—	—	300	ns
t _F	SCL/SDA fall time	—	—	300	ns
t _{SU.STO}	Stop setup time	0.6	—	—	µs
C _{i/o}	Input/output capacitance (SDA)	—	—	10	pF
C _{in}	Input capacitance (SCL)	—	—	4	pF
C _L	Load capacitance (1V8)	—	125	400	pF
	Load capacitance (1V2)	—	125	400	pF

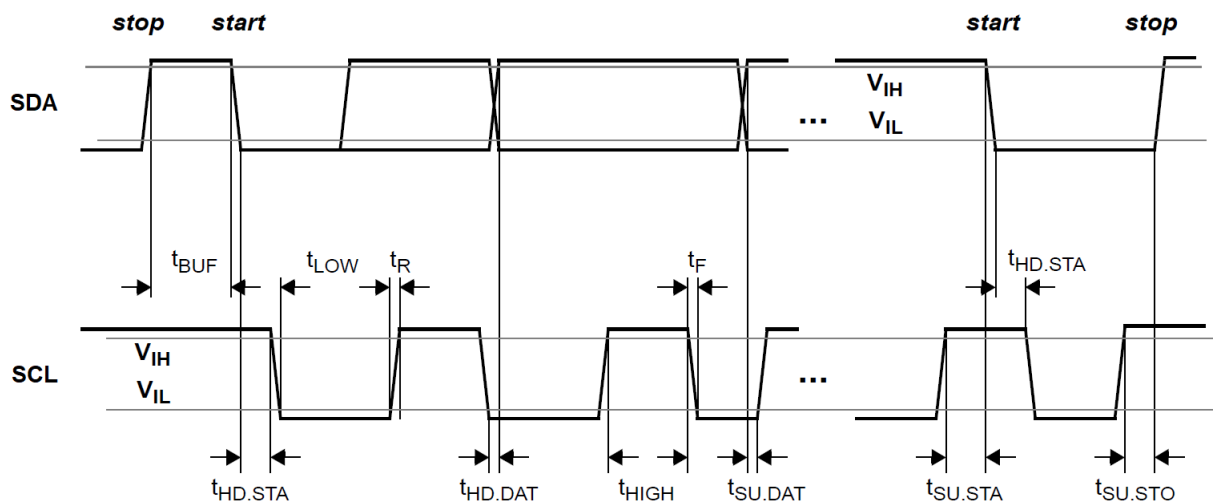
Figure 16. I²C timing characteristics

5 SPI timing specification

This section specifies the SPI control interface used to control data transfer.

The communication interface is based on a 4-wire, serial, synchronous interface between the host (controller) and the VL53L8CH (target device). Refer to the schematics in [Section 2.6: Application schematics](#). The 4-wire interface comprises the following four signals:

- NCS: Chip select (active low)
- MCLK: Main serial clock
- MOSI: Main output secondary input, data output from controller
- MISO: Main input secondary output, data output from target

All signals are CMOS inputs/outputs. Their levels are in line with the IOVDD supply. The SPI modes supported are clock polarity = 1 and clock phase = 1. These modes correspond to data captured on a clock's rising edge and data propagated on a falling edge. The controller selects the target device with the NCS. The NCS enables target transmission. It is an active low signal. After the device is selected with the falling edge of the NCS, an 8-bit command can be received. If the VL53L8CH has not been activated using the NCS chip select line, the MCLK input clock and MOSI signals are disregarded.

The falling edge (high to low transition) of the NCS signal is required to initiate an action. The transmission ends with the rising edge (low-to-high transition). This causes the end of data transfer, and resets the internal counter and command registers. All this reinitializes the serial communication.

While the register address is applied on the MOSI pin, the same information is mirrored on the MISO pin.

The NCS can be reset to a noncommunication state (high) at any time, including during a transaction. Should this happen, the device resets its internal state machine. Consequently, any ongoing communications are aborted. No internal changes to the registers occur, and the interface is ready to receive a new transaction again. However, the SPI target can tolerate the MCLK being interrupted. It can resume at any point in time, without specific duration limit.

During each SPI clock cycle, a full duplex data transmission occurs. The MOSI input is the data signal, provided by the host to the device. It carries both the address and data information in write mode. Only address information is in read mode. The controller sends a bit on the MOSI line and the target reads it. Concurrently, the target sends a bit on the MISO line and the controller reads it. This sequence is maintained even when only one-directional data transfer is intended.

The MISO output is the data signal, provided by the device to the host. It carries the data in read mode only, and the mode register content during the address setup. Any internal register that can be written to, can also be read from. There are also read-only registers that contain device status information. For example, design revision details. A read instruction from an unused register location returns the value 0x00. A read instruction from the manufacturer's specific registers may return any value. A write instruction to a reserved or unused register location is illegal. The effect of such a write is ignored. Transmission may continue for any number of clock cycles. When complete, the controller stops toggling the clock signal, and typically deselects the target.

Table 8. SPI interface timing specification

Parameter	Symbol	Min.	Max.	Unit	Notes
Operating frequency	F_{spi}	—	3	MHz	MCLK
Time from NCS active and MCLK falling edge	$T_{ncs_to_clk}$	0	—	ns	
Rise/Fall time on MISO	$T_{riseFallMiso}$	—	3	ns	With 20 pF load max
Duty cycle	Duty	40	60	%	
Time from MOSI stable to MCLK rising edge	$T_{mosi_to_clk}$	16	—	ns	
Time MOSI must remain stable after MCLK rising edge	$T_{clk_to_ncs}$	16	—	ns	
Time from last MCLK rising edge to NCS going inactive	$T_{clk_to_dat}$	0	—	ns	
Propagation delay from falling MCLK edge to MISO data valid		—	20	ns	With 20 pF load max

5.1 SPI write messages

The write timing sequence is shown in [Figure 17. SPI writing timing sequence](#). Once the NCS selects the device, the controller sends a write command to the VL53L8CH. The controller then provides a clock to output the status. The writing sequence starts with the MOSI initial value equal to 1. The address is sent first, and the data is sent afterwards. The most significant bit is sent first (big endian format). The address length is 15 bits. Data length is 8 bits.

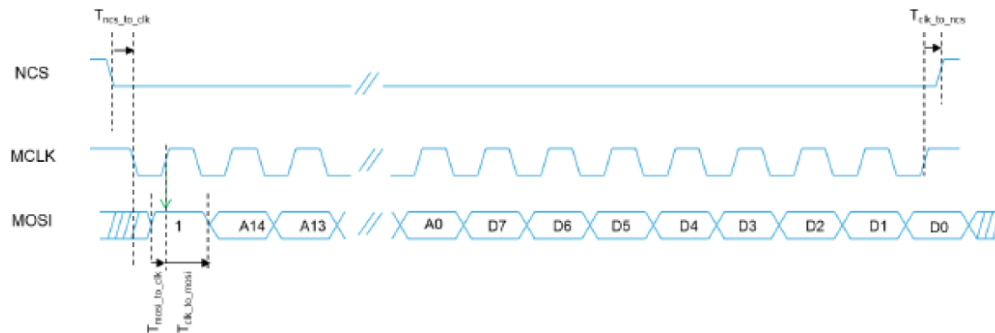
Figure 17. SPI writing timing sequence

If the host continues to transmit data beyond the first 8 data bits, then the target goes into autoincrement write mode. The autoincrement write timing sequence is shown in [Figure 18. SPI autoincrement write sequence](#). The MOSI initial value is 1. The address is incremented automatically and internally by the target. Subsequent data bits correspond to incrementing addresses.

Figure 18. SPI autoincrement write sequence

5.2 SPI read messages

The controller sends the read command to the VL53L8CH. The controller then provides a clock to output the status.

In read mode, the target writes the data to the controller. Transmission is ended by the controller. The reading sequence starts with the first value of the MOSI equal to 0. The most significant bit is sent first (big endian format). Once the last bit of the address has been received, the device fetches the data internally. The device then presents the data onto the MISO pin by the next falling MCLK edge (half the MCLK period). This enables the host to sample the data on the following rising edge. Once 8 bits of data have been received, the host sets the NCS high. This terminates the process. More details of the SPI read timing are shown in [Figure 19. SPI read timing](#).

Figure 19. SPI read timing

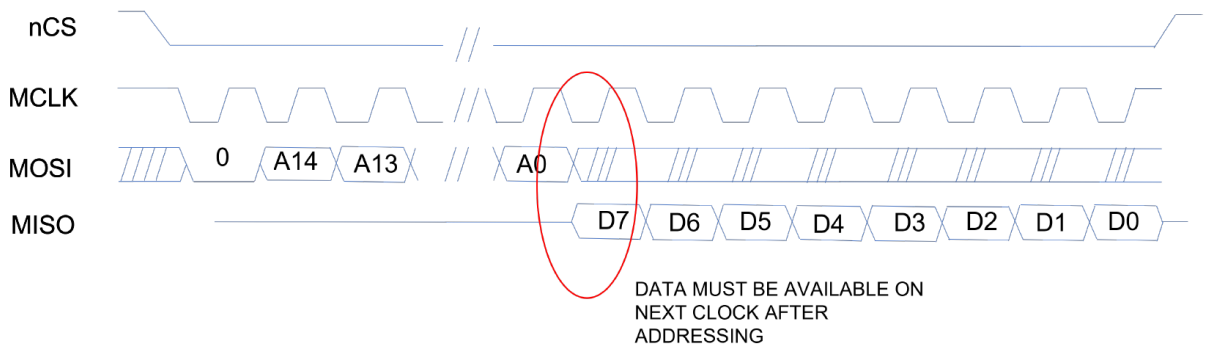

If the host continues to toggle the MCLK after the last data bit has been read, the target goes into autoincrement read mode. In this mode, the address is automatically incremented by the target, and the read data are transmitted sequentially to the controller on the MISO line. More details of the SPI autoincrement read mode are shown in [Figure 20. SPI autoincrement read sequence](#).

Figure 20. SPI autoincrement read sequence

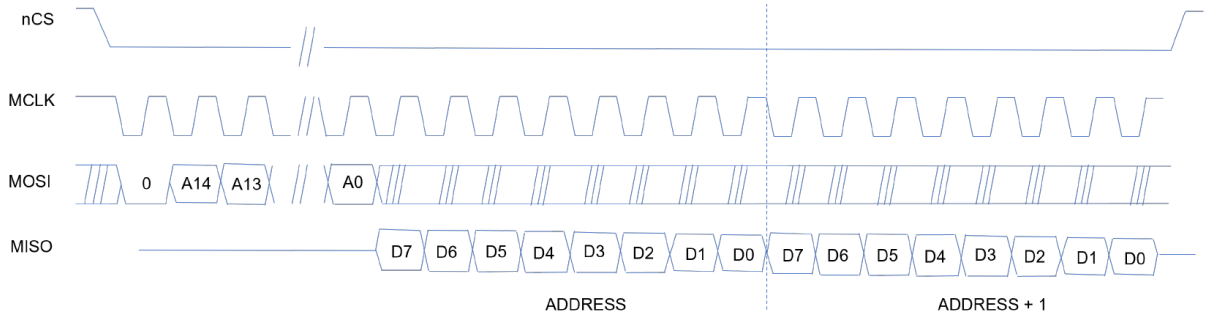

6 Thermal characteristics

6.1 Absolute maximum rating (T_{STG})

Warning: Stresses above those listed in the following table may cause permanent damage to the device. These are stress ratings only. Functional operation of the device is not implied at these or any other conditions above those indicated in the operational sections of the specification. Exposure to absolute maximum rating conditions for extended periods may affect device reliability.

The storage temperature (T_{STG}) is the ambient temperature at which the device can be stored with no voltage applied.

Table 9. Absolute maximum rating conditions

Parameter	Min.	Max.	Unit
Storage temperature (T_{STG})	-40	125	°C

6.2 Ambient operating temperature

The ambient operating temperature is the temperature at which the device may be powered and can operate without any damage.

Table 10. Recommended operating temperature

Parameter	Min.	Max.	Unit
Ambient operating temperature	-30	85	°C

7 Electrical characteristics

7.1 Absolute maximum ratings

Table 11. Absolute maximum ratings

Parameter	Min.	Typ.	Max.	Unit
AVDD	-0.5	—	3.47	V
CORE_1V8	-0.5	—	1.98	
IOVDD	-0.5	—	1.98	

Note: Stresses above those listed above may cause permanent damage to the device. This is a stress rating only. Functional operation of the device at these or any other conditions above those indicated in the operational sections of the specification is not implied. Exposure to absolute maximum rating conditions for extended periods may affect device reliability.

7.2 Recommended operating conditions

Table 12. Recommended operating conditions

Parameter	Min.	Typ.	Max.	Unit
AVDD supply	3.13	3.3	3.47	V
CORE_1V8 supply	1.62	1.8	1.98	
IOVDD supply with 1.2 V configuration	1.08	1.2	1.32	
IOVDD supply with 1.8 V configuration	1.62	1.8	1.98	

Note: All three supplies are independent.

Note: When IOVDD is 1.8 V, it is recommended to use the same supply as CORE_1V8.

7.3 Electrostatic discharge (ESD)

The VL53L8CH is compliant with the ESD values presented in Table 13. ESD performance.

Table 13. ESD performance

Parameter	Specification	Conditions
Human body model	JEDEC JS-001-2014	± 2 kV, 1500 Ω, 100 pF
Charged body model	JEDEC JS-001-2014	± 500 V

7.4 Current consumption

The current consumption values are given in Table 14. Current consumption.

- Typical values quoted are for nominal voltage, process, and temperature (23°C).
- Maximum values are quoted for the worst case conditions (process, voltage, and temperature), unless stated otherwise (85°C)

Table 14. Current consumption

Device state	Average current consumption						Unit
	AVDD		CORE_1V8		IOVDD		
	Typ.	Max.	Typ.	Max.	Typ.	Max.	
LP idle	55	390	0.01	0.5	0.5	2	µA
HP idle	1	1.6	3	17	0.0003	0.002	mA
Active ranging	43	50	50	80	0.003	0.006	

Note: Active ranging is when the device is actively ranging. The current consumption is not affected by a 4x4 or 8x8 zone configuration.

- CORE_1V8 peak current is the average value +10 mA.
- AVDD peak current is the average current +10 mA.
- IOVDD peak current is the average value +10 mA.

Table 15. Example of typical power consumption in continuous mode

Parameter	AVDD 3.3 V IOVDD/CORE_1V8 1.8V	Unit
Continuous mode (4x4 or 8x8 mode)	215	mW

Table 16. Example of typical power consumption in autonomous mode

Parameter	AVDD 3.3 V IOVDD/CORE_1V8 1.8V	Unit
4x4 mode 1 Hz frame rate with 5 ms integration time	1.6	mW
4x4 mode 5 Hz frame rate with 5 ms integration time	12.5	
8x8 mode 1 Hz frame rate with 5 ms integration time	6.7	
8x8 mode 5 Hz frame rate with 5 ms integration time	32.3	

7.5 Digital input and output

Table 17. I²C, SPI, INT, and SYNC summarize the digital I/O electrical characteristics.

Table 17. I²C, SPI, INT, and SYNC

Symbol	Parameter	IOVDD configuration	Min.	Max.	Unit
V _{IL}	Low-level input voltage	1.2/1.8V	-0.3	0.3*IOVDD	V
V _{IH}	High-level input voltage	V1.2/1.8V	0.7*IOVDD	IOVDD + 0.3	
V _{OL}	Low-level output voltage (I _{OUT} = 4 mA)	1.2/1.8V	—	0.2*IOVDD	
V _{OH}	High-level output voltage (I _{OUT} = 4 mA)	1.2/1.8V	0.8*IOVDD	—	

Note: The I_{OUT} is not applicable for open drain pins.

8 Histogram (CNH) output

Up to 6 KB of histogram data can be read by the host at every frame. Selection of what histogram data is placed in this 6 KB data area is highly configurable, allowing the amount of the data transferred to be optimized for different applications. The format of the collected histogram data is called compact normalized histogram (CNH):

- Compact: Options are available to reduce the amount of data compared to the native “raw” histogram data
- Normalized: Raw data are adjusted to compensate variations caused by frame-to-frame adjustments
- Histogram: Primary data is in the form of histograms recording return-signal-strength vs range

Figure 21. Raw histogram (128 bins)

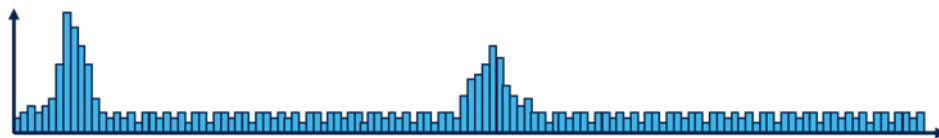

The sensor is highly configurable. The user can program the number of bins, bin width, and also the region-of-interest. Ambient light level is measured during ranging, and is later removed from the histogram data. A record of the ambient light level that was removed from each histogram is available in a separate area of the data result buffer.

Data aggregation options during preprocessing include region-of-interest and subsampling operations both spatially (zone based), and temporally (on histogram bins).

Table 18. ToF ranging core histogram characteristics

Parameter	Value	Units
Ranging core histogram bin width	250	ps
Ranging core histogram bin equivalent range	37.5	mm
Ranging core number of bins in histogram	128	bins

Table 19. CNH parameters

Setting	Value	Units
CNH buffer maximum size	6160	bytes
Bytes-per-histogram bin	5	bytes
Maximum zones per CNH aggregate	64	zones
Maximum histogram binning factor	8	—
Bytes-per-ambient level	5	bytes

Note: Details of the CNH configuration options available can be found in the user manual UM3183.

Table 20. Example operating configurations

Number of histograms	Bins per CNH histogram	CNH data size (bytes)	Transfer time (ms)	Framerate (fps)
8	80	3268	32	30
8	128	5188	48	20
16	48	3948	36	25
16	72	5868	54	18
32	36	6108	56	15
64	18	6108	56	15

Note: Data transfer timing is for the I²C interface with an SCL clock at 1 MHz. CNH data size includes histogram and ambient light level data. No per-zone target data are included in the data transfer. Details of how to configure such operating modes can be found in the user manual UM3183.

Figure 22. CNH example 1 (18 bins selected, binning factor = 1)

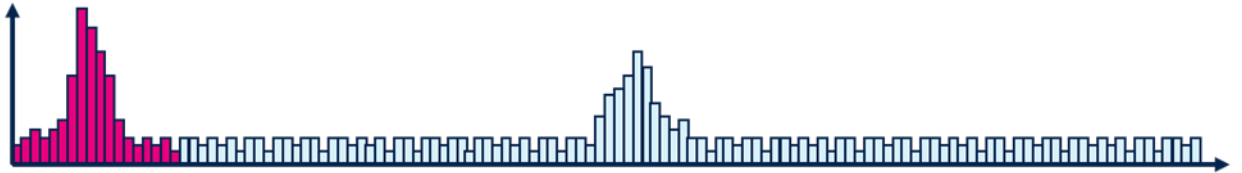
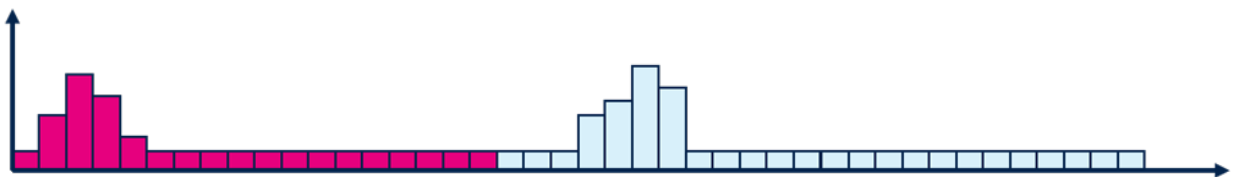

Figure 23. CNH example 2 (18 bins selected, binning factor = 3)



9 Ranging performances

9.1 Zone mapping

9.1.1 Zone mapping 4x4

Figure 24. Zone mapping in 4x4 mode shows the zone definition in 4x4 mode. There are 16 zones in total. They increment along a row first before starting a new row. The physical view is from the device top into the lens. The number of zones, as indicated in Figure 24. Zone mapping in 4x4 mode, corresponds to the zone IDs returned by the sensor.

Figure 24. Zone mapping in 4x4 mode

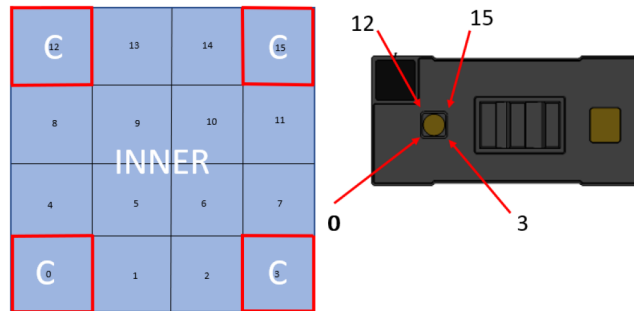

C = Corner zones
INNER = all zones not identified as the corner

9.1.2 Zone mapping 8x8

Figure 25. Zone mapping in 8x8 mode shows the zone definition in 8x8 mode. There are 64 zones in total. They increment along a row first before starting a new row. The physical view is from the device top into the lens. The number of zones, as indicated in Figure 25. Zone mapping in 8x8 mode, correspond to the zone IDs returned by the sensor to the host.

Figure 25. Zone mapping in 8x8 mode

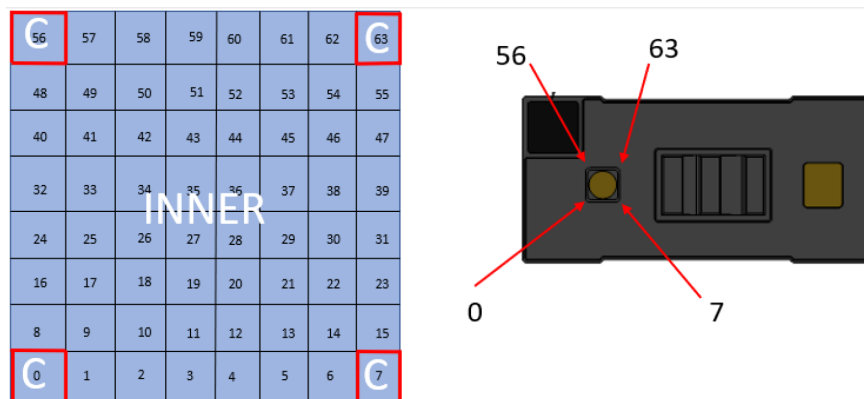

C = Corner zones
INNER = all zones not identified as the corner

9.1.3 Effective zone orientation

The VL53L8CH module includes a lens over the Rx aperture, which flips (horizontally and vertically) the captured image of the target. Consequently, the zone identified as zone 0, in the bottom left of the SPAD array (see Figure 26. Effective orientation), is illuminated by a target. This target is located at the top right-hand side of the scene.

Figure 26. Effective orientation

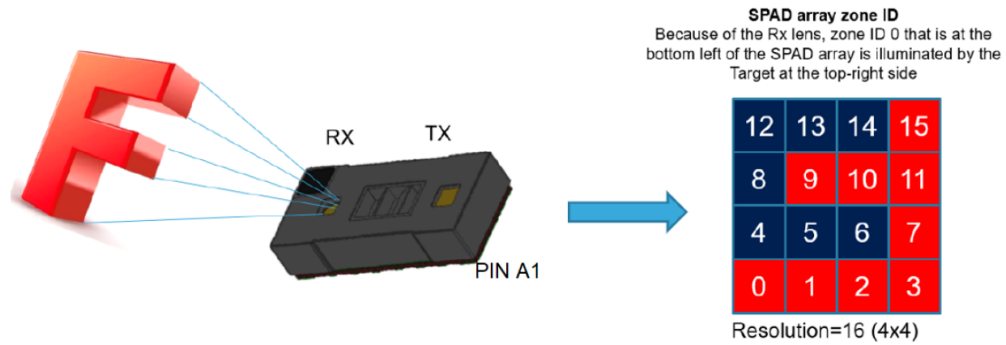

9.2 Continuous ranging mode

9.2.1 Measurement conditions

The following criteria and test conditions apply to all the characterization results detailed in this section unless specified otherwise:

- The specified target fills 100% of the FoV of the device (in all zones).
- Targets used are Munsell N4.75 (17%), Munsell N8.25 (54%), and Munsell N9.5 (88%).
- AVDD is 3.3 V, IOVDD is 1.8 V, and CORE_1V8 is 1.8 V.
- Nominal ambient temperature is 23°C.
- Maximum range capability is based on a 90% detection rate. ⁽¹⁾
- Range accuracy figures are based on 2.7 sigma. This means that 99.3% of measurements are within the specified accuracy.
- Tests are performed in the dark and at 2 W/m² target illumination (940 nm). A 2 W/m² target irradiance at 940 nm is equivalent to 5 kLux daylight.
- All tests are performed without cover glasses with a crosstalk margin set to 0 kcps.
- The sensor relies on default calibration data.
- The device is controlled through the API using the default driver settings.

1. *Detection rate is a statistical value indicating the worst case percentage of measurements that return a valid ranging. For example, taking 1000 measurements with a 90% detection rate, gives 900 valid distances. The 100 other distances may be outside the specification, or flagged with an invalid target status.*

9.2.2 Maximum ranging distance 4x4

Table 21. Maximum ranging capabilities when ranging continuously at 30 Hz shows the maximum ranging capability of the VL53L8CH under different conditions. Refer to Section 9.2.1: Measurement conditions for the general test conditions.

Table 21. Maximum ranging capabilities when ranging continuously at 30 Hz

Target reflectance level. Full FoV (reflectance %)	Zone	Dark	Ambient light (5 kLux)
White target (88%)	Inner	Typical 4000 mm Minimum 4000 mm	Typical 2850 mm Minimum 2850 mm
	Corner	Typical 4000 mm Minimum 4000 mm	Typical 2850 mm Minimum 2700 mm
Light gray target (54%)	Inner	Typical 4000 mm Minimum 4000 mm	Typical 2600 mm Minimum 2550 mm
	Corner	Typical 4000 mm Minimum 4000 mm	Typical 2500 mm Minimum 2400 mm
Gray target (17%)	Inner	Typical 4000 mm Minimum 4000 mm	Typical 1650 mm Minimum 1600 mm
	Corner	Typical 3950 mm Minimum 3900 mm	Typical 1550 mm Minimum 1500 mm

9.2.3 Maximum ranging distance 8x8

Table 22. Maximum ranging capabilities when ranging continuously at 15 Hz shows the maximum ranging capability of the VL53L8CH under different conditions. Refer to Section 9.2.1: Measurement conditions for the general test conditions.

Table 22. Maximum ranging capabilities when ranging continuously at 15 Hz

Target reflectance level. Full FoV (reflectance %)	Zone	Dark	Ambient light (5 kLux)
White target (88%)	Inner	Typical 4000 mm Minimum 4000 mm	Typical 1550 mm Minimum 1100 mm
	Corner	Typical 3950 mm Minimum 2900 mm	Typical 1400 mm Minimum 1100 mm
Light gray target (54%)	Inner	Typical 3300 mm Minimum 2350 mm	Typical 1400 mm Minimum 1000 mm
	Corner	Typical 3100 mm Minimum 2100 mm	Typical 1250 mm Minimum 950 mm
Gray target (17%)	Inner	Typical 2450 mm Minimum 1500 mm	Typical 1150 mm Minimum 900 mm
	Corner	Typical 1950 mm Minimum 1300 mm	Typical 950 mm Minimum 700 mm

9.2.4 Range accuracy in continuous mode

Figure 27. Range accuracy vs distance illustrates how range accuracy is defined over distance.

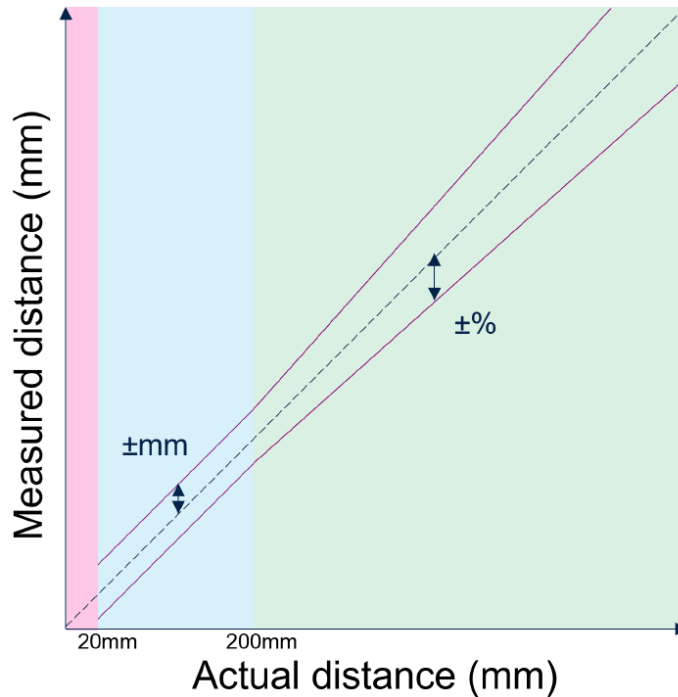
Figure 27. Range accuracy vs distance

Table 23. Range accuracy in continuous mode

Mode	Distance	Target reflectance	Dark (0 kLux)	Ambient light (5 kLux)
4x4 at 30 Hz	20-200 mm	White target (88%)	±10 mm	±12 mm
		Light gray target (54%)	±9 mm	±11 mm
		Gray target (17%)	±8 mm	±10 mm
	200-4000 mm	White target (88%)	±3%	±4%
		Light gray target (54%)	±4%	±6%
		Gray target (17%)	±4%	±7%
8x8 at 15 Hz	20-200 mm	White target (88%)	±11 mm	±10 mm
		Light gray target (54%)	±12 mm	±13 mm
		Gray target (17%)	±12 mm	±14 mm
	200-4000 mm	White target (88%)	±5%	±5%
		Light gray target (54%)	±5%	±6%
		Gray target (17%)	±5%	±8%

Note: The accuracy of the corner zone data compared to the center 4 zones may degrade by up to 4%.

Note: The accuracy in Table 23. Range accuracy in continuous mode assumes a correctly mounted module. Final assemblies should include additional tolerance for PCB assembly tilt, and mounting of the PCB in a product housing. Typically an additional 1~2%.

9.3 Autonomous ranging mode

9.3.1 Measurement conditions

The following criteria and test conditions apply to all the characterization results detailed in this section unless specified otherwise:

- The specified target fills 100% of the FoV of the device (in all zones).
- Targets used are Munsell N4.75 (17%), Munsell N8.25 (54%), and Munsell N9.5 (88%).
- AVDD is 3.3 V, IOVDD is 1.8 V, and CORE_1V8 is 1.8 V.
- Nominal ambient temperature is 23°C.
- Maximum range capability is based on a 90% detection rate. ⁽¹⁾
- Range accuracy figures are based on 2.7 sigma. This means that 99.3% of measurements are within the specified accuracy.
- Tests are performed in the dark and at 2 W/m² target illumination (940 nm). A 2 W/m² target irradiance at 940 nm is equivalent to 5 kLux daylight.
- All tests are performed without cover glasses with a crosstalk margin set to 0 kcps.
- The sensor relies on default calibration data.
- The device is controlled through the API using the default driver settings.

1. *Detection rate is a statistical value indicating the worst case percentage of measurements that return a valid ranging. For example, taking 1000 measurements with a 90% detection rate, gives 900 valid distances. The 100 other distances may be outside the specification, or flagged with an invalid target status.*

9.3.2 Maximum ranging distance 4x4

Table 24. Maximum ranging capabilities when ranging with autonomous mode at 1 Hz – 4x4 – integration time 5 ms shows the maximum ranging capability of the VL53L8CH under different conditions. Refer to Section 9.2.1: Measurement conditions for the general test conditions.

Table 24. Maximum ranging capabilities when ranging with autonomous mode at 1 Hz – 4x4 – integration time 5 ms

Target reflectance level. Full FoV (reflectance %)	Zone	Dark	Ambient light (5 klx)
White target (88%)	Inner	Typical 4000 mm Minimum 4000 mm	Typical 1550 mm Minimum 1100 mm
	Corner	Typical 4000 mm Minimum 4000 mm	Typical 1400 mm Minimum 1100 mm
Light gray target (54%)	Inner	Typical 4000 mm Minimum 4000 mm	Typical 1450 mm Minimum 1100 mm
	Corner	Typical 3700 mm Minimum 3500 mm	Typical 1300 mm Minimum 1100 mm
Gray target (17%)	Inner	Typical 3000 mm Minimum 3000 mm	Typical 1350 mm Minimum 1100 mm
	Corner	Typical 2550 mm Minimum 2400 mm	Typical 1200 mm Minimum 1000 mm

9.3.3 Maximum ranging distance 8x8

Table 25. Maximum ranging capabilities when ranging with autonomous mode at 1 Hz – 8x8 – integration time 5 ms shows the maximum ranging capability of the VL53L8CH under different conditions. Refer to Section 9.2.1: [Measurement conditions](#) for the general test conditions.

Table 25. Maximum ranging capabilities when ranging with autonomous mode at 1 Hz – 8x8 – integration time 5 ms

Target reflectance level. Full FoV (reflectance %)	Zone	Dark	Ambient light (5 klx)
White target (88%)	Inner	Typical 3600 mm Minimum 2400 mm	Typical 1250 mm Minimum 1000 mm
	Corner	Typical 2850 mm Minimum 1700 mm	Typical 1150 mm Minimum 800 mm
Light gray target (54%)	Inner	Typical 2600 mm Minimum 1900 mm	Typical 1100 mm Minimum 900 mm
	Corner	Typical 2200 mm Minimum 1350 mm	Typical 1000 mm Minimum 750 mm
Gray target (17%)	Inner	Typical 1400 mm Minimum 1200 mm	Typical 850 mm Minimum 800 mm
	Corner	Typical 1350 mm Minimum 900 mm	Typical 700 mm Minimum 700 mm

9.3.4 Range accuracy in autonomous mode

Figure 28. Range accuracy vs distance illustrates how range accuracy is defined over distance.

Figure 28. Range accuracy vs distance

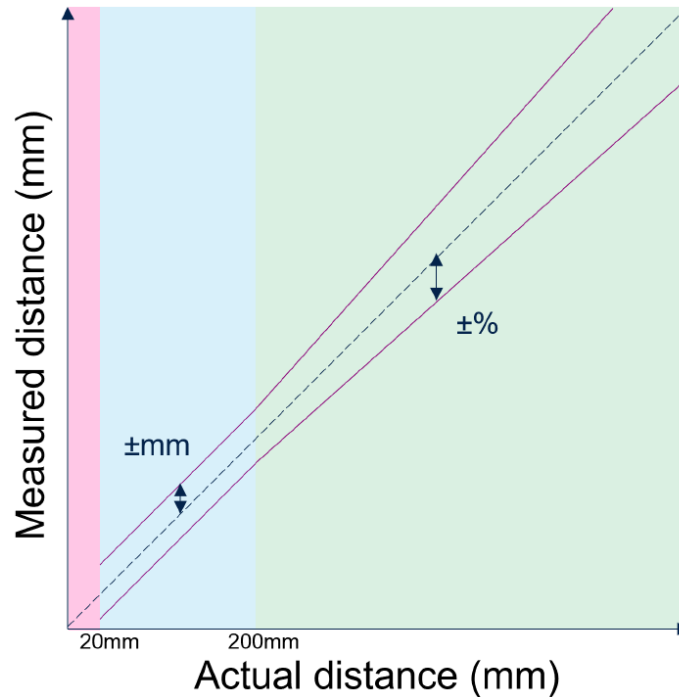

Table 26. Range accuracy in autonomous mode

Mode	Distance	Target reflectance	Dark (0 kLux)	Ambient light (5 kLux)
4x4 at 1 Hz and 5 ms integration time	20-200 mm	White target (88%)	±11 mm	±12 mm
		Light gray target (54%)	±10 mm	±12 mm
		Gray target (17%)	±10 mm	±14 mm
	200-4000 mm	White target (88%)	±3%	±5%
		Light gray target (54%)	±4%	±6%
		Gray target (17%)	±4%	±8%
8x8 at 1 Hz and 5 ms integration time	20-200 mm	White target (88%)	±10 mm	±10 mm
		Light gray target (54%)	±10 mm	±12 mm
		Gray target (17%)	±11 mm	±14 mm
	200-4000 mm	White target (88%)	±5%	±6%
		Light gray target (54%)	±6%	±8%
		Gray target (17%)	±6%	±11%

Note: The accuracy of the corner zone data compared to the center 4 zones may degrade by up to 4%.

Note: The accuracy in Table 26. Range accuracy in autonomous mode assumes a correctly mounted module. Final assemblies should include additional tolerance for a PCB assembly tilt, and mounting of the PCB in a product housing. Typically an additional 1~2%.

9.4 Range offset drift over temperature

Self-heating or a change in ambient temperature increases silicon temperature. This results in a range offset drift. This may be minimized by performing a periodic autocalibration, resulting in a typical drift of 0.1 mm/°C.

The autocalibration is done automatically when a new ranging session is started. A stop/start of the device is required if the device is already streaming.

10 Outline drawings

The figures below give details of the VL53L8CH module. All values are given in millimeters.

Note: The module drawings below are based on DM00891572 rev 2.0.

Figure 29. Outline drawing (1/4)

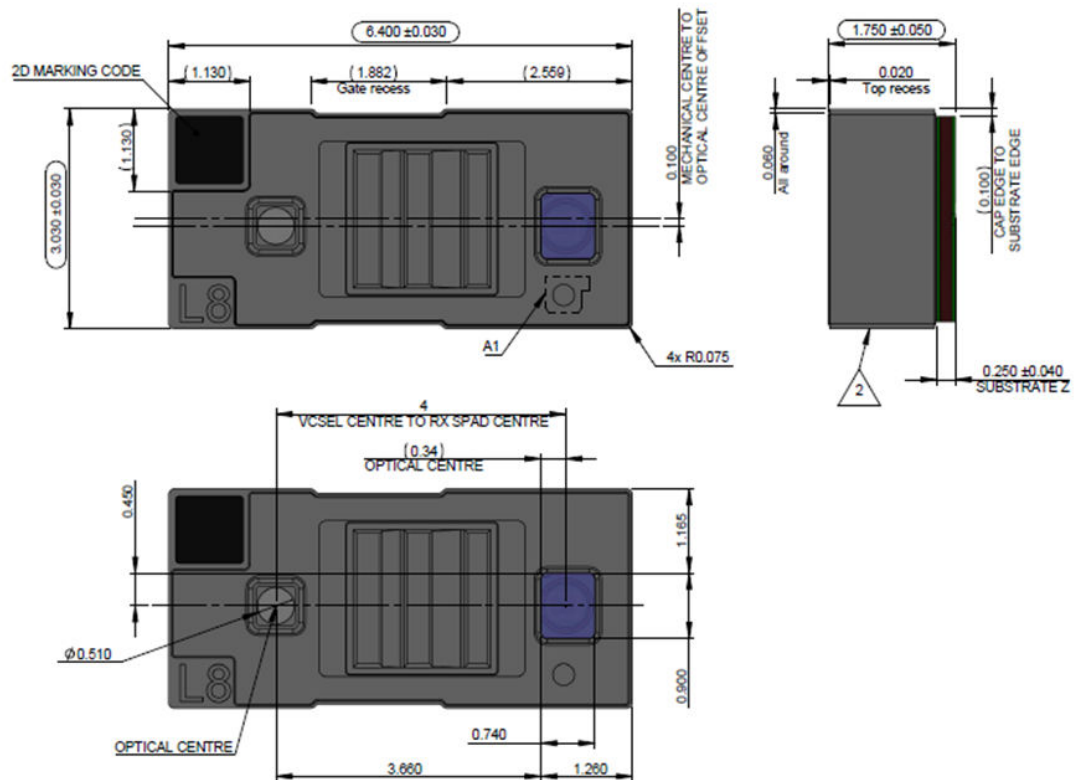

Note: SM stands for solder mask.

Note: A thermal pad is required on the application board for thermal dissipation. For more information, refer to AN5897.

Note: For more information, refer to the pin description in [Section 2.5: Device pinout](#).

Figure 30. Outline drawing (2/4)

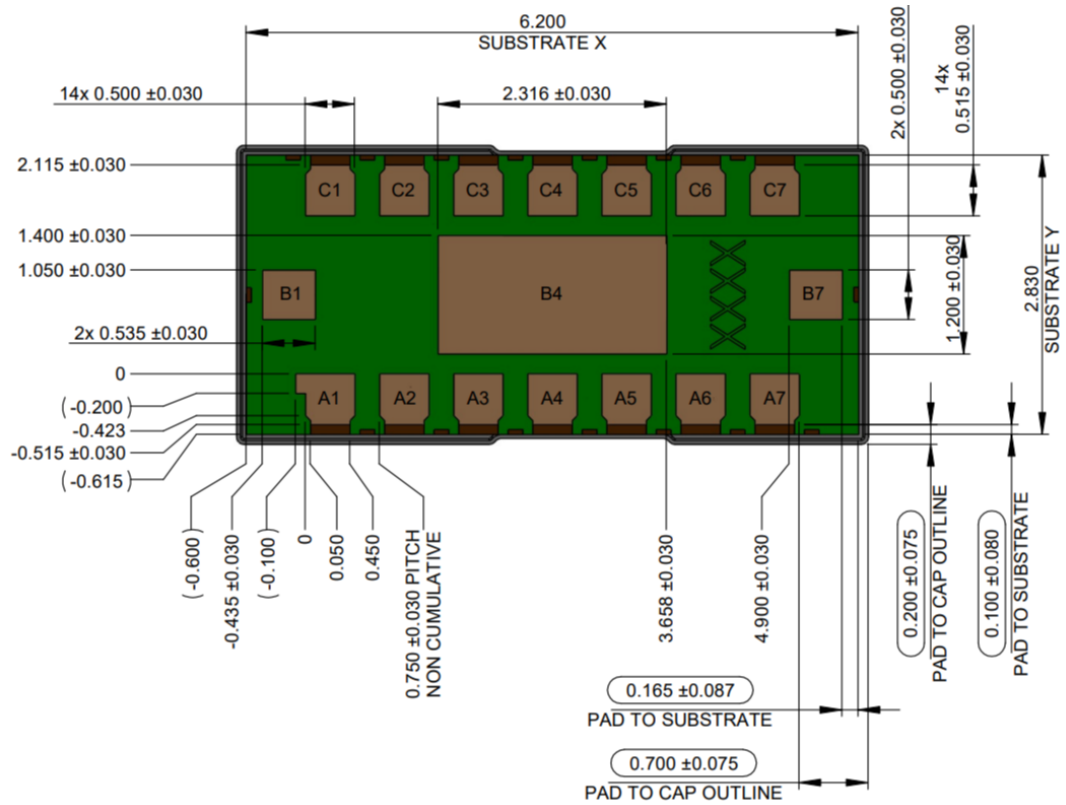

Note: For more information, refer to the pin description in Section 2.5: Device pinout.

Figure 31. Outline drawing (3/4) - option with liner

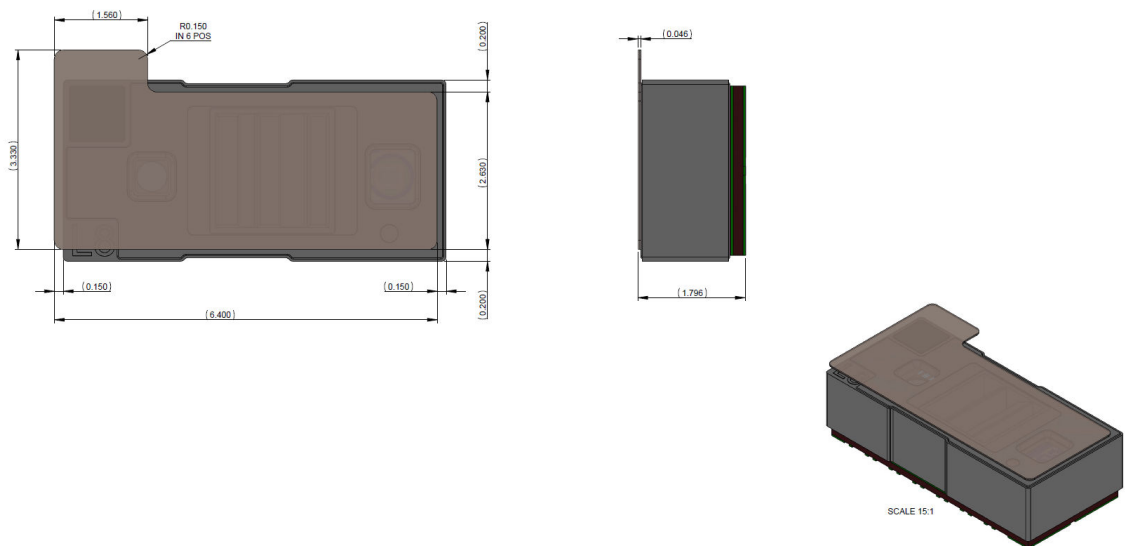

Caution: For sensors with the liner option, the liner must be removed during assembly of the customer device, just before mounting the cover glass. The liner is compliant with reflow at 260°C (as per JEDEC-STD-020E).

Figure 32. Outline drawing (4/4) - Exclusion cones

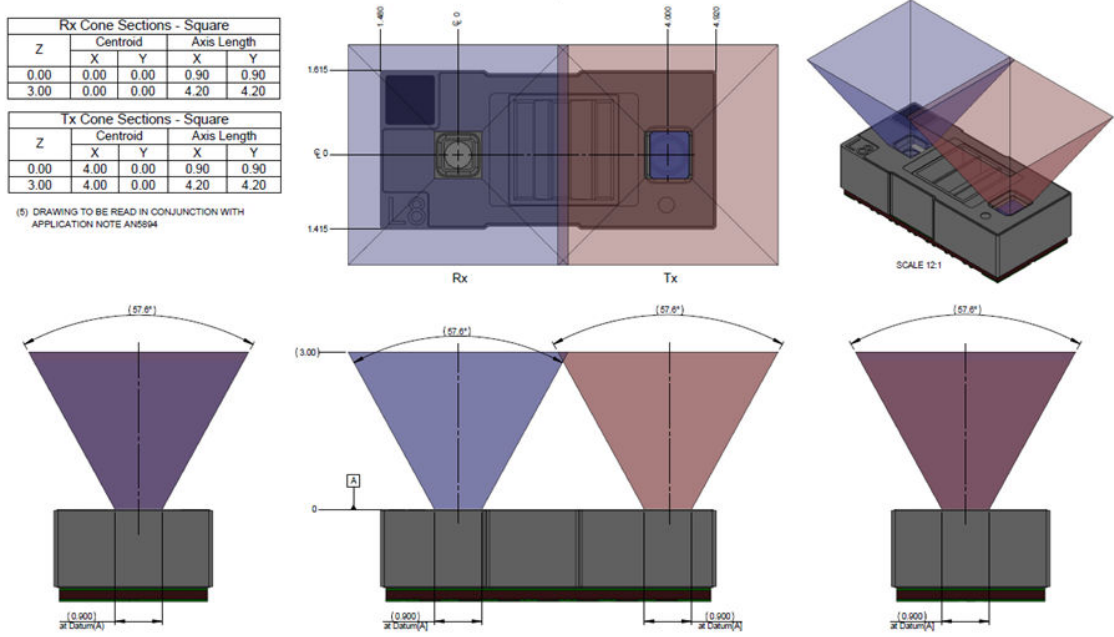

11 Laser safety considerations

The VL53L8CH contains a laser emitter and corresponding drive circuitry. The laser output is designed to meet Class 1 laser safety limits under all reasonably foreseeable conditions including single faults. This is in compliance with IEC 60825-1:2014.

Do not increase the laser output power by any means. Do not use any optics to focus the laser beam.

Caution: *Use of controls or adjustments, or performance of procedures other than those specified herein may result in hazardous radiation exposure.*

Figure 33. Class 1 laser label



The VL53L8CH complies with:

- IEC 60825-1:2014
- 21 CFR 1040.10 and 1040.11 except for conformance with IEC 60825-1:2014 as described in Laser Notice No.56, dated May 8, 2019
- EN 60825-1:2014 including EN 60825-1:2014/A11:2021,
- EN 50689:2021 except for the requirement of clause 5 from EN50689 regarding child appealing products. If designing a child appealing product, contact ST Technical Application Support.

12 Packing and labeling

12.1 Product marking

There are two types of product marking:

- The first is on the backside of the module as shown in Figure 30. Outline drawing (2/4).
- The second is on the corner of the module cap as shown in Figure 34 below.

Product marking on the backside of the module

This is a two-zone product marking. The first marking is the silicon product code. The second is the internal tracking code.

Product marking on the corner of the module cap

This is a 2D marking. Note that the code aligns with pin C7 of the module and is not an indicator of pin 1.

Figure 34. 2D marking product code on module cap



12.2 Inner box labeling

The labeling follows STMicroelectronics' standard packing acceptance specification. The following information is on the inner box label:

- Assembly site
- Sales type
- Quantity
- Trace code
- Marking
- Bulk ID number

12.3 Packing

At the customer/subcontractor level, it is recommended to mount the device in a clean environment. To help avoid any foreign material contamination at final assembly level, the modules are shipped in a tape and reel format.

12.4 Tape outline drawing

Figure 35. VL53L8CH tape and reel packaging drawing

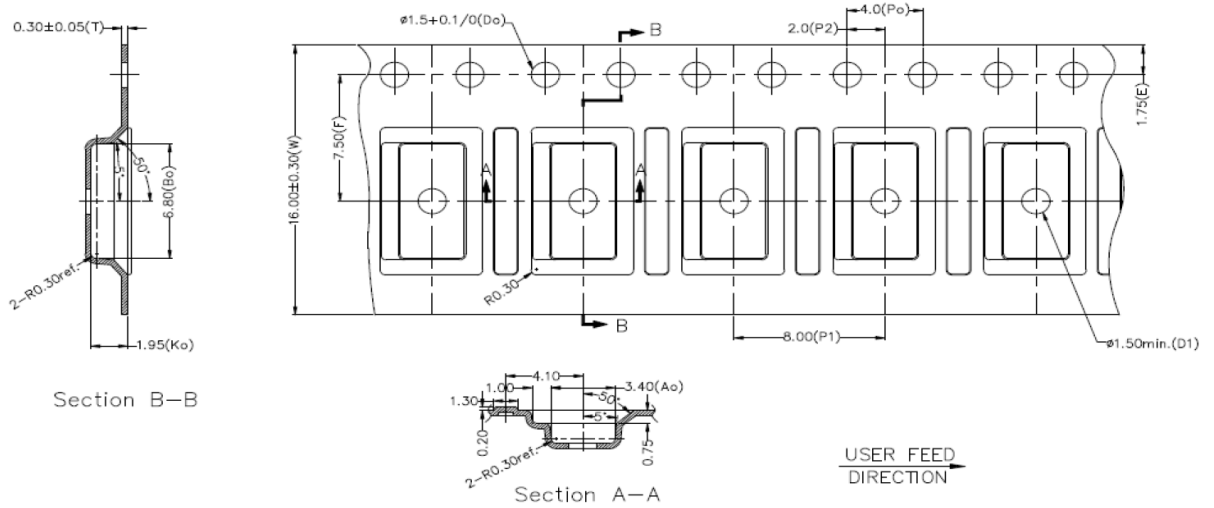

Caution: For sensors with the liner option, the liner must be removed during assembly of the customer device, just before mounting the cover glass. The liner is compliant with reflow at 260°C (as per JEDEC-STD-020E).

13 Handling, moisture, and reflow precautions

13.1 Recommended solder pad dimensions

Figure 36. Recommended solder pattern

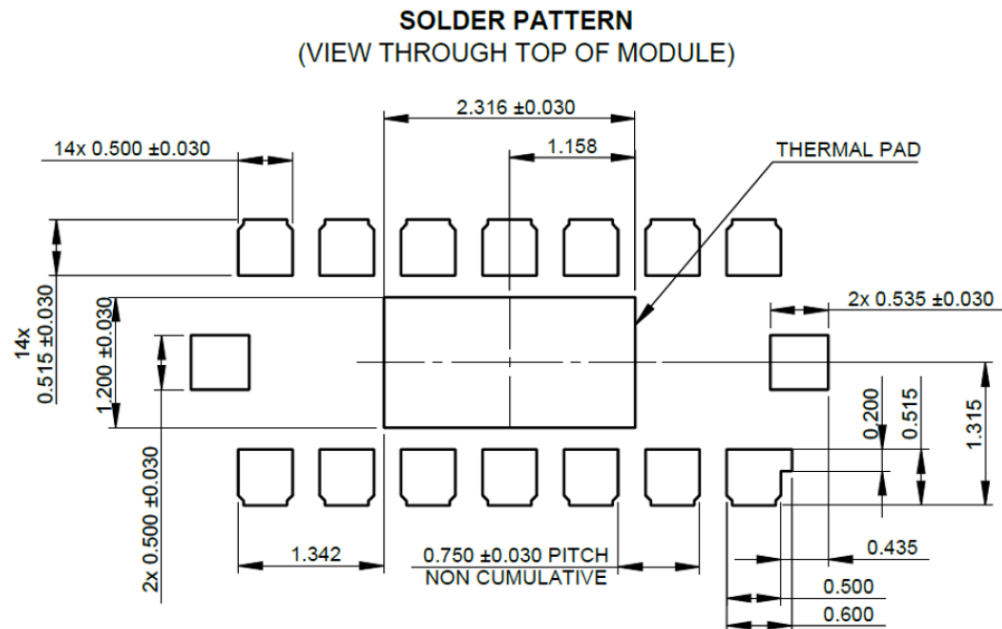

13.2 Shock precautions

Sensor modules house numerous internal components that are susceptible to shock damage. If a unit is subject to excessive shock, is dropped on the floor, or a tray/reel of units is dropped on the floor, it must be rejected, even if no apparent damage is visible.

13.3 Part handling

Handling must be done with nonmarring ESD safe carbon, plastic, or teflon tweezers. Ranging modules are susceptible to damage or contamination. The customer is advised to use a clean assembly process until a protective cover glass is mounted.

13.4 Compression force

A maximum compressive load of 25 N should be applied on the module.

13.5 Moisture sensitivity level

Moisture sensitivity is level 3 (MSL) as described in IPC/JEDEC JSTD-020-C.

For devices that are classified to the levels defined in JEDEC JSTD-020-C, JEDEC JSTD-033-C provides:

- Manufacturers and users with standardized methods for handling, packing, and shipping.
- Standardized methods for using moisture/reflow and process sensitive devices.

13.6 Pb-free solder reflow process

Table 27. Recommended solder profile and Figure 37. Solder profile show the recommended and maximum values for the solder profile.

Customers have to tune the reflow profile depending on the PCB, solder paste, and material used. We expect customers to follow the “recommended” reflow profile, which is specifically tuned for the VL53L8CH package.

For any reason, if a customer must perform a reflow profile, which is different from the “recommended” one (especially where the peak temperature is $> 240^{\circ}\text{C}$), the new profile must be qualified by the customer at their own risk. The profile has to be within the “maximum” profile limit described in Table 27. Recommended solder profile.

Table 27. Recommended solder profile

Parameters	Recommended	Maximum	Units
Minimum temperature (T_S min)	130	150	$^{\circ}\text{C}$
Maximum temperature (T_S max)	200	200	$^{\circ}\text{C}$
Time t_s (T_S min to T_S max)	90-110	60-120	s
Temperature (T_L)	217	217	$^{\circ}\text{C}$
Time (t_L)	55-65	55-65	s
Ramp up	2	3	$^{\circ}\text{C/s}$
Temperature (T_{p-10})	—	235	$^{\circ}\text{C}$
Time (t_{p-10})	—	10	s
Ramp up	—	3	$^{\circ}\text{C/s}$
Peak temperature (T_p)	240	260	$^{\circ}\text{C}$
Time to peak	300	300	s
Ramp down (peak to T_L)	-4	-6	$^{\circ}\text{C/s}$

Figure 37. Solder profile

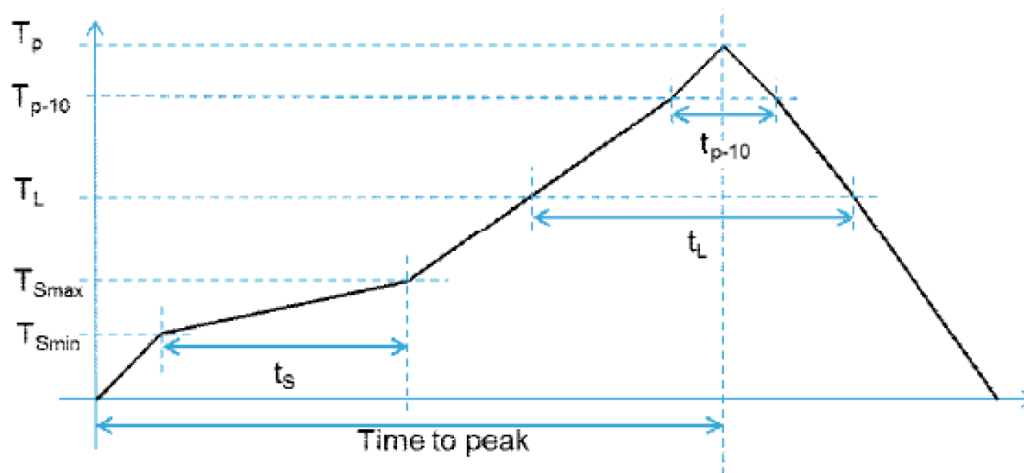

Note: The component should be limited to a maximum of three passes through this solder profile.

Note: As the VL53L8CH package is not sealed, only a dry reflow process should be used (such as convection reflow). Vapor phase reflow is not suitable for this type of optical component.

Note: The VL53L8CH is an optical component and as such, it should be treated carefully. This typically includes using a 'no-wash' assembly process.

14 Package information

To meet environmental requirements, ST offers these devices in different grades of **ECOPACK** packages, depending on their level of environmental compliance. ECOPACK specifications, grade definitions, and product status are available at: www.st.com. ECOPACK is an ST trademark.

15 Ordering information

The VL53L8CH is currently available in the format below. More detailed information is available on request.

Table 28. Order codes

Order codes	Package	Packing	Minimum order quantity
VL53L8CHV0GC/1	Optical LGA16 with liner	Tape and reel	3600 pcs
VL53L8CHV9GC/1	Optical LGA16 without liner	Tape and reel	3600 pcs

Revision history

Table 29. Document revision history

Date	Version	Changes
22-Jun-2023	1	Initial release
27-Jul-2023	2	Added Section 1: Acronyms and abbreviations. Updated Figure 6. Typical application schematic for SPI. Added Table 15. Example of typical power consumption in continuous mode. Added values to Table 16. Example of typical power consumption in autonomous mode.
08-Aug-2023	3	Updated signal descriptions for C1 and C2 pins in Table 3. VL53L8CH pin description for I ² C and SPI configuration.
09-Apr-2024	4	Updated the signal description for A2 pin in Table 3. VL53L8CH pin description for I ² C and SPI configuration. Modified the toggling pin name in the last note of Section 2.5: Device pinout. Updated Section 3.3: Power up sequence. Added a note at the end of Section 7.5: Digital input and output. Updated Section 10: Outline drawings. Updated Section 12.1: Product marking. Updated Section 12.3: Packing. Added optical LGA16 without liner to Section 15: Ordering information.
03-Sep-2024	5	Section 2.2: Field of view: Modified exclusion zone from 57.9° to 57.6° in image and table. Added Section 6: Thermal characteristics, including AMR with maximum at 125°C. Section 7.2: Recommended operating conditions: Removed ambient temperature data. Renamed Section 12: Packing and labeling Moved note from Section 12.3: Packing to Section 10: Outline drawings. Removed "Storage temperature and conditions". Renamed Section 13: Handling, moisture, and reflow precautions Section 13.5: Moisture sensitivity level: Updated with information regarding JEDEC JSTD-033-C.
05-Sep-2024	6	Updated document status.
03-Oct-2024	7	Table 3. VL53L8CH pin description for I ² C and SPI configuration: Modified signal name and description of pin A1 and B1. Table 8. SPI interface timing specification: Removed minimum value for <i>Operating frequency</i> . Updated Figure 30. Outline drawing (2/4).
03-Jun-2024	8	Updated naming

Contents

1	Acronyms and abbreviations	3
2	Product overview	4
2.1	Technical specifications	4
2.2	Field of view	4
2.3	Field of illumination	5
2.4	System block diagram	6
2.5	Device pinout	6
2.6	Application schematics	8
3	Functional description	10
3.1	Software interface	10
3.2	Power state machine	10
3.3	Power up sequence	11
4	I²C control interface	12
4.1	I ² C interface - timing characteristics	14
5	SPI timing specification	16
5.1	SPI write messages	17
5.2	SPI read messages	18
6	Thermal characteristics	19
6.1	Absolute maximum rating (T _{STG})	19
6.2	Ambient operating temperature	19
7	Electrical characteristics	20
7.1	Absolute maximum ratings	20
7.2	Recommended operating conditions	20
7.3	Electrostatic discharge (ESD)	20
7.4	Current consumption	21
7.5	Digital input and output	22
8	Histogram (CNH) output	23
9	Ranging performances	25
9.1	Zone mapping	25
9.1.1	Zone mapping 4x4	25
9.1.2	Zone mapping 8x8	25
9.1.3	Effective zone orientation	26
9.2	Continuous ranging mode	26
9.2.1	Measurement conditions	26

9.2.2	Maximum ranging distance 4x4	27
9.2.3	Maximum ranging distance 8x8	27
9.2.4	Range accuracy in continuous mode	28
9.3	Autonomous ranging mode	29
9.3.1	Measurement conditions	29
9.3.2	Maximum ranging distance 4x4	29
9.3.3	Maximum ranging distance 8x8	30
9.3.4	Range accuracy in autonomous mode	31
9.4	Range offset drift over temperature	31
10	Outline drawings	33
11	Laser safety considerations	36
12	Packing and labeling	37
12.1	Product marking	37
12.2	Inner box labeling	37
12.3	Packing	37
12.4	Tape outline drawing	38
13	Handling, moisture, and reflow precautions	39
13.1	Recommended solder pad dimensions	39
13.2	Shock precautions	39
13.3	Part handling	39
13.4	Compression force	39
13.5	Moisture sensitivity level	39
13.6	Pb-free solder reflow process	40
14	Package information	41
15	Ordering information	42
	Revision history	43

IMPORTANT NOTICE – READ CAREFULLY

STMicroelectronics NV and its subsidiaries (“ST”) reserve the right to make changes, corrections, enhancements, modifications, and improvements to ST products and/or to this document at any time without notice. Purchasers should obtain the latest relevant information on ST products before placing orders. ST products are sold pursuant to ST’s terms and conditions of sale in place at the time of order acknowledgment.

Purchasers are solely responsible for the choice, selection, and use of ST products and ST assumes no liability for application assistance or the design of purchasers’ products.

No license, express or implied, to any intellectual property right is granted by ST herein.

Resale of ST products with provisions different from the information set forth herein shall void any warranty granted by ST for such product.

ST and the ST logo are trademarks of ST. For additional information about ST trademarks, refer to www.st.com/trademarks. All other product or service names are the property of their respective owners.

Information in this document supersedes and replaces information previously supplied in any prior versions of this document.

© 2025 STMicroelectronics – All rights reserved