

BMA280

Digital, triaxial acceleration sensor

Bosch Sensortec



BOSCH
Invented for life

General Description

The BMA280 is an advanced, ultra-small, triaxial, low-g acceleration sensor with digital interfaces, aiming for low-power consumer electronics applications. Featuring 14 bit digital resolution, the BMA280 allows very low-noise measurement of accelerations in 3 perpendicular axes and thus senses tilt, motion, shock and vibration in cellular phones, handhelds, computer peripherals, man-machine interfaces, virtual reality features and game controllers.

BMA280 target applications

- ▶ Spirit level
- ▶ Navigation
- ▶ Display profile switching (portrait/landscape, face-up/face-down switching)
- ▶ Flat detection
- ▶ Tap / double tap sensing
- ▶ Menu scrolling, gaming
- ▶ Advanced power management for mobile devices
- ▶ Shock and free-fall detection
- ▶ Step-counting
- ▶ Tilt compensation for electronic compass

Sensor features

With its small footprint of only 2 mm x 2 mm the BMA280 is unique in the class of low-noise, 14 bit digital acceleration sensors. On top, the BMA280 integrates a multitude of features that facilitate its use especially in the area of motion detection applications, such as device orientation detection, gaming, HMI and menu browser control. Navigation and spirit level measurement applications are enabled by the 14 bit resolution.

Featuring a full operation current consumption of only 130 μ A the BMA280 is ideally suited for mobile consumer electronic devices. In low-power mode operation the current consumption can be even further reduced by more than one order of

| BMA280 | Technical data |
|---|--|
| Digital resolution | 14 bit |
| Resolution (in ± 2 g range) | 0.244 mg |
| Measurement ranges (programmable) | ± 2 g, ± 4 g, ± 8 g, ± 16 g |
| Sensitivity (calibrated) | ± 2 g: 4096 LSB/g ± 4 g: 2048 LSB/g ± 8 g: 1024 LSB/g ± 16 g: 512 LSB/g |
| Zero-g offset (typ., over life-time) | ± 50 mg |
| Noise density (typ.) | 120 μ g/ $\sqrt{\text{Hz}}$ |
| Bandwidths (programmable) | 500 Hz ... 8 Hz |
| Digital inputs/outputs | SPI & I ² C, 2x digital interrupt pins |
| Supply voltage (V _{DD}) | 1.62 ... 3.6 V |
| I/O supply voltage (V _{DDIO}) | 1.2 ... 3.6 V |
| Temperature range | -40 ... +85°C |
| Current consumption | |
| ▶ full operation | 130 μ A (@2kHz data rate) |
| ▶ low-power mode | 6.5 μ A (@40Hz data rate) |
| FIFO data buffer | 32 sample depth (for each axis) |
| LGA package | 2 x 2 x 0.95 mm ³ |
| Shock resistance | 10,000 g x 200 μ s |

magnitude. The BMA280 is highly configurable in order to give the designer full flexibility when integrating the sensor into the system.

Sensor operation

The BMA280 supports two modes of operation:
1) Standard data polling mode: Acceleration data is directly read-out via the sensor's digital interface and computed by a system μ Controller, application processor or a base-band processor.

2) Interrupt engine mode: Acceleration data is computed already within the BMA280 by the integrated, programmable interrupt engine. Depending on the programmable settings the integrated interrupt engine of the BMA280 signals the occurrence of certain events via the sensors' two interrupt pins. The corresponding registers of the BMA280 can easily be set and read-out via the digital sensor interface.

The BMA280 features I²C and SPI (3-wire/4-wire) digital, serial interfaces. Sensor parameters, like g-ranges or low-pass filter settings, and also all interrupt engine settings can be easily programmed via the digital interfaces.

Integrated interrupt engine

One of the key elements of the BMA280 is the enhanced intelligent interrupt engine that gives the hard and software designer full control. Various motion detection scenarios can be identified by the BMA280 and signaled to the system via two interrupt pins. The interrupt sources can be freely mapped to either of the two interrupt pins. The following motion detection use case scenarios are supported by the BMA280 interrupt engine:

- ▶ Data-ready (e.g. for processor synchronization)
- ▶ Any-motion (slope) detection (e.g. for wake-up)
- ▶ Tap sensing (e.g. for tap-sensitive UI control)
- ▶ Orientation change recognition (e.g. for portrait/landscape switching)
- ▶ Flat detection (e.g. for position sensitive switching)
- ▶ Low-g / high-g detection (e.g. for shock and free-fall detection)
- ▶ No-motion (e.g. for power saving)

Interrupt parameters (e.g. switching angles and hysteresis settings for orientation change) can be configured by the designer and thus perfectly support the integration of the BMA280 into the user's system environment.

System compatibility

The BMA280 has been designed for best possible fit into modern mobile consumer electronics devices. Besides the ultra-small footprint and lowest power consumption, the BMA280 has very wide ranges for V_{DD} and V_{DDIO} supply voltages. The BMA280 also includes a FIFO buffer with 32 samples depth for each

acceleration axis. An integrated self-test feature facilitates overall system reliability.

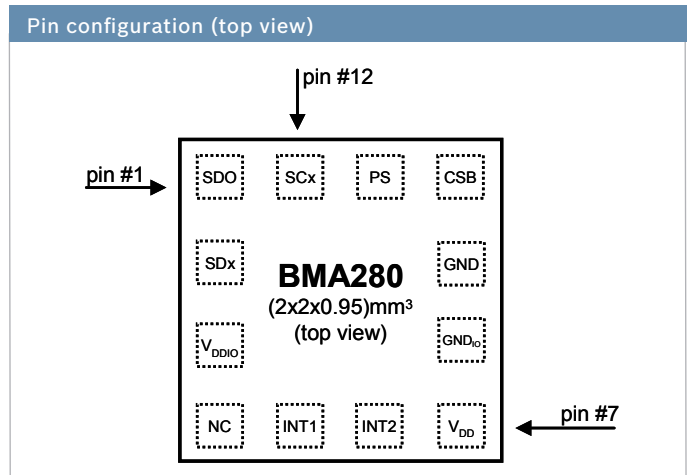

| Pin | Name | Description |
|-----|-------------------|--|
| 1 | SDO | SPI: serial data output in SPI 4-wire mode I ² C: I ² C address select |
| 2 | SDx | SPI: SDI serial data input in SPI 4-wire mode SPI: SDA serial data I/O in SPI 3-wire mode I ² C: SDA serial data line |
| 3 | V _{DDIO} | Voltage supply for I/Os |
| 4 | NC | Not connected |
| 5 | INT1 | Interrupt output #1 |
| 6 | INT2 | Interrupt output #2 |
| 7 | V _{DD} | Voltage supply |
| 8 | GND _{IO} | Ground for I/O |
| 9 | GND | Ground |
| 10 | CSB | Chip select for SPI |
| 11 | PS | Protocol select: SPI: GND I ² C: V _{DDIO} |
| 12 | SCx | SCK: SPI clock SCL: I ² C clock |

**Headquarters
Bosch Sensortec GmbH**

Gerhard-Kindler-Strasse 8
72770 Reutlingen · Germany
Telephone +49 7121 3535 900
Fax +49 7121 3535 909
contact@bosch-sensortec.com
www.bosch-sensortec.com