

RYS3520

+3.3V UART interface GNSS module

Datasheet



PRODUCT DESCRIPTION

The RYS3520 +3.3V GNSS module is a multi-GNSS module with high sensitivity and performance, It supports GPS, GLONASS, Galileo, BeiDou and QZSS systems. It also supports SBAS, WAAS, EGNOS, MSAS and GAGAN and AGNSS functions.

FEATURES

- Multi-GNSS GPS/GLONASS/Galileo/BeiDou module.
- Protocol NMEA 0183 V4.10.
- Support for multi-GNSS including QZSS and SBAS ranging.
- Integrated 12 multi-tone active interference cancellers.
- Indoor and outdoor path detection and compensation.
- Including enhanced SAW filter, LNA and TCXO.

BLOCK DIAGRAM

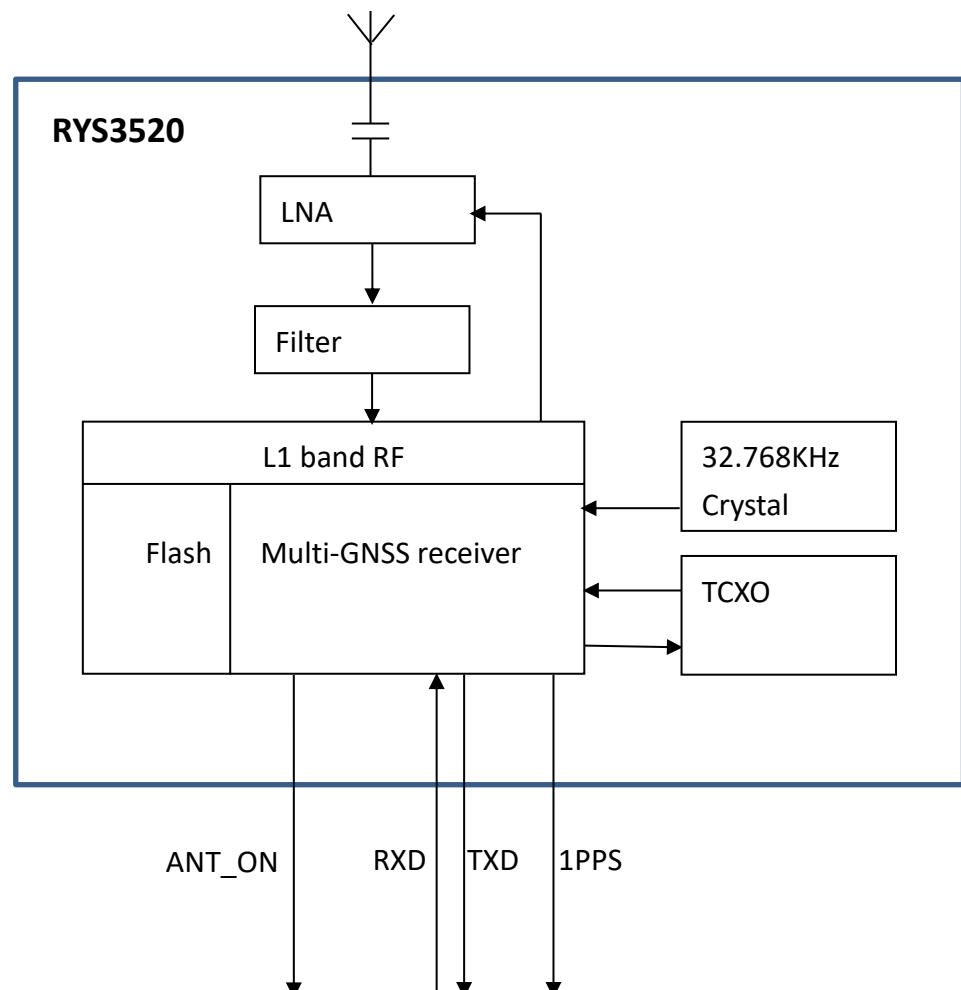

PIN DESCRIPTION

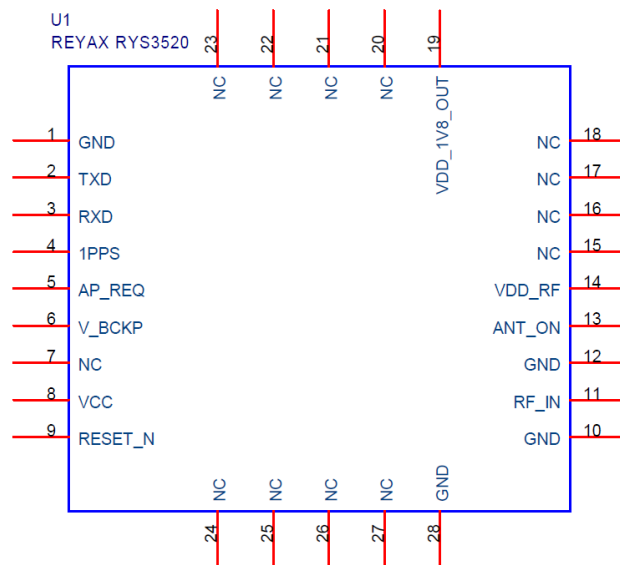

Pin	Name	I/O	Condition
1	GND	-	Ground
2	TXD	O	Serial interface Output.
3	RXD	I	Serial interface Input.
4	1PPS	O	Time pulse output.
5	AP_REQ	I	Keep it low before sending any command to ensure the command can be sent successfully.
6	V_BCKP	I	Backup voltage supply.
7	NC	-	Leave Unconnected.
8	VCC	I	Power Supply and I/O Voltage.
9	RESET_N	I	Pull down at least 100ms to reset the module.
10	GND	-	Ground
11	RF_IN	I	GNSS signal input.
12	GND	-	Ground
13	ANT_ON	O	Power control for external LNA.
14	VDD_RF	O	Supplies power for external RF components.
15	NC	-	Leave Unconnected.
16	NC	-	Leave Unconnected.
17	NC	-	Leave Unconnected.

18	NC	-	Leave Unconnected.
19	VCC_1V8_OUT	O	1.8V power supply output.
20	NC	-	Leave Unconnected.
21	NC	-	Leave Unconnected.
22	NC	-	Leave Unconnected.
23	NC	-	Leave Unconnected.
24	NC	-	Leave Unconnected.
25	NC	-	Leave Unconnected.
26	NC	-	Leave Unconnected.
27	NC	-	Leave Unconnected.
28	GND	-	Ground

APPLICATION SCHEMATIC (UART Interface)

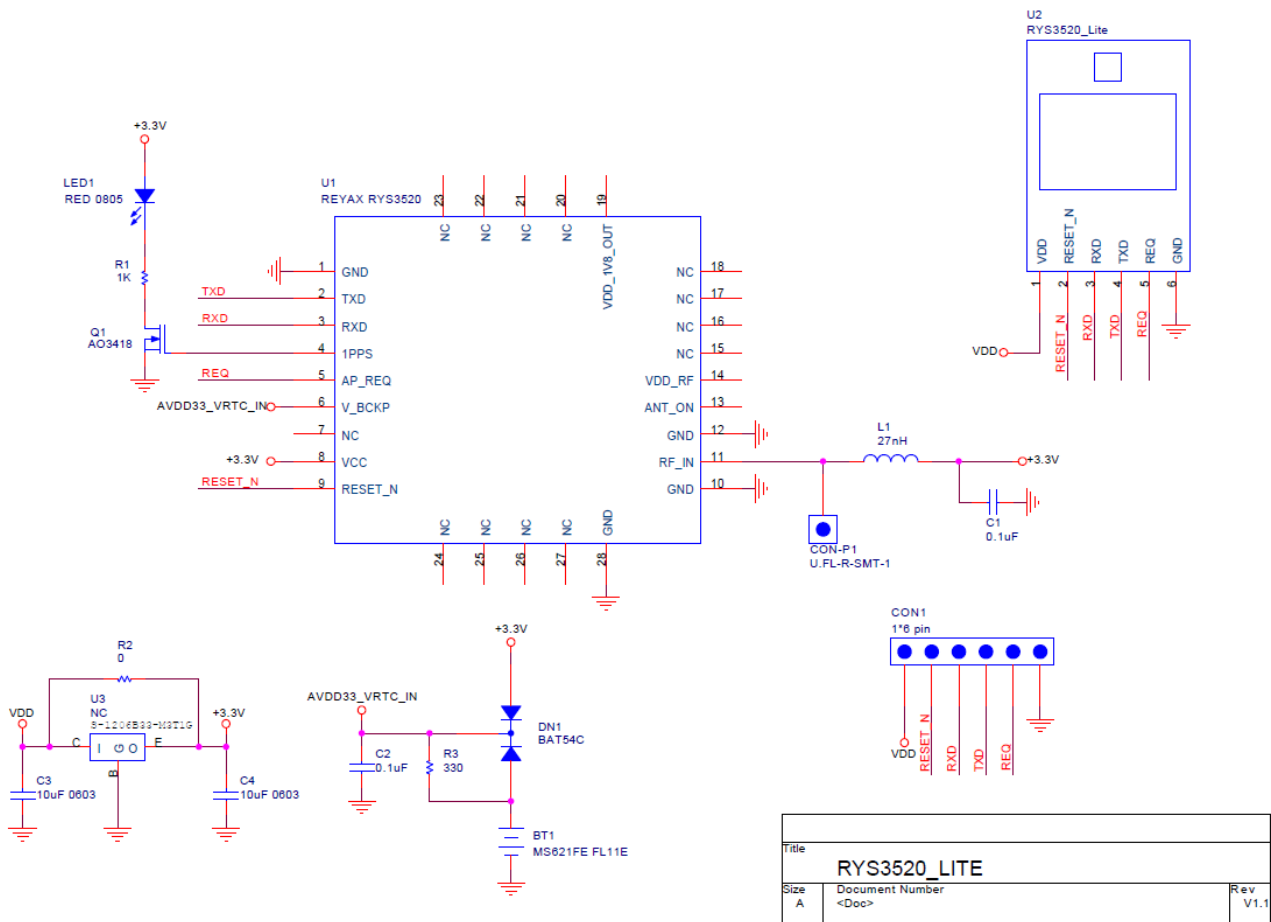

SPECIFICATION

Item	Min.	Typical	Max.	Unit	Condition
Power Supply Voltage	2.5	3.3	3.63	V	VCC
Backup Supply Voltage	1.65	3.3	3.63	V	V_BCKP
Satellite acquisition Current		33		mA	passive antenna
Satellite tracking Current		33		mA	passive antenna
RTC backup Current		12		uA	
Default Baud Rate		115200		bps	8,N,1
Digital input level high	2		VCC+0.3	V	VIH
Digital input level low	-0.3		0.8	V	VIL
Digital output level high	2.4		VCC	V	VOH
Digital output level low			0.4	V	VOL
Supported GNSS Bands				MHz	GPS L1 C/A, QZSS L1 C/A: 1575.42 MHz GLONASS L1: 1598.0625–1605.375 MHz BDS B1I: 1561.098 MHz B1C*: 1575.42 MHz Galileo E1: 1575.42 MHz
Number of Tracking Channels		47			
Number of Concurrent GNSS		5			
Acceleration			4	G	
Accuracy of 1PPS Signal		100		ns	
Navigation update rate		1	10	Hz	
Accuracy		1.5		M	CEP 50%, 24 hours static, more than 6 satellites, Signal strength is -130dBm
Cold starts without AGNSS		26		Sec.	Signal strength is -130dBm
Warm starts without AGNSS		20		Sec.	Signal strength is -130dBm
Hot starts without AGNSS		1		Sec.	Signal strength is -130dBm
Cold starts with EASY®		12		Sec.	Signal strength is -130dBm
Warm starts with EASY®		2		Sec.	Signal strength is -130dBm
Hot starts with EASY®		1		Sec.	Signal strength is -130dBm
Cold starts with Flash EPO®		5		Sec.	Signal strength is -130dBm
Tracking Sensitivity		-167		dBm	
Hot starts Sensitivity		-160		dBm	
Cold starts Sensitivity		-148		dBm	
Velocity			500	M/s	

Altitude		10000	80000[1]	M	[1]Balloon mode
Acceleration		4		G	
Operating Temperature	-40	25	+85	°C	
Dimensions					10.1mm*9.7mm*2.3mm
Weight		0.5		gram	

REFLOW SOLDERING

Consider the "IPC-7530 Guidelines for temperature profiling for mass soldering (reflow and wave) processes, published 2001. **Only single reflow soldering processes are recommended for REYAX modules. Repeated reflow soldering processes and soldering the module upside down are not recommended.**

Preheat phase

Initial heating of component leads and balls. Residual humidity will be dried out. Please note that this preheat phase will not replace prior baking procedures.

- Temperature rise rate: max. 3 °C/s If the temperature rise is too rapid in the preheat phase it may cause excessive slumping.
- Time: 60 - 120 s If the preheat is insufficient, rather large solder balls tend to be generated. Conversely, if performed excessively, fine balls and large balls will be generated in clusters.
- End Temperature: 150 - 200 °C If the temperature is too low, non-melting tends to be caused in areas containing large heat capacity.

Heating/ Reflow phase

The temperature rises above the liquidus temperature of 217°C. Avoid a sudden rise in temperature as the slump of the paste could become worse.

- Limit time above 217 °C liquidus temperature: 40 - 60 s
- Peak reflow temperature: 245 °C

Cooling phase

A controlled cooling avoids negative metallurgical effects (solder becomes more brittle) of the solder and possible mechanical tensions in the products. Controlled cooling helps to achieve bright solder fillets with a good shape and low contact angle.

- Temperature fall rate: max 4 °C/s To avoid falling off, the REYAX module should be placed on the topside of the motherboard during soldering.

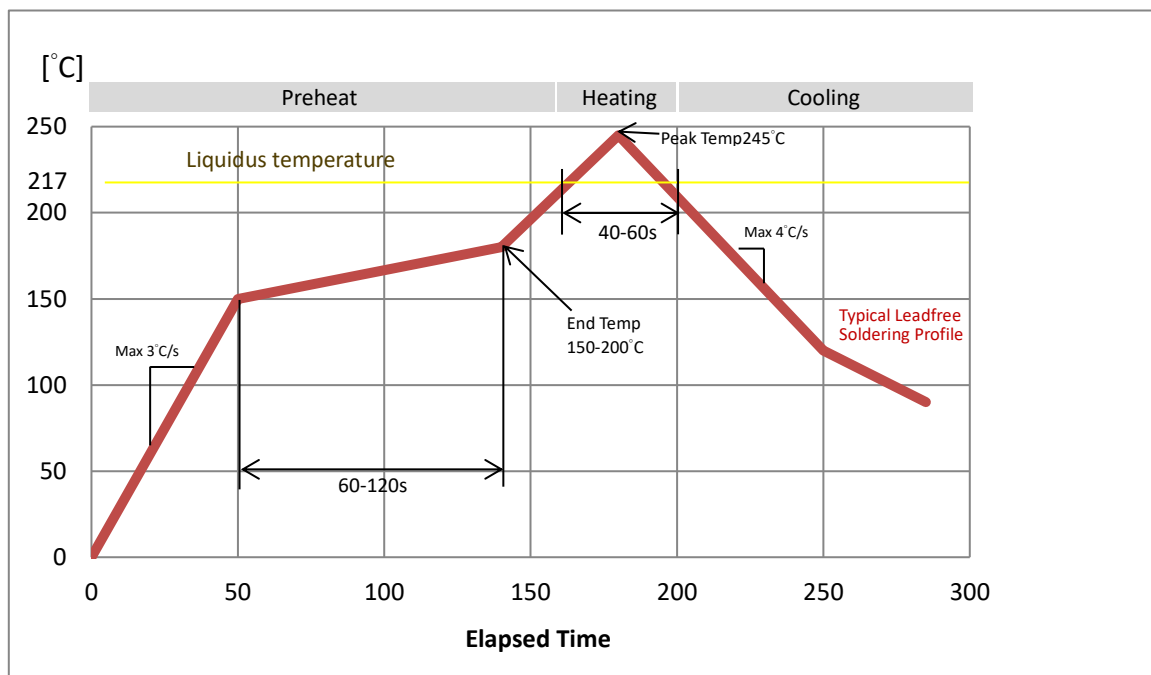

Recommended soldering profile

DIMENSIONS

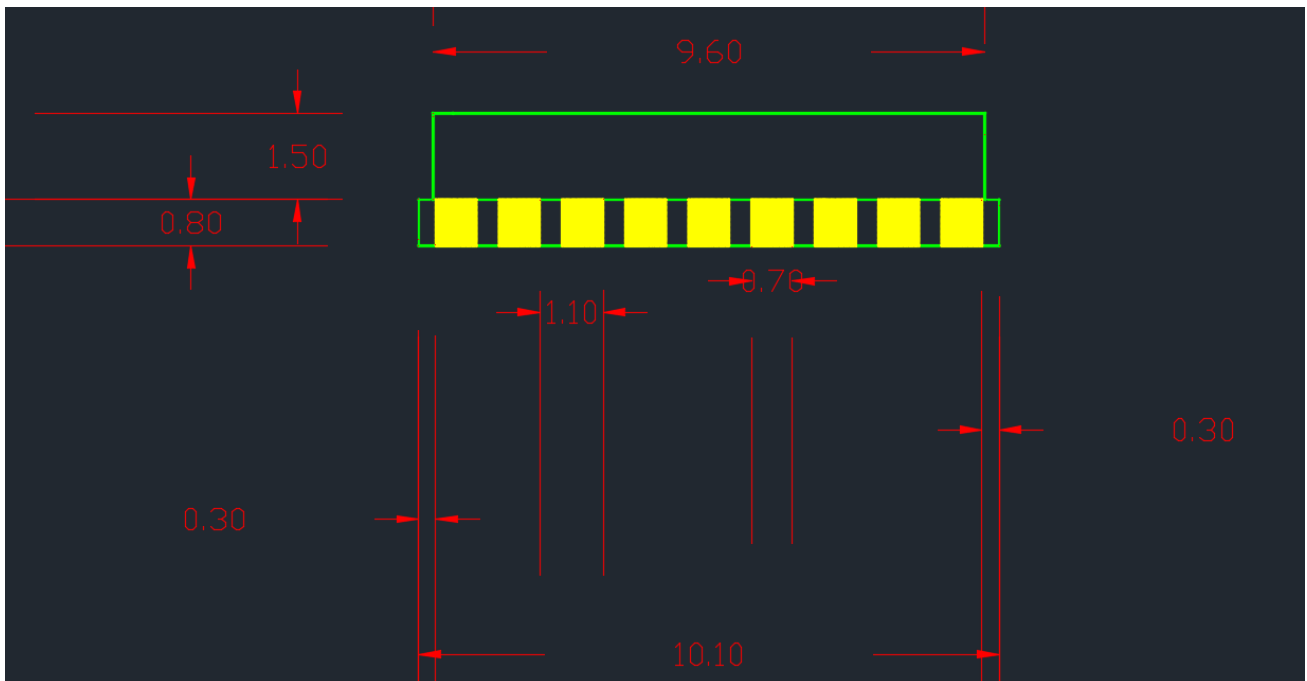
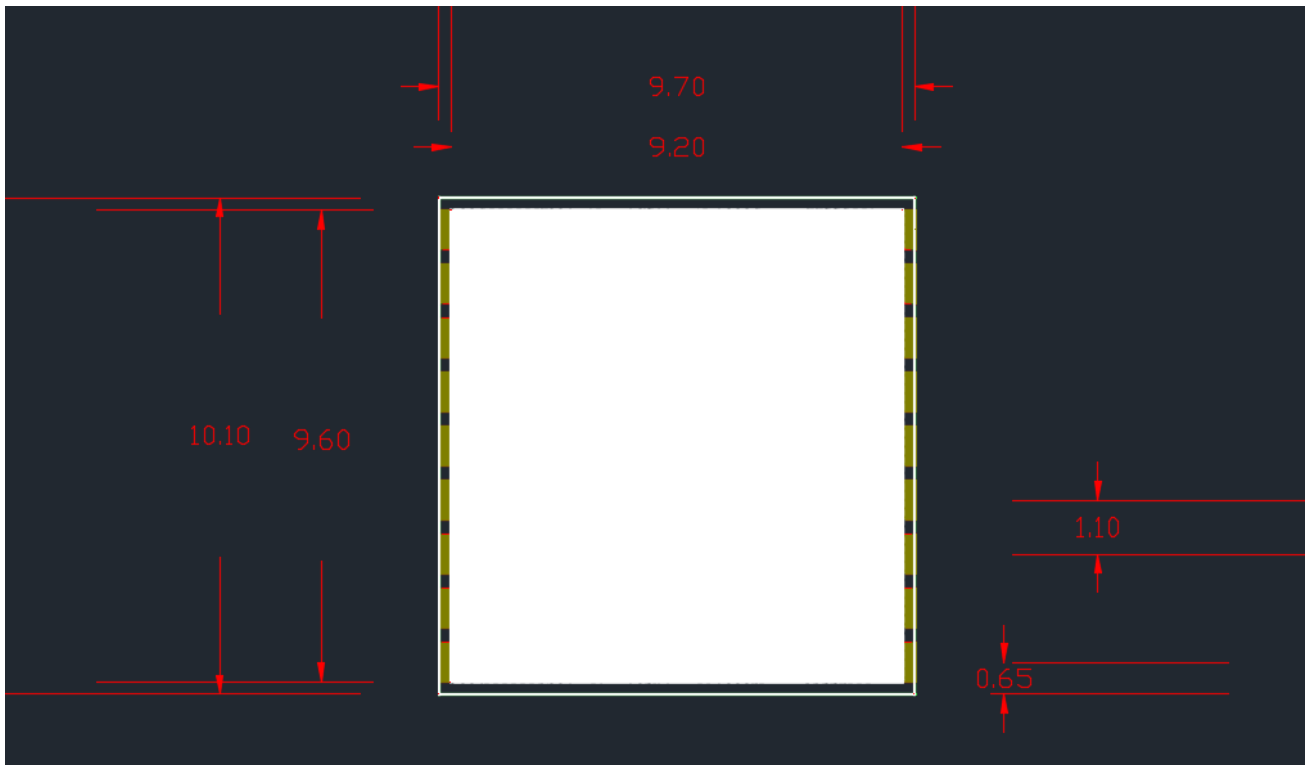

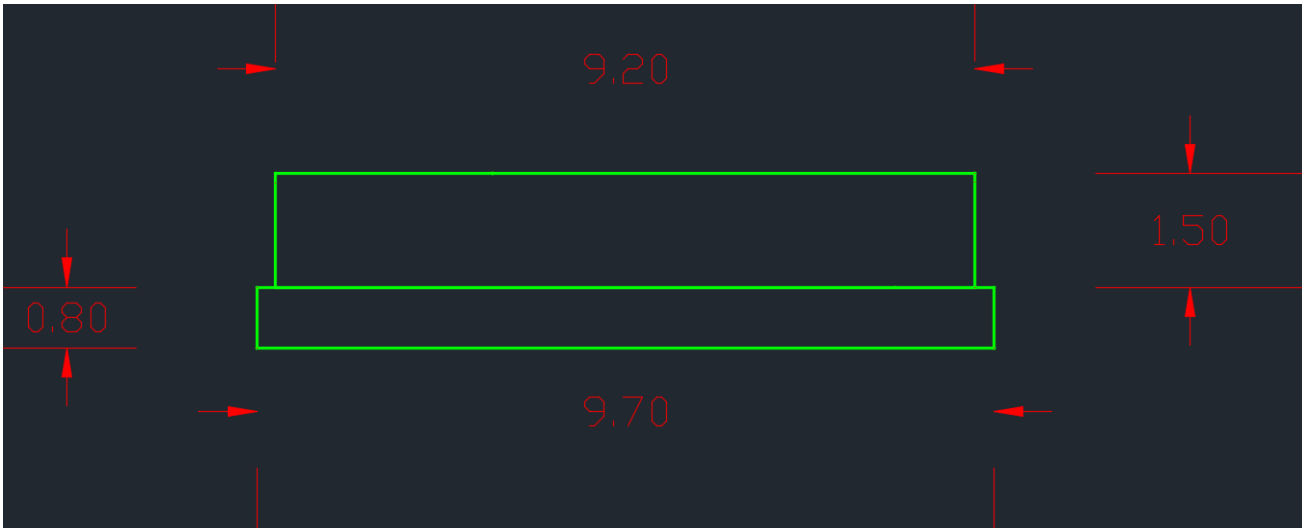

LAYOUT FOOTPRINT RECOMMENDATIONS

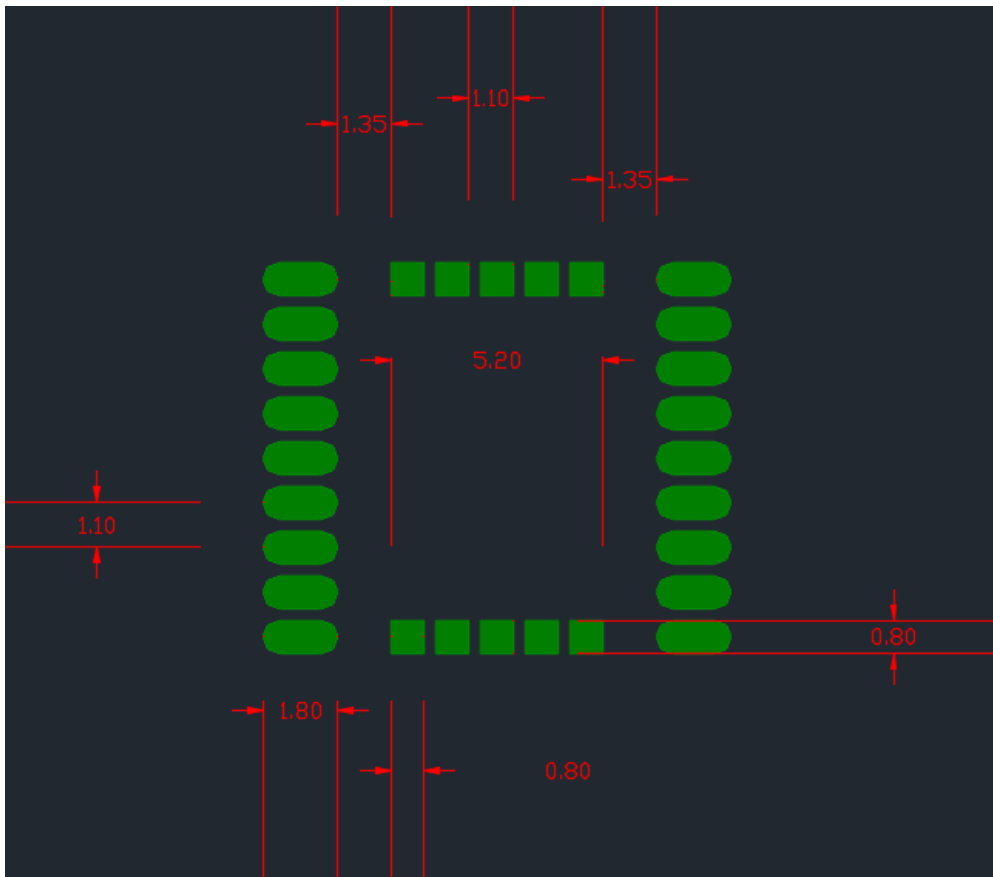

Unit : mm

REYAX
TECHNOLOGY CORPORATION, LTD

E-mail : sales@reyax.com

Website : <https://reyax.com>