

Applications

- LTE Handsets, Data Cards & Mobile Routers
- Band 13
777 – 787 MHz Uplink
746 – 756 MHz Downlink

Product Features

- NoDrift™ SAW Technology With Near Zero TCF
- Low Insertion Loss
- High Isolation
- Single-Ended (SE) 50 Ω Receive & Transmit Ports
- RoHS Compliant, Pb-Free Module Package

General Description

The TQQ1013 is a high-performance NoDrift™ Surface Acoustic Wave duplexer designed to meet the strict band 13 NS07 rejection requirements mitigating signal migration in the public safety frequency band.

The TQQ1013 is specifically designed to meet the high performance expectations of insertion loss, rejection, isolation, and linearity for LTE systems applications under all operating conditions.

The TQQ1013 uses common module packaging techniques to achieve the industry standard 2.5 x 2.0 x 0.9 mm footprint. This duplexer exhibits excellent power handling capabilities.

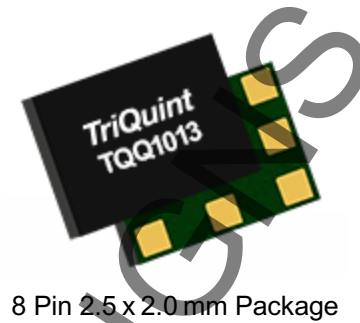

8 Pin 2.5 x 2.0 mm Package

Functional Block Diagram

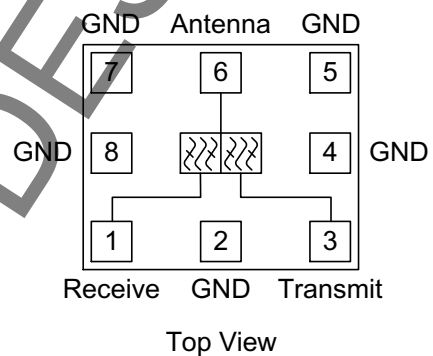

Pin Configuration

Pin #	Label
1	Receive
3	Transmit
6	Antenna
2, 4, 5, 7, 8	GND (Ground)
Backside Center Pad 9	GND (Ground)

Ordering Information

Part No.	Description
TQQ1013TR7	B13 Duplexer
TQQ1013-EVB	Evaluation Board

Standard T/R size = 2500 pieces on a 7" reel.

Absolute Maximum Ratings

Parameter	Rating
Storage Temperature	-40 to +90 °C
Peak Power rating for a max of 200 msec at +90 °C	+35 dBm

Operation of this device outside the parameter ranges given above may cause permanent damage.

Recommended Operating Conditions

Parameter	Min	Typ	Max	Units
T _{CASE}	-20		+90	°C

The duplexer will function over the recommended range without degradation in reliability or permanent change in performance.

Electrical Specifications: Antenna to Transmit^(1, 2, 3)

Unless Otherwise Noted: Operating Temp = -20 °C to +90 °C

Parameter	Conditions	Min	Typ	Max	Units
Frequency		777.5	-	786.5	MHz
Insertion Loss ⁽⁵⁾	777.5 – 786.5 MHz	-	2.2	3.5	dB
Amplitude Variation ⁽⁴⁾ (over any 5 MHz in-band)	777.5 – 786.5 MHz	-	1.1	2.1	dB p-p
	728 – 746 MHz	35	48	-	dB
	746 – 756 MHz	46	50	-	
	758 – 768 MHz	35	40	-	
	793 – 805 MHz	20	30	-	
	869 – 894 MHz	44	45	-	
	1554 – 1565 MHz	45	50	-	
	1565 – 1607 MHz	45	50	-	
	1805 – 1880 MHz	30	45	-	
	1930 – 1990 MHz	30	45	-	
	2110 – 5950 MHz	20	30	-	
2400 – 2484 MHz	54	57	-		
5170 – 5850 MHz	28	33	-		
Attenuation (NS07) ⁽⁶⁾	768 – 775 MHz	22	-	-	dB
VSWR at antenna	777.5 – 786.5 MHz	-	1.7:1	1.8:1	
VSWR at TX port	777.5 – 786.5 MHz	-	1.5:1	2.0:1	
Antenna Impedance (single-ended)		-	50	-	Ohms
TX Impedance (single-ended)		-	50	-	Ohms
Input Power	CW tone at 50 °C	+29 dBm (0.8 W) > 5000 h			

Notes:

- In production devices will be tested at room temperature to a guardbanded specification to ensure electrical compliance over temperature.
- Electrical margin has been built into the design to account for the variations due to temperature drift and manufacturing tolerances.
- Typical values are based on average measurements at room temperature.
- Amplitude variation/ripple is defined as the difference between the lowest loss and the highest loss within defined frequency points.
- Integrated over 1RB
- Relative to integrated insertion loss in 777.5 – 786.5MHz over 1RB

Electrical Specifications: Antenna to Receive ^(1, 2, 3)

Unless Otherwise Noted: Operating Temp = -20 °C to +90 °C

Parameter	Conditions	Min	Typ	Max	Units
Frequency		746	-	756	MHz
Insertion loss	746 – 756 MHz	-	2.1	2.7	dB
Amplitude variation ⁽⁴⁾ (over any 5 MHz in-band)	746 – 756 MHz	-	0.4	1.0	dB p-p
Attenuation	771 – 772 MHz ⁽⁷⁾	18	22	-	dB
	771 – 772 MHz	10	22	-	
	777 – 787 MHz	54	58	-	
	1 – 686 MHz	40	44	-	
	686 – 728 MHz	25	30	-	
	2400 – 2500 MHz	40	55	-	
	4900 – 5162 MHz	20	25	-	
	5162 – 5950 MHz	12	15	-	
	6714 – 6804 MHz	15	18	-	
VSWR at antenna	746 – 756 MHz	-	1.7:1	1.8:1	
VSWR at RX port	746 – 756 MHz	-	1.6:1	1.8:1	
Antenna Impedance (single-ended)		-	50	-	Ohms
Load Impedance (single-ended)		-	50//47nH	-	Ohms

Notes:

1. In production devices will be tested at room temperature to a guardbanded specification to ensure electrical compliance over temperature.
2. Electrical margin has been built into the design to account for the variations due to temperature drift and manufacturing tolerances.
3. Typical values are based on average measurements at room temperature.
4. Amplitude variation/ripple is defined as the difference between the lowest loss and the highest loss within defined frequency points.
5. Integrated over 1RB
6. Relative to integrated insertion loss in 777.5 – 786.5 MHz over 1RB
7. At room temperature (+25 °C)

Electrical Specifications: Transmit to Receive

Parameter	Conditions	Min	Typ	Max	Units
Tx to Rx Isolation	746 – 749 MHz	51	52	-	dB
	749 – 752 MHz	52	53	-	
	752 – 756 MHz	53	54	-	
	777 – 787 MHz	55	58	-	

Application Drawing

Schematic

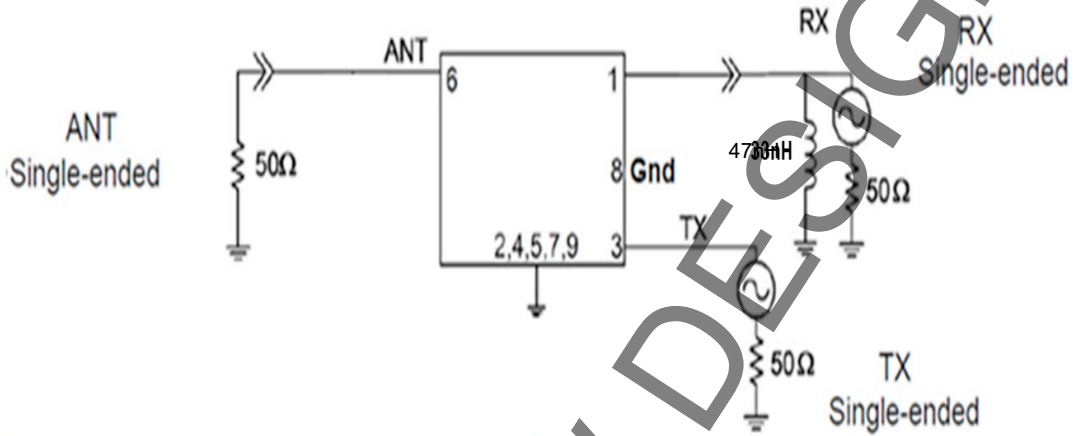

Notes:

- 1. DC blocking required before pin 3 Tx.

Receive Performance Plots

Unless Otherwise Noted: Operating Temp = -25 °C

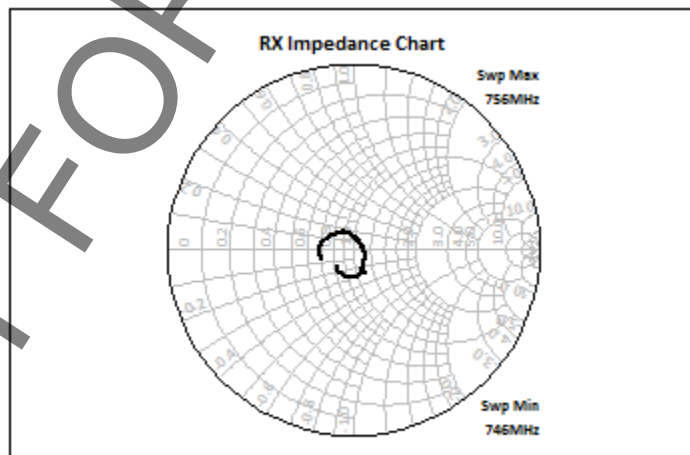
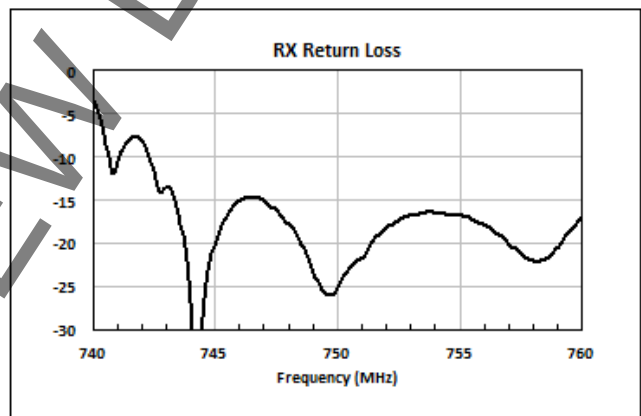
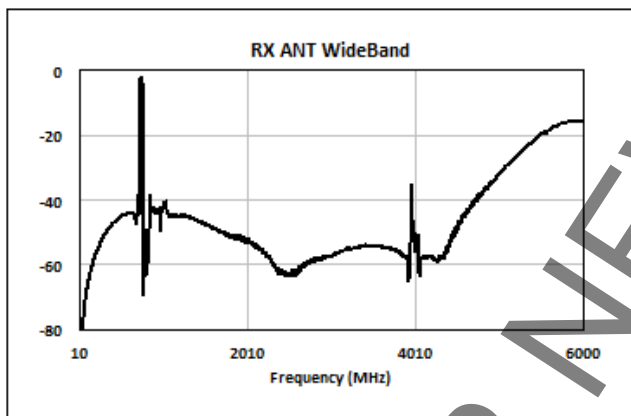
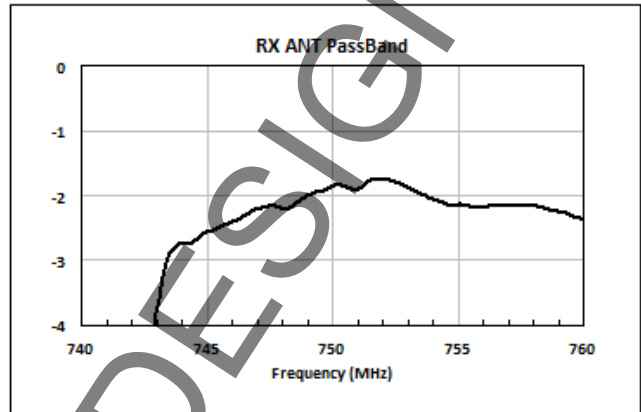
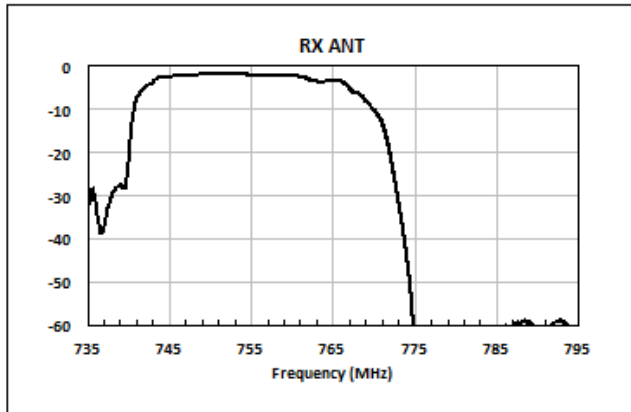

Transmit Performance Plots

Unless Otherwise Noted: Operating Temp = -25 °C

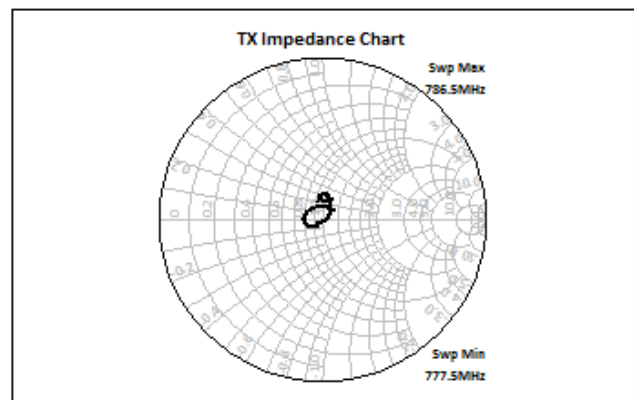
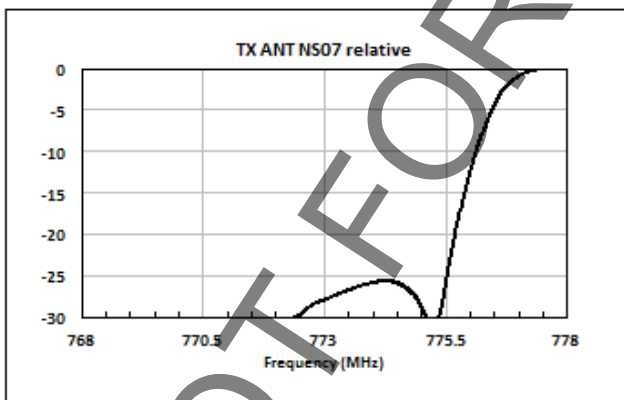
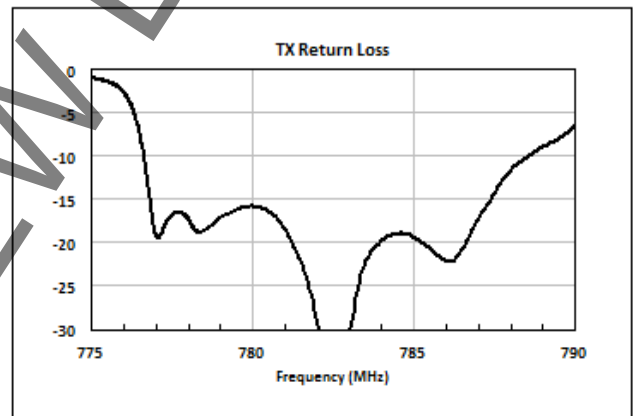
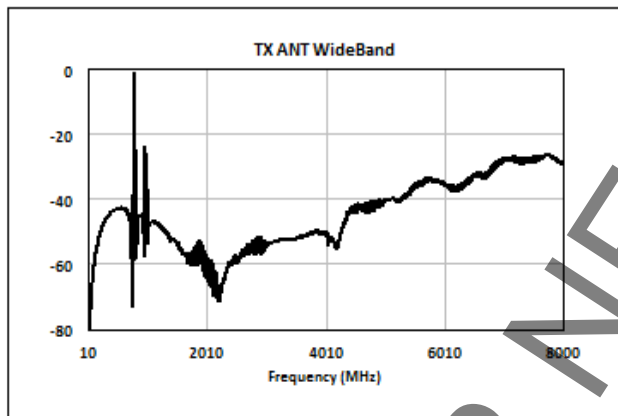
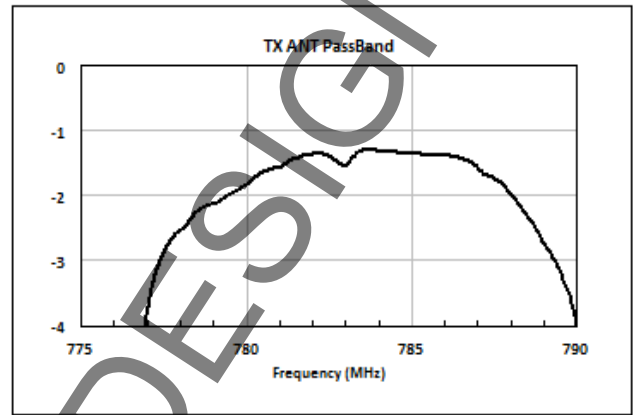
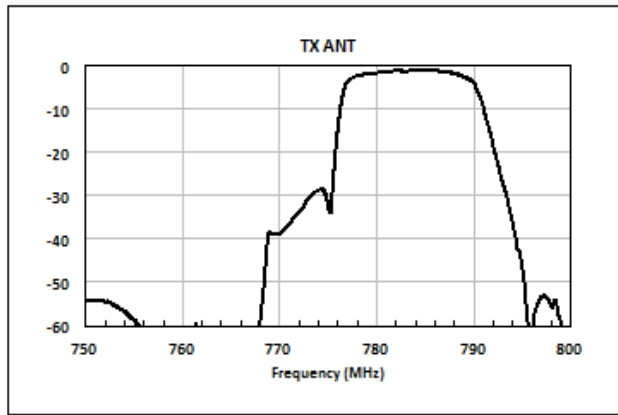

Isolation/Antenna Return Loss

Unless Otherwise Noted: Operating Temp = -25 °C

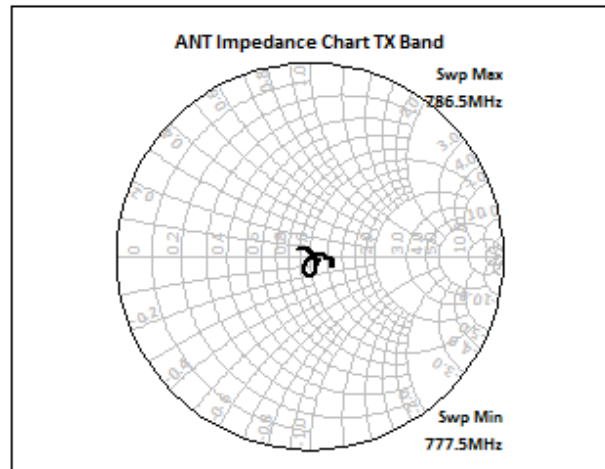
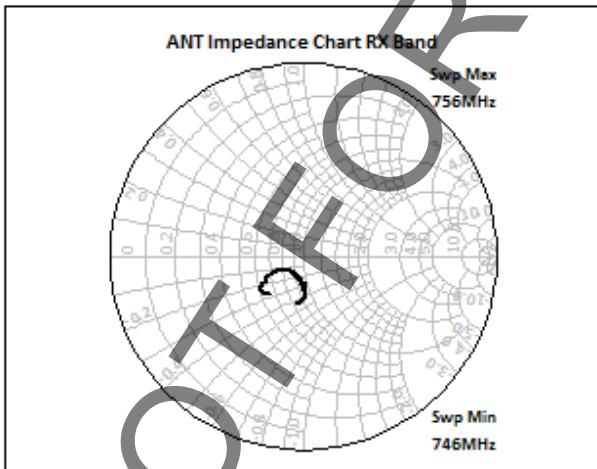
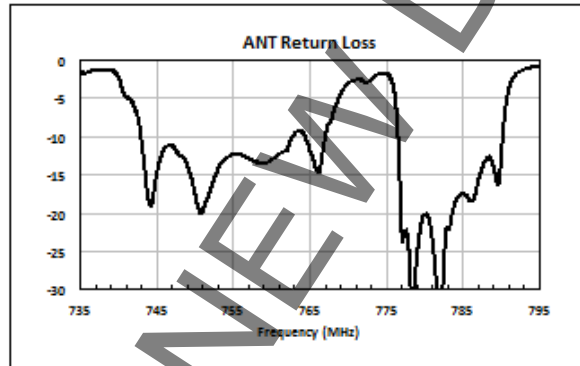
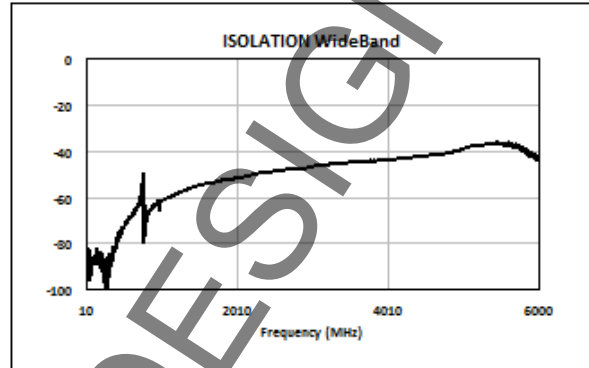
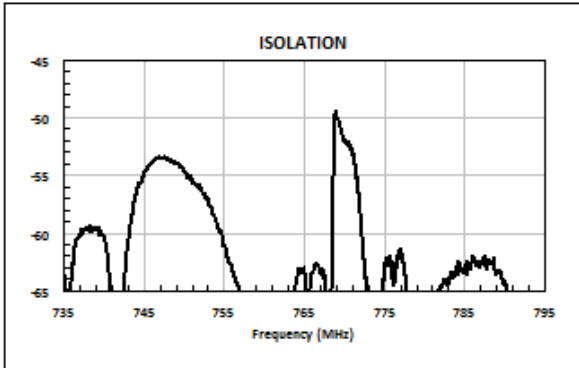

Mechanical Information

Marking

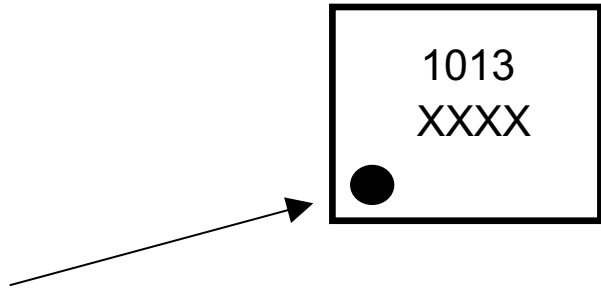

- Pin 1 indicator
- Line 1: Product Name: TQQ1013
- Line 2: Assembly Lot Code #: XXXX= TriQuint assembly number (4 characters only, starting from right side)

Mechanical Information

Package Dimensions

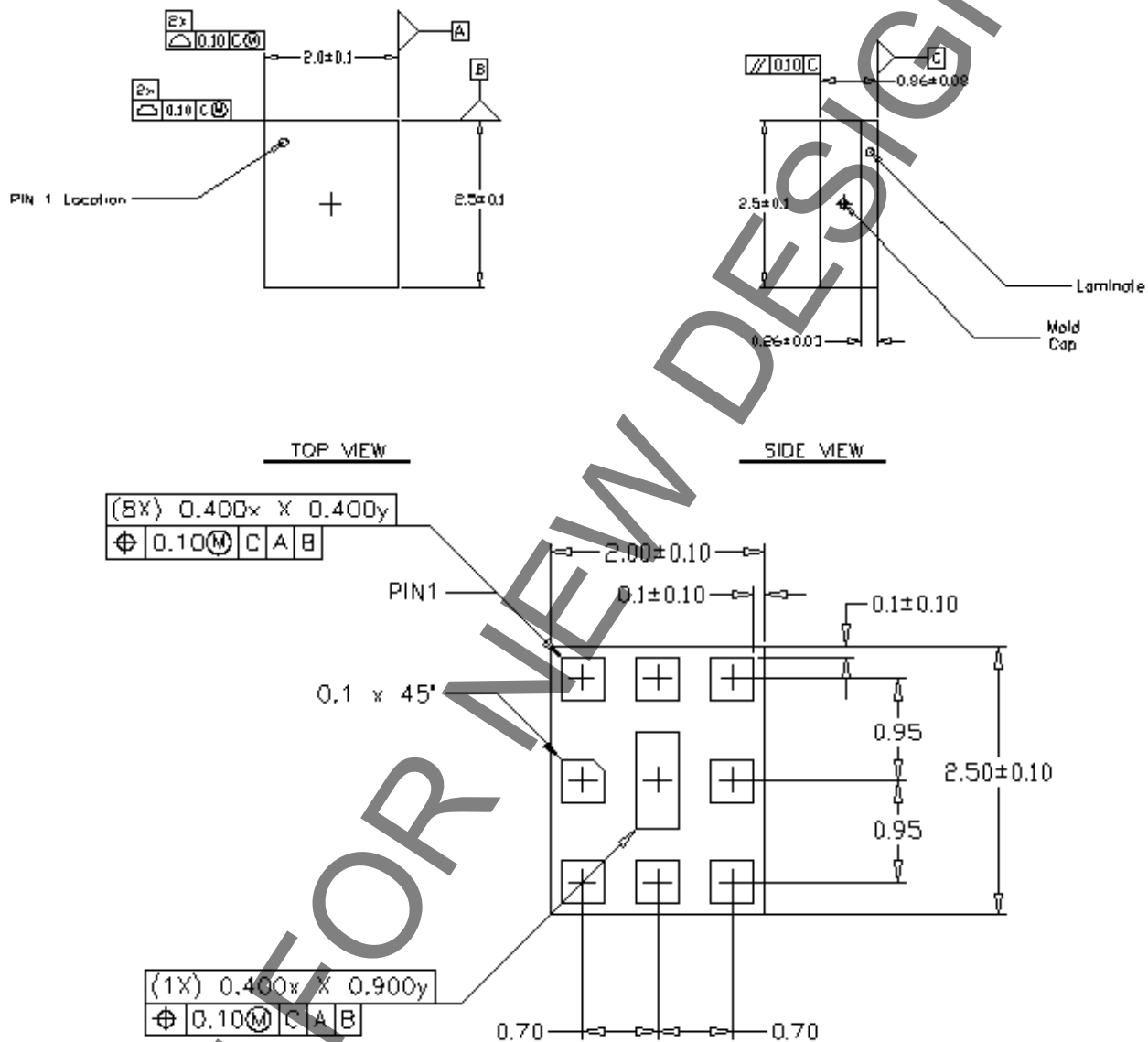

Notes:

1. All dimensions are in millimeters. Angles are in degrees.
2. Dimension and tolerance formats conform to ASME Y14.4M-1994.
3. The terminal #1 identifier and terminal numbering conform to JESD 95-1 SPP-012.

Tape and Reel Information – Carrier and Cover Tape Dimensions

Tape and reel specifications for this part are also available on the TriQuint website.
Standard T/R size = 2500 pieces on a 7" reel.

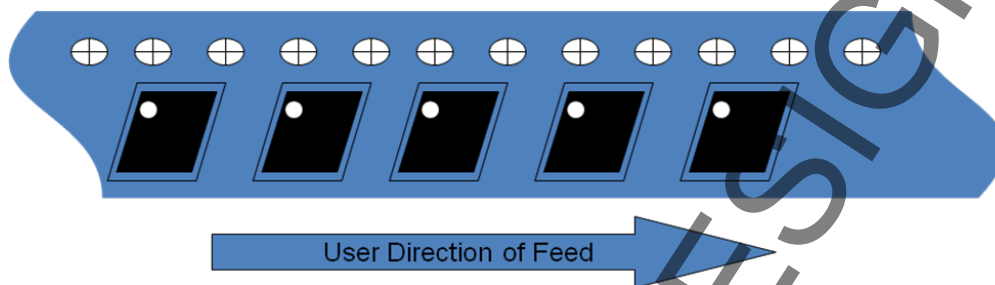

CAVITY (mm)				DISTANCE BETWEEN CENTERLINE (mm)		CARRIER TAPE (mm)	COVER TAPE (mm)
Length (A0)	Width (B0)	Depth (K0)	Pitch (P1)	Length direction (P2)	Width Direction (F)	Width (W)	Width (W)
2.40	2.90	1.10	4.0	2.00	3.50	8.0	5.4

Tape and Reel Information – Tape Length and Label Placement

Tape and reel specifications for this part are also available on the TriQuint website.
Standard T/R size = 2500 pieces on a 7" reel.

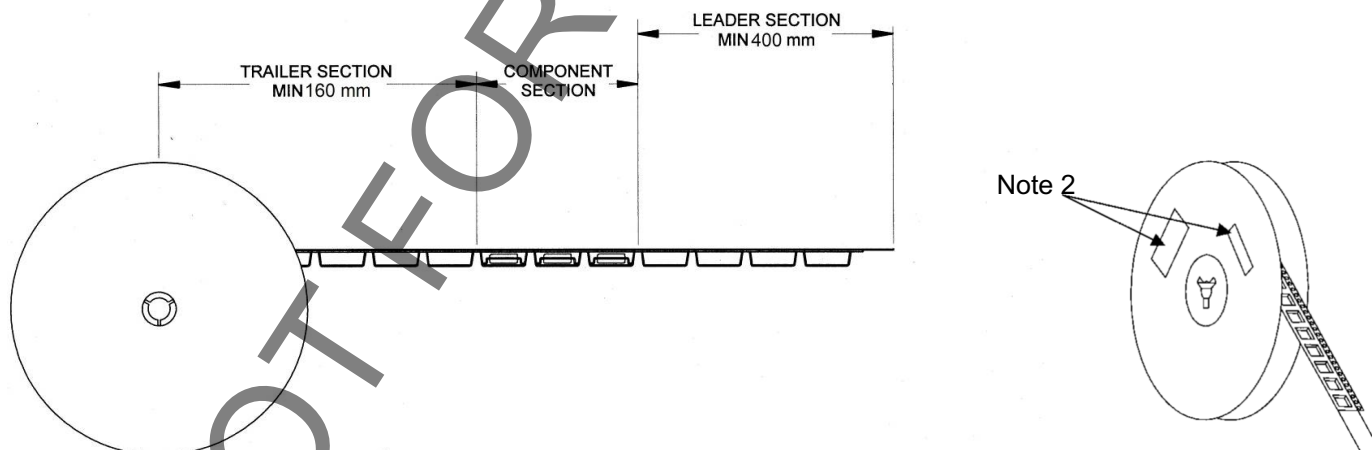

Notes:

1. Empty part cavities at the trailing and leading ends are sealed with cover tape. See EIA 481-1-A.
2. Labels are placed on the flange opposite the sprockets in the carrier tape.

Tape and Reel Information – Reel Dimensions

Packaging reels are used to prevent damage to devices during shipping and storage, loaded carrier tape is typically wound onto a plastic take-up reel. The reel size is 7" diameter. The reels are made from high-impact injection-molded polystyrene (HIPS), which offers mechanical and ESD protection to packaged devices.

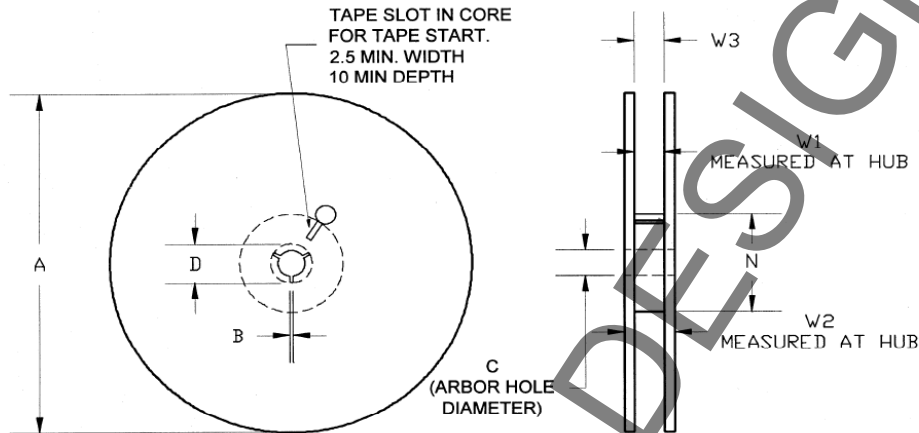

Feature	Measure	Symbol	Size (in)	Size (mm)
Flange	Diameter	A	6.969	177.0
	Thickness	W2	0.559	14.2
	Space Between Flange	W1	0.346	8.8
Hub	Outer Diameter	N	2.283	58.0
	Arbor Hole Diameter	C	0.512	13.0
	Key Slit Width	B	0.079	2.0
	Key Slit Diameter	D	0.787	20.0

NOT FOR NEW DESIGNS

Product Compliance Information

ESD Sensitivity Ratings

Caution! ESD-Sensitive Device

ESD Rating: Class 1A
 Value: ≥ 250 V to < 500 V
 Test: Human Body Model (HBM)
 Standard: JEDEC Standard JS-001-2012

ESD Rating: Class M3
 Value: 250 V
 Test: Machine Model (MM)
 Standard: JEDEC Standard JESD22-A115

MSL Rating

MSL Rating: Level 3
 Test: 260 °C convection reflow
 Standard: JEDEC Standard IPC/JEDEC J-STD-020

Solderability

Compatible with both lead-free (260 °C max. reflow temperature) and tin/lead (245 °C max. reflow temperature) soldering processes.

Package contact plating: Electrolytic Ni/Au

RoHS Compliance

This part is compliant with the 2011/65/EU RoHS directive (Restrictions on the Use of Certain Hazardous Substances in Electrical and Electronic Equipment), as amended by Directive 2015/863/EU

This product also has the following attributes:

- Lead Free
- Halogen Free (Chlorine, Bromine)
- Antimony Free
- TBBP-A (C₁₅H₁₂Br₄O₂) Free
- PFOS Free

Contact Information

For the latest specifications, additional product information, worldwide sales and distribution locations:

Web: www.triquint.com Tel: 1-844-890-8163
 Email: customer.support@qorvo.com

For information about the merger of RFMD and TriQuint as Qorvo:

Web: www.qorvo.com

Important Notice

The information contained herein is believed to be reliable. TriQuint makes no warranties regarding the information contained herein. TriQuint assumes no responsibility or liability whatsoever for any of the information contained herein. TriQuint assumes no responsibility or liability whatsoever for the use of the information contained herein. The information contained herein is provided "AS IS, WHERE IS" and with all faults, and the entire risk associated with such information is entirely with the user. All information contained herein is subject to change without notice. Customers should obtain and verify the latest relevant information before placing orders for TriQuint products. The information contained herein or any use of such information does not grant, explicitly or implicitly, to any party any patent rights, licenses, or any other intellectual property rights, whether with regard to such information itself or anything described by such information.

TriQuint products are not warranted or authorized for use as critical components in medical, life-saving, or life-sustaining applications, or other applications where a failure would reasonably be expected to cause severe personal injury or death.