



Cable drag chain systems



Introduction

Perfect solutions . . .	4
Advantages	6
Overview: internal width/internal height	18
Overview: models/travel distances	20
Overview: features	22
Technical data: open cable drag chains	24
Technical data: closed cable drag chains	32
Information about ESD cable drag chains	36
Choosing a cable drag chain	38
Mounting options	40
Lowered moving end connection	41
Inquiry form	42

Open cable drag chain systems

MP 10.1	45
MP 14	51
MP 15	57
MP 18.1	63
MP 18.2	69
MP 3000	75
MP 32	83
MP 32.2	93
MP 35	103
MP 44	111
MP 41	119
MP 41.2	131
MP 52.1	143
MP 52.2	155
MP 66	169
MP 62.1	177
MP 62.2	189
MP 72	201
MP 82.2	213
MP 102.2	223

Enclosed cable drag chain systems

MP 25 G	235
MP 32.3 G	241
MP 36 G	253
MP 43 G	261
MP 41.3 G	267
MP 52.3 G	281
MP 65 G	295
MP 62.3 G	303
MP 82.3 G	315

Accessory/appendix

VAW Variable guide channel systems	325
ZL Strain relief systems	353
Information about materials	361
Sales agencies	368
Index	370



Perfect solutions start with specific questions



Murrplastik Systemtechnik has been supplying cable drag chain systems for many years. The constant exchange of information with our customers helps us to develop new innovative products, and also to provide a continuous extension of our delivery program. This close relationship with the customer has created cable drag chains that are of great value and use to them.

Our complete range of cable drag chains includes: Cable drag chains, guide channels, cables, strain reliefs, and assembly.

Our chains have demonstrated their quality under the most extreme permanent loads and environmental influences.

In consultation with our customers, our experts select the right solution from our varied and extensive range of systems to suit each customer's individual requirements. As such, we have developed a procedure whereby we can determine customer requirements quickly and precisely and find the right solution for the customer's specific application.



We recommend our assembly handbook as a guide to proper arrangement for cable drag chain systems and integrating them into your facility.

Philosophy of cable drag chains

Murrplastik Systemtechnik offers cable drag chain systems with optimum mechanical features and outstanding application use for our customers.



Atex chains

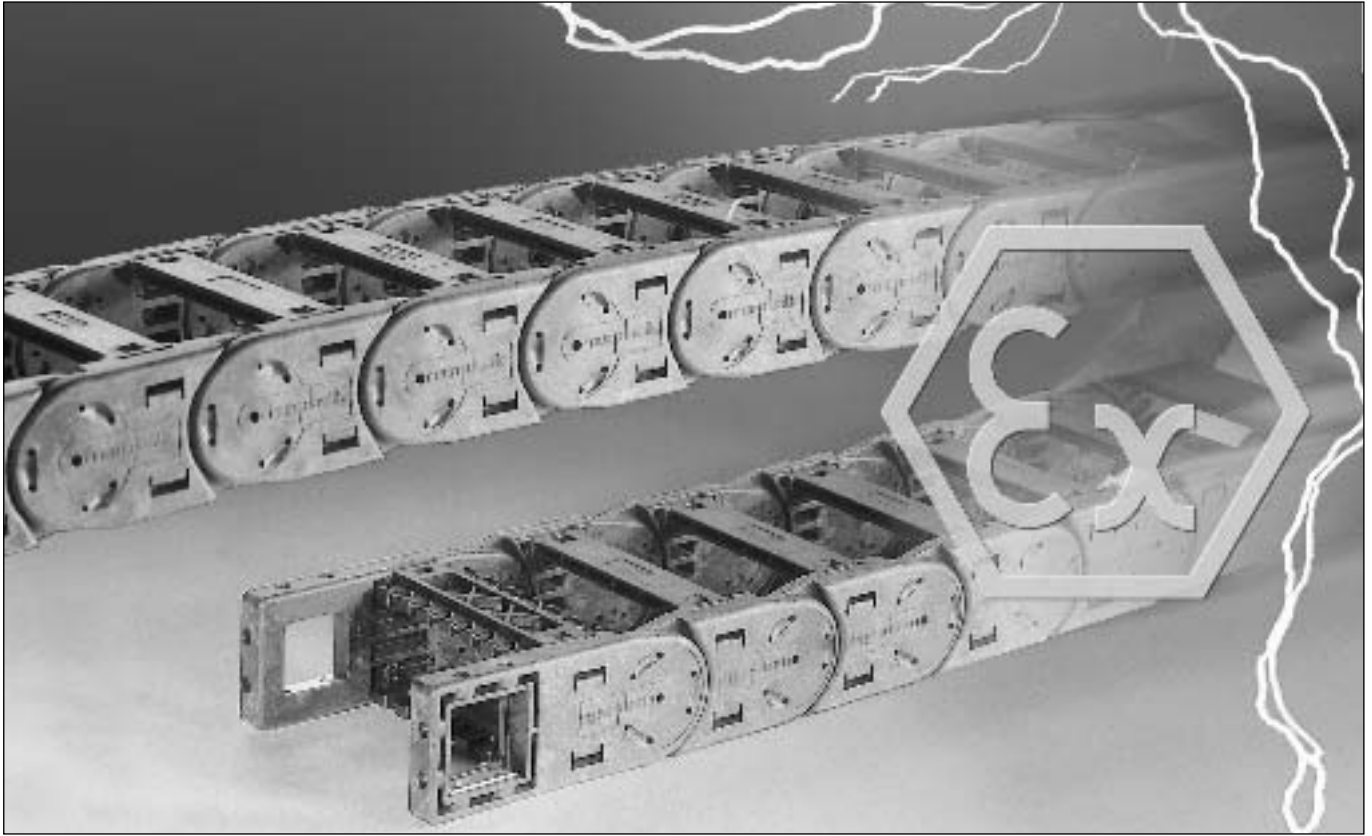

Safety based on ATEX CE EX II 2GD

ESD cable drag chains have a high discharge capability and are used in potentially explosive areas and clean rooms. All mechanical parts have been subject to ATEX standards since July 2003. Our cable drag chains are entitled to carry the following labeling:

CE EX II 2GD

The CE means that Murrplastik has tested its chains as pieces of equipment. This has the following benefits: It is no longer necessary to have the chains approved by an expert. If a chain needs replacing, work can be resumed immediately if the chain in question is the Murrplastik CE chain. Considerable time and expense is saved by not having to go through the approval procedure. CE-certified chains mean you'll never be the weakest link!



- ✓ Full ATEX certification
CE EX II 2GD
- ✓ Simple to exchange,
Certification still stands
- ✓ For Ex zones 1, 2, 21, 22
- ✓ No need for additional acceptance
by experts

Clean room chains

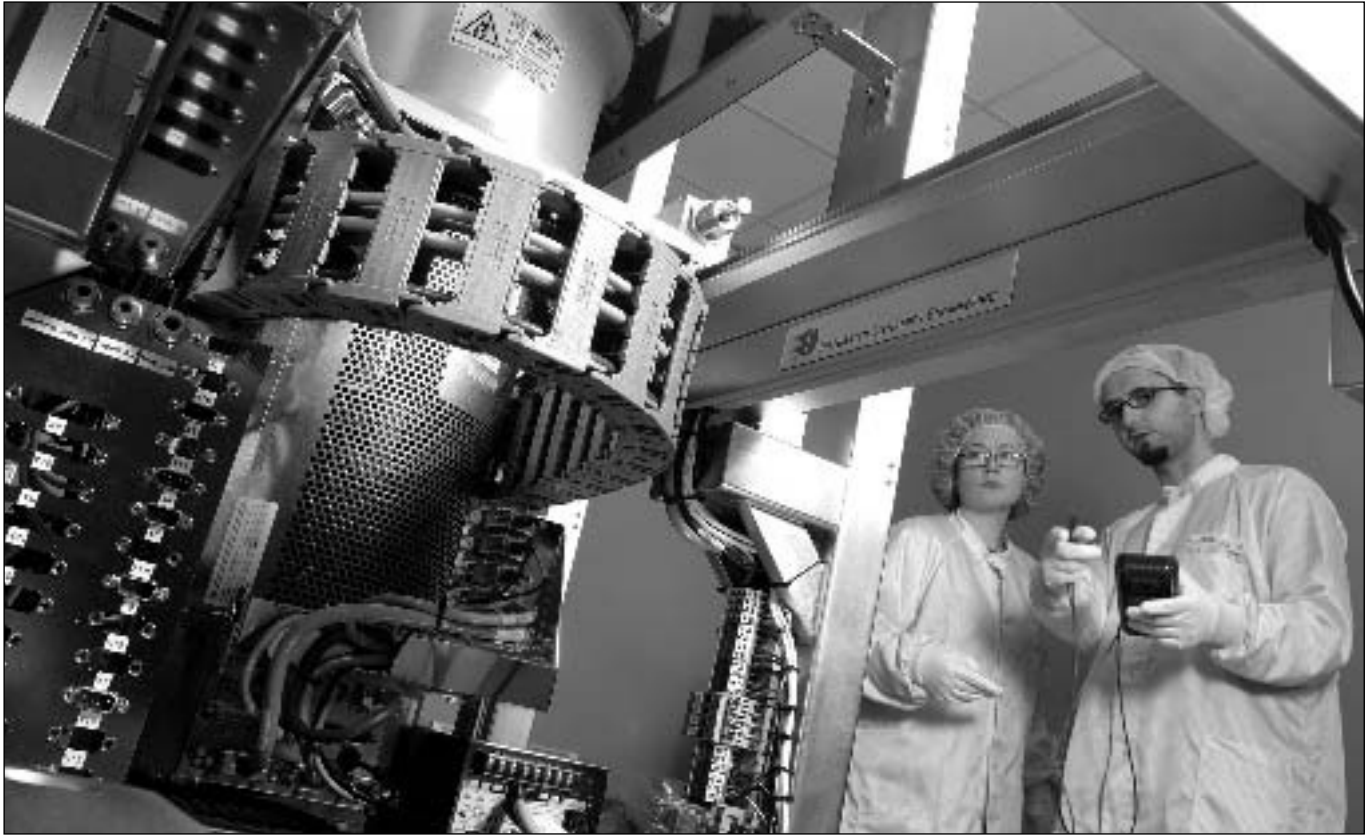

Application in sensitive clean environ- ments

Clean room cable drag chains from Murrplastik Systemtechnik are produced using special materials. The cable drag chains offer premiere clean room properties. With minimal abrasion, and hence particle purity, as well as outstanding discharge of electromagnetic currents, these cable drag chains set new standards.

The discharge capacity fulfills the european ATEX guidelines. Both characteristics, the discharge capacity and abrasion, have been tested and verified by respected institutions.

In spite of the outstanding discharge and abrasion properties, Murrplastik nevertheless refused to compromise in the slightest when it comes to functionality, reliability and ease of assembly.

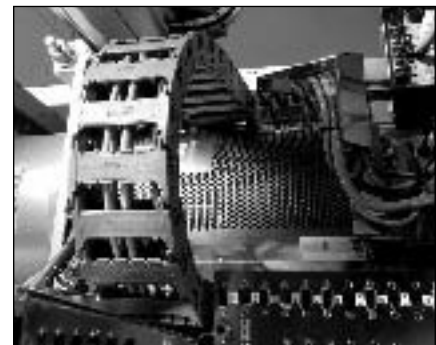

- ✓ Clean room classification by Fraunhofer-Institut (IPA)
- ✓ Fulfills the european ATEX guidelines
- ✓ Uncompromising functionality
- ✓ Unflinching reliability



Click lock

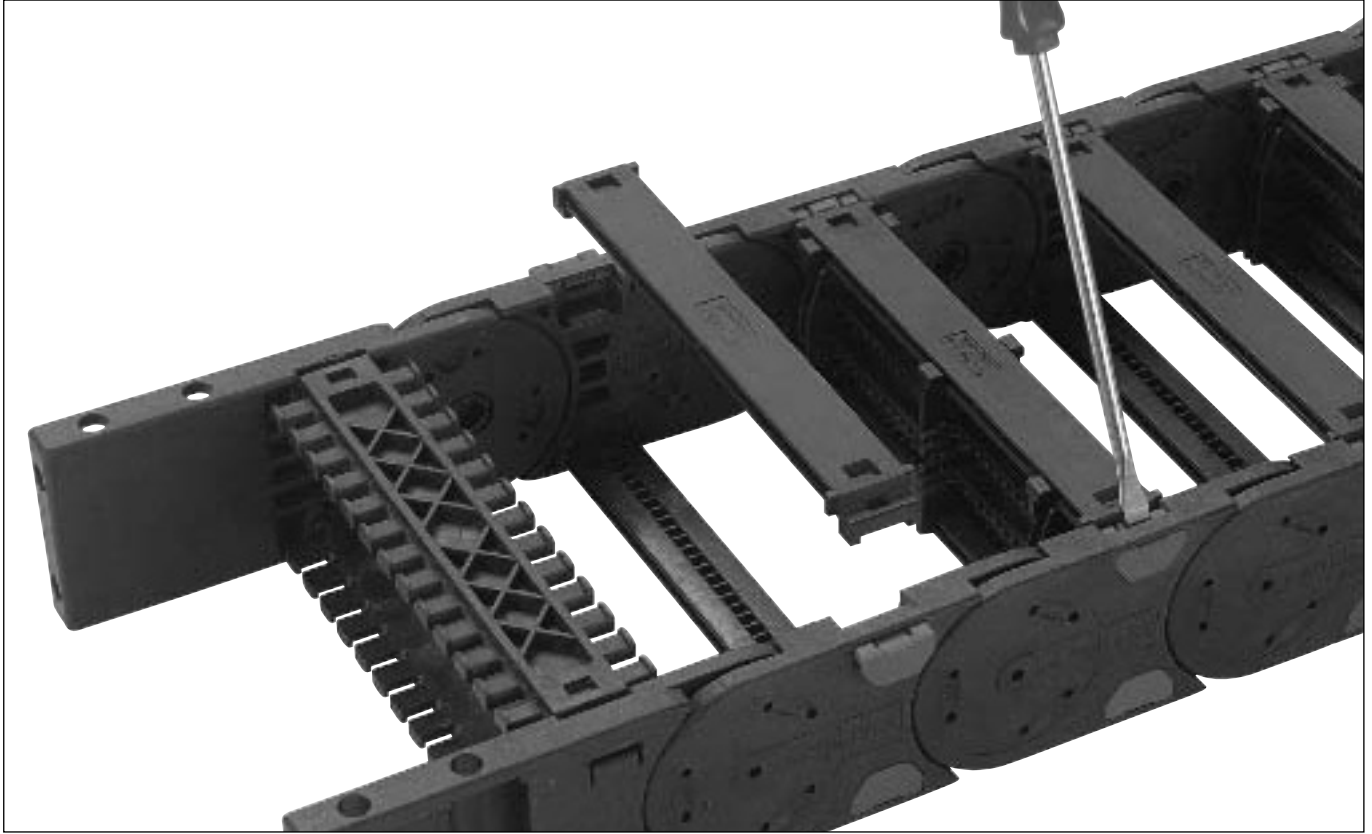

Click and go!

Fast and easy

The frame bridges can be fitted and removed quickly and with very little effort. A slight turn of the screwdriver between the side link and the frame bridge and the click lock is open. Retrofitting a cable in the chain is also a quick and simple task. Assembly is even simpler. Position the frame bridge in the side links and lock the click lock by hand.

With other chains retrofitting is virtually impossible. With the click lock it is child's play.

Fitting and removal are rarely quicker or simpler without compromising stability.



- ✓ **Quick assembly Click and go!**
- ✓ **REFA time and motion study conducted**
- ✓ **Assembly without tools**
- ✓ **Easy assembly**
- ✓ **Incredibly simple to retrofit cables**

Foldable shelf system

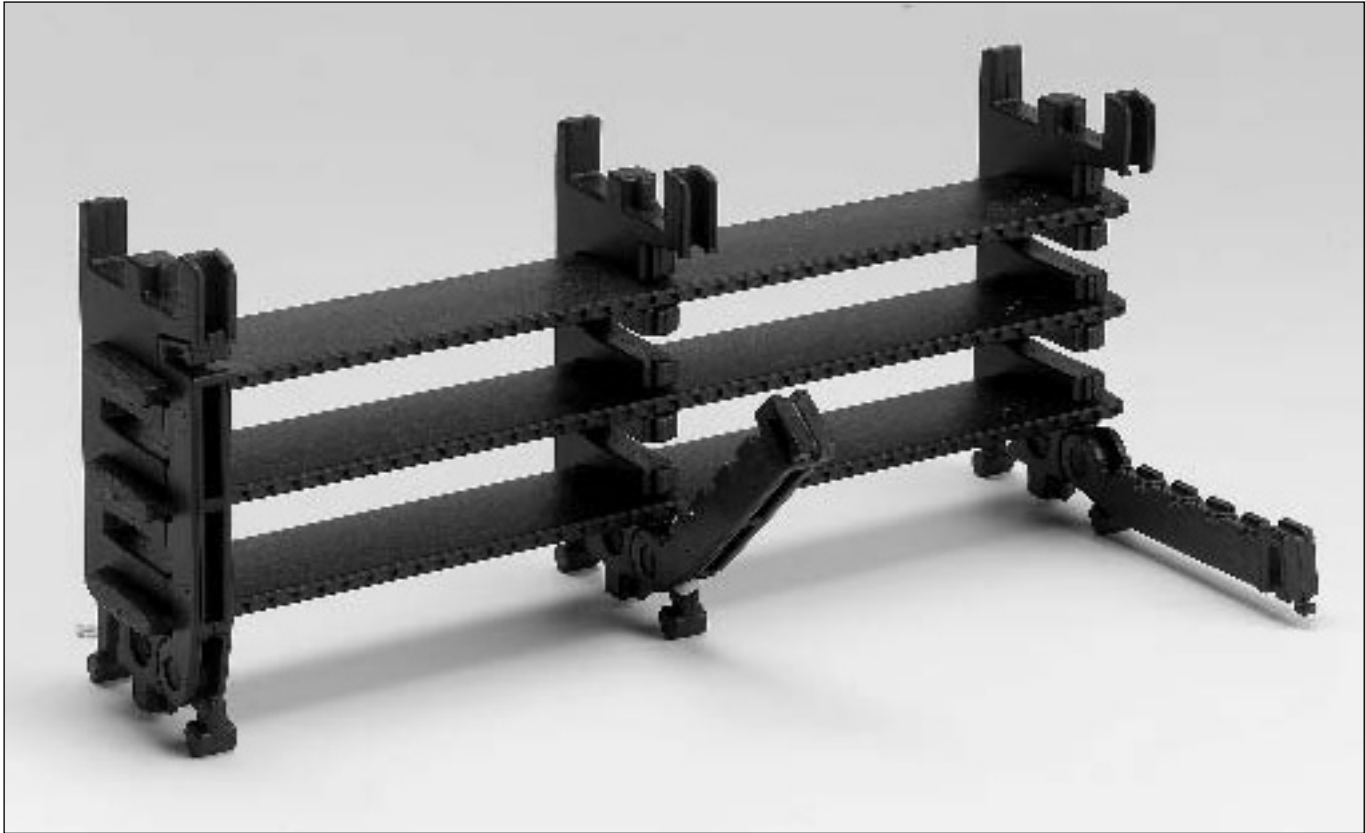

Extremely versatile

Flexibility is the word

The possibilities are endless with the shelf system.

It is ridiculously easy to find the right configuration for each individual requirement. The combination of the click lock and the foldable shelf system even allows modifications to be made when installed.

The shelf separators lock firmly into the frame bridges and, once in place, they cannot slip.

No matter what type of installation – horizontal, backwards, etc. – the cables stay in the position that was originally intended. This means: a long service life and no uneven wear to the chain.

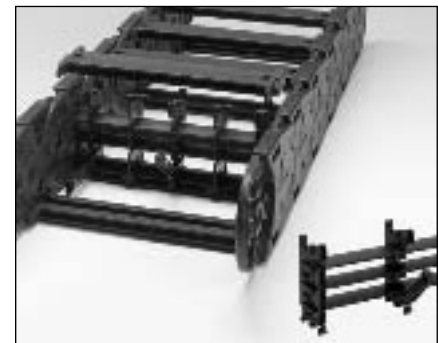

- ✓ **Easy assembly**
- ✓ **REFA time and motion study conducted**
- ✓ **Lockable separator, fixed position**
- ✓ **Quick installation**
- ✓ **Even when installed changes can be made**



Variable frame bridges

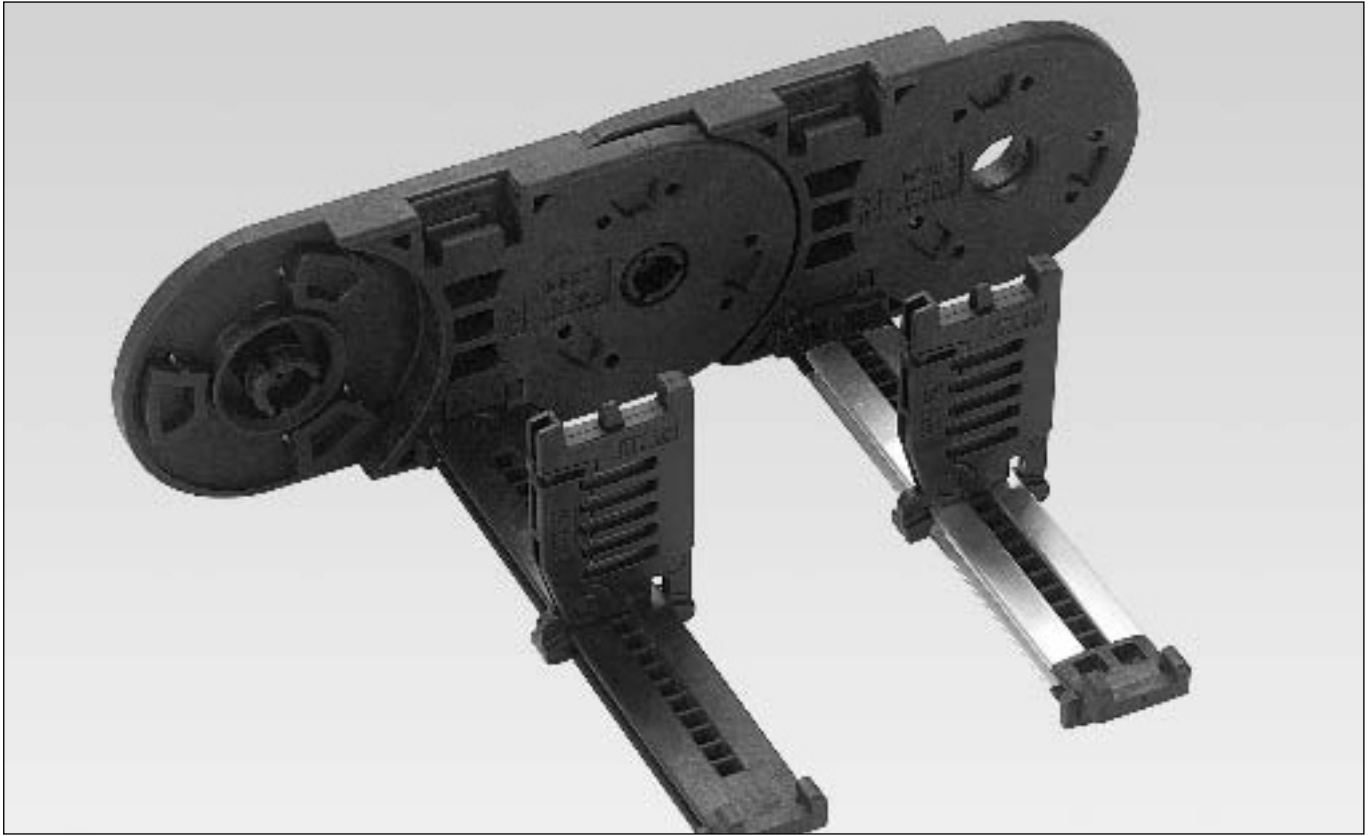

Variable fixed frame bridges

Variable and yet fixed

Crossbars come in two alternative versions: plastic or aluminum.

The plastic version is standard and comes in several widths.

The aluminum version can be supplied in any width. It is especially popular for applications requiring widths of over 21.65 in (550 mm).

The separators, both the plastic and the aluminum ones, lock into the frame bridge and are thus fixed in place. The separators remain in their original position regardless of the type of installation and any movements. The frame bridges and separators form a stable unit.

The Murrplastik frame bridges are variable and yet flexible.

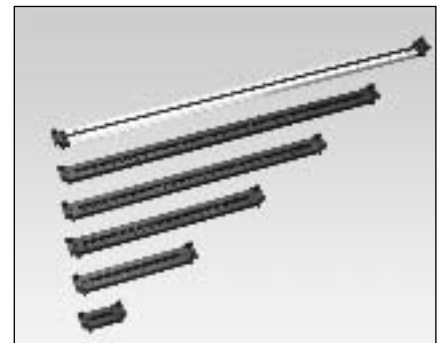

- ✓ **Flexible adjustment due to closely spaced lock tabs**
- ✓ **Fixed with lock tabs**
- ✓ **Variable length**
- ✓ **Extremely stable**

Chain bracket

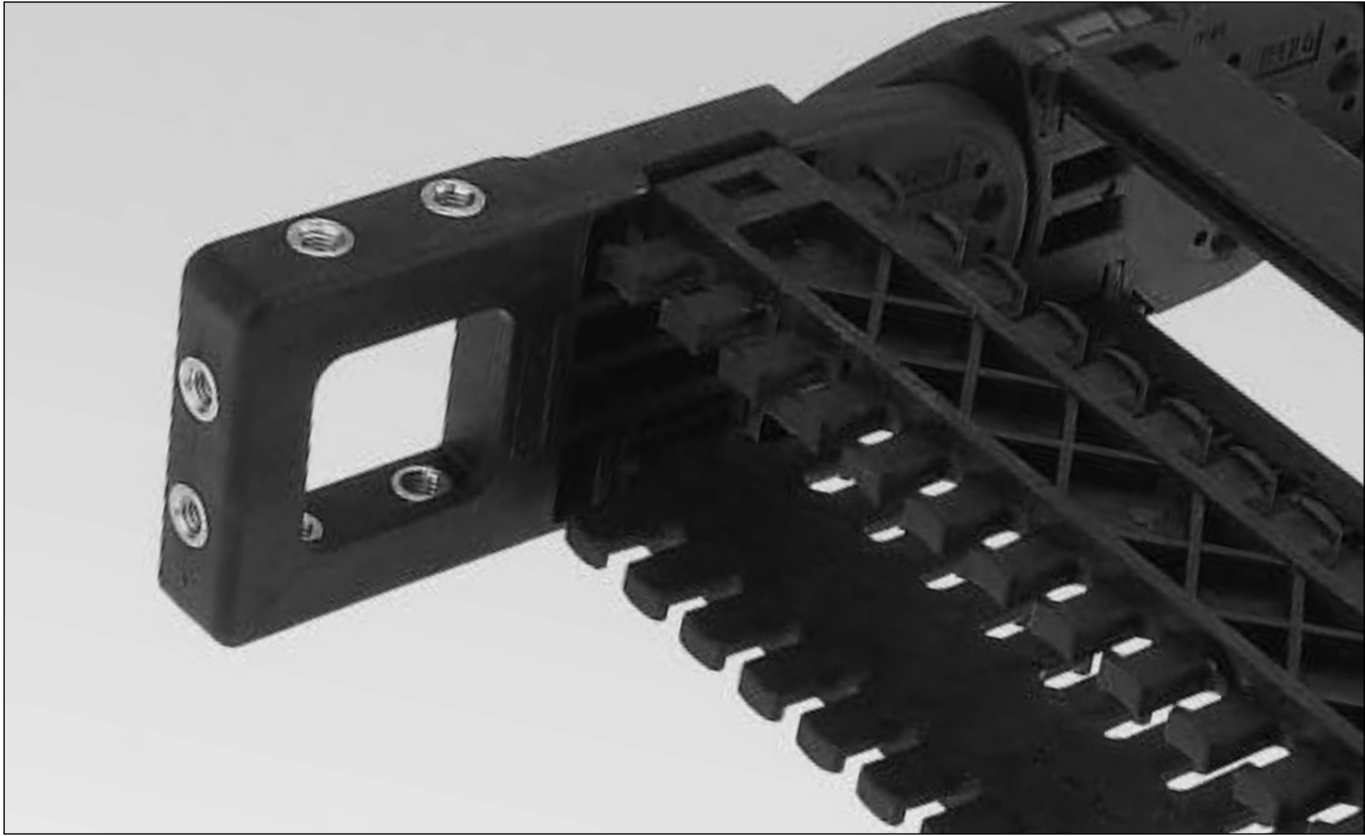

Optimal connections

Fast and easy to assemble

Metal bushings are injected permanently into the plastic in the chain bracket. There are two types: a threaded bushing and a normal one.

Both types of bushing inhibit cold flow properties during screwing, thus effecting an extremely good fit. The threaded bushing is screwed directly without a nut.

Safe and highly compact chain fastening with no fumbling.



- ✓ No cold flow deformation
- ✓ Quick
- ✓ Secure fastening
- ✓ Compact



Integrated strain relief

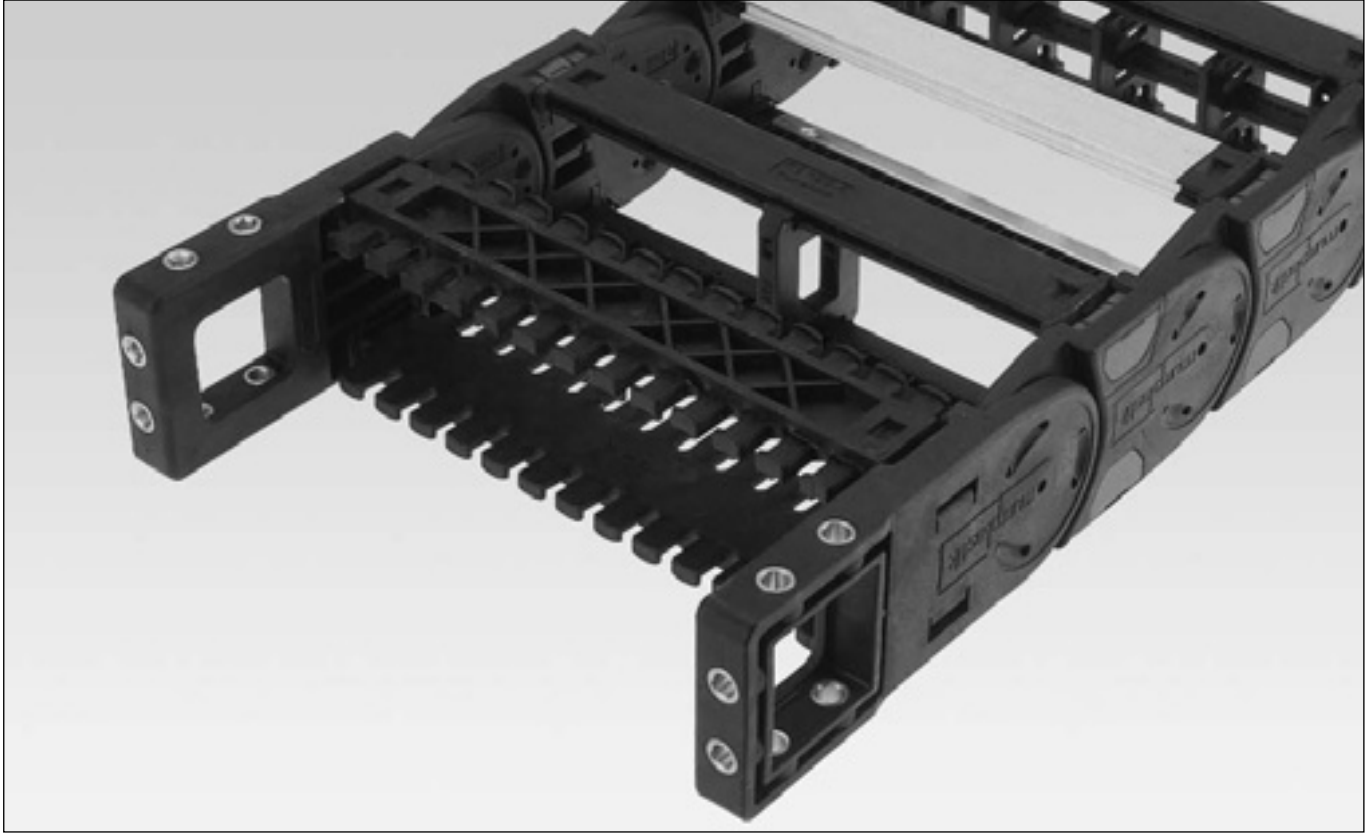

Economic with time and space

Simple and safe strain relief

No cumbersome special design for cable strain relief. Everything is quick and safe with the Murrplastik cable drag chain system.

Special strain relief frame bridges are used on the chain bracket. The strain relief is effected by cable ties. The cable is fixed on the strain relief plate on two sides. It is impossible for the cable plate to slip down because the cable tie is securely enclosed by the plate.

This integrated strain relief system is very quick to assemble and is extremely economical with space.

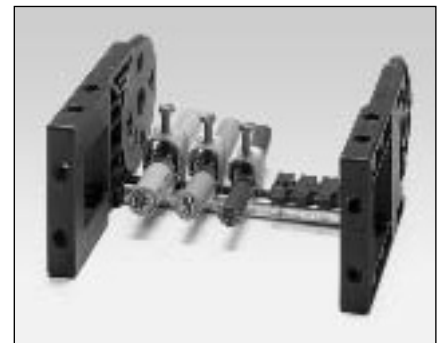

- ✓ Easy to assemble
- ✓ Compact construction
- ✓ Economical
- ✓ Saves space
- ✓ Secure strain relief

Bias



All types of stress

Flexible with a range of options

Low installation height and narrow radii are becoming increasingly important.

These criteria are met by our chain links with reverse radii. This means a smaller radius and no restriction on the position of the chain bracket.

The design remains flexible and compact without compromising service life.

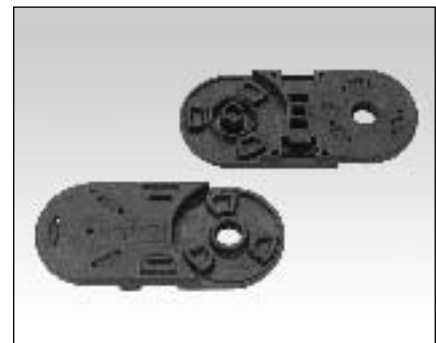

- ✓ Installation space reduced (backwards)
- ✓ Self-supporting position increased (bias)
- ✓ Improved gliding (without bias)
- ✓ Service life prolonged



High acceleration

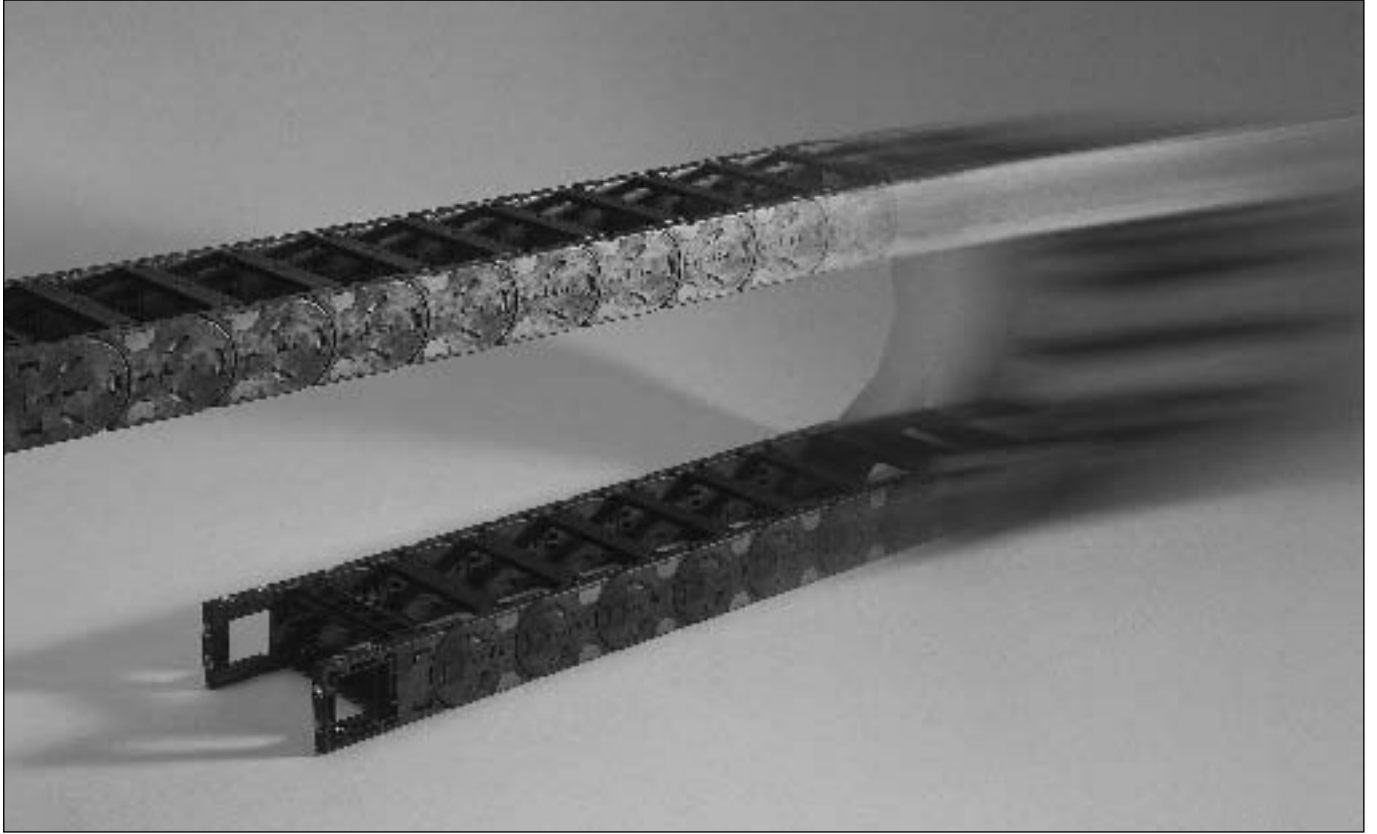

Extreme stresses

High acceleration –
long service life

Are you looking for cable drag chains that can cope with extremely fast acceleration and yet still guarantee long service life?

Then look no further than Murrplastik Systemtechnik.

During the design of our cable drag chains, the focus was on high acceleration rates and long service life. The cable drag chains should not restrict you in the design of your applications.

Even in extreme cases we will be pleased to offer you chains which can withstand extreme stress along with expert advice on applications.



- ✓ **Extreme accelerations**
- ✓ **Long service life**
- ✓ **High continuous load**

VAW guide channels

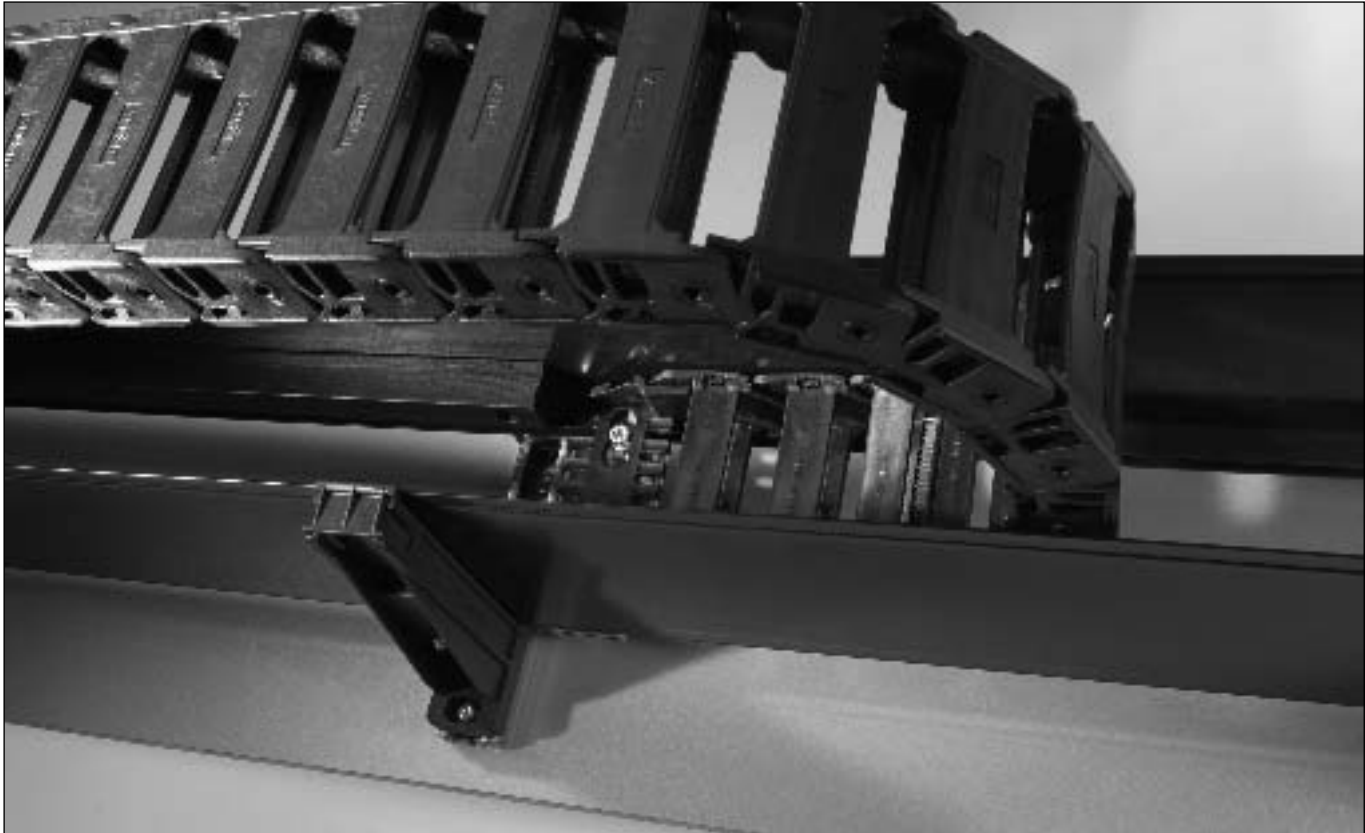

Guide channel system

For maximum speed assembly

The VAW variable guide channel system is harmonized for Murrplastik cable drag chains. The aluminum guide channel system can be adapted quickly to various types and widths of chain.

Assembly is quick and easy:

The aluminum guide channel is secured through clamping pieces on the base. No screwing or welding – simply press special plastic pieces into the groove provided and a perfectly aligned joint is established between two sections.

This carefully designed guide channel system saves up to 70 % working time.



- ✓ **Quick and easy assembly.**
- ✓ **High quality**
- ✓ **Highly economical**
- ✓ **Tailored system**
- ✓ **Long service life**



Fabrication

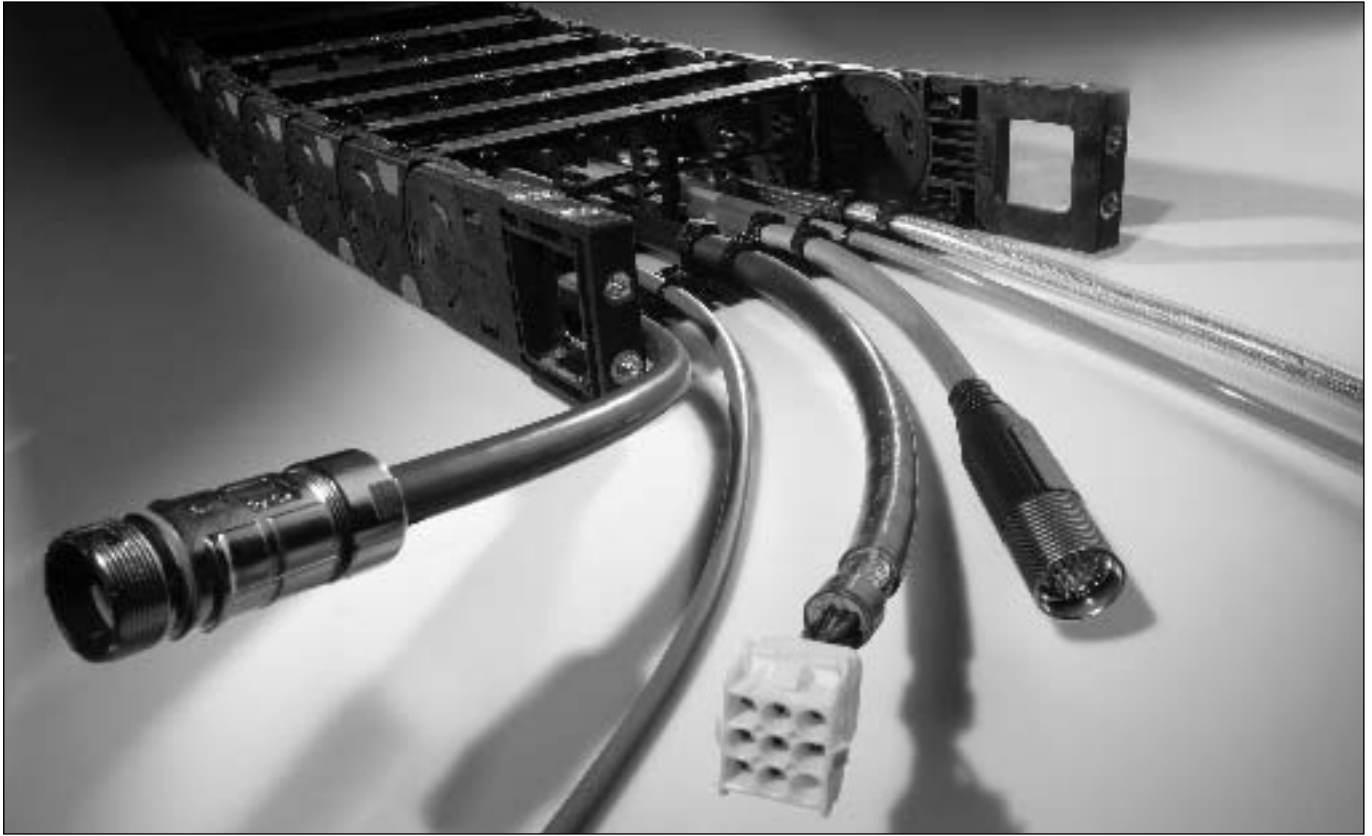

Fabrication

Everything from one source

Reduce your labor costs and save time by taking advantage of the experience in chain systems we've gained over many years.

At the customer's request we assemble complete cable drag chains with cables. We handle the layout, assembly and ordering of individual components. The customer is supplied with a ready-made assembly which only needs to be fitted.

Thanks to the experience in cable drag chains and cables we've acquired over many years, we can combine both elements in one system. This guarantees a long service life.



- ✓ **System guarantee**
- ✓ **Easy handling**
- ✓ **Saves time and hassle when ordering**
- ✓ **Reduced warehousing costs**

Visual differentiation



Optical differentiation

Extreme areas of application require different materials.

The Murrplastik color coding system enables you to recognise and classify different materials and hence areas of application safely and easily.

Clear assignments, safe use – as with all Murrplastik products.

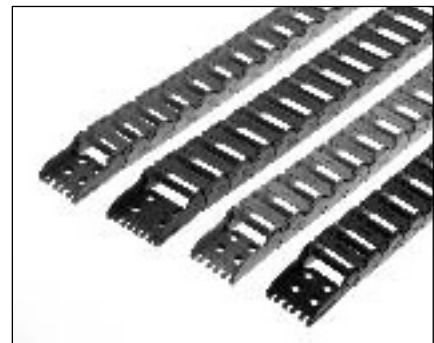



- ✓ Murrplastik color coding system
- ✓ Black cable drag chains:
Polyamide (PA): standard
- ✓ Light gray cable drag chains:
Polyamide (PA): ESD model
- ✓ Oxide red cable drag chains:
Polyamide (PA), UL 94/V0
- ✓ Blue cable drag chains:
Polypropylene (PP)



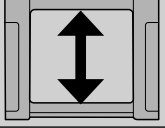
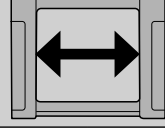
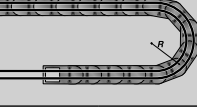
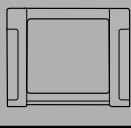
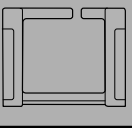
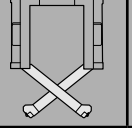
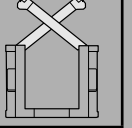

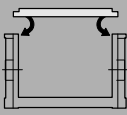
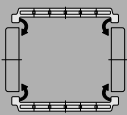
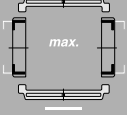
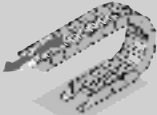



Overview models/travel distances

Chain type	Dimensions					Opening variants			
									
	Internal height	Inside width		Bending radius		None	Slit	Inside bend foldable	Outside bend foldable
	in inch	in inch		in inch					
		From	To	From	To				
10.1	0.39	0.24	1.61	0.71	2.28		■		
14	0.55	0.63	1.57	0.98	2.95				■
15	0.59	0.63	1.57	0.98	2.95	■			
18.1	0.71	0.59	2.76	1.10	3.07				■
18.2									■
25 G	0.98	1.02	4.92	2.36	9.84			■	
3000	1.02	1.02	4.92	1.97	11.81			■	
32	1.26	1.77	21.50	3.15	9.84				
32.2				4.72					
32.3 G									
35	1.34	2.44	5.91	2.76	11.81				
36 G	1.42	2.44	4.92	3.15	7.87			■	
43 G	1.50	2.44	7.17	4.92	9.84				
44	1.57	1.77	7.17	3.54	9.84				
41	1.65	1.77	21.50	2.95	11.81				
41.2				5.91					
41.3 G									
52.1	2.05	1.77	21.50	3.94	13,78				
52.2				5.91					
52.3 G									
65 G	2.36	3.31	5.67	7.87	13,78				
66		1.77	7.17	5.91					
62.1	2.44	4.65	20.39	5.91	19.69				
62.1				7.87					
62.3 G									
72	2.83	4.65	20.39	5.91	19.69				
82.2	3.23	4.65	20.39	5.91	19.69				
82.3 G				7.87					
102.2	4.02	4.65	20.39	9.84	19.69				

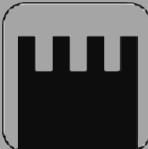
Opening variants			Parameters						
			 						
Inside bend engages	Inside and outside bend engage	Inside and outside bend click lock	Travel distance		Speed		Acceleration		
			Unsupported	Gliding	Unsupported	Gliding	Unsupported	Gliding	
			ft		ft/s		ft/s ²		
			3.28	32.81	13.12	13.12	13.12	13.12	
			6.56	39.37	13.12	13.12	13.12	13.12	
			6.56	39.37	13.12	13.12	13.12	13.12	
			9.84	65.62	16.40	13.12	16.40	16.40	
			9.84	-	16.40	-	16.40	-	
			9.84	131.23	19.69	9.84	49.21	32.81	
			13.12	196.85	19.69	9.84	49.21	32.81	
	■		14.76	328.08	65.62	16.40	98.43	82.02	
		■	14.76	328.08	65.62	16.40	98.43	82.02	
		■	14.76	328.08	65.62	16.40	98.43	82.02	
■			14.76	262.47	32.81	9.84	65.62	49.21	
			13.12	262.47	32.81	9.84	65.62	49.21	
	■		16.40	164.04	49.21	16.40	65.62	49.21	
	■		16.40	164.04	49.21	16.40	65.62	49.21	
	■		22.97	393.70	65.62	16.40	98.43	82.02	
		■	22.97	393.70	65.62	16.40	98.43	82.02	
		■	22.97	393.70	65.62	16.40	98.43	82.02	
	■		29.53	492.13	65.62	16.40	98.43	49.21	
		■	29.53	492.13	65.62	16.40	98.43	82.02	
		■	29.53	492.13	65.62	16.40	98.43	82.02	
	■		26.25	196.85	49.21	16.40	82.02	49.21	
	■		26.25	196.85	49.21	16.40	82.02	49.21	
	■		32.81	590.55	65.62	16.40	131.23	82.02	
		■	32.81	590.55	65.62	16.40	131.23	82.02	
		■	32.81	590.55	65.62	16.40	131.23	82.02	
	■		32.81	656.17	65.62	16.40	131.23	82.02	
		■	36.09	820.21	65.62	16.40	131.23	82.02	
		■	36.09	820.21	65.62	16.40	131.23	82.02	
		■	39.37	984.25	65.62	16.40	131.23	82.02	

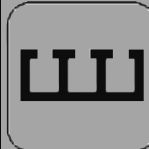

Overview features

Internal height in inch (mm)	Chain type	Chain bracket										Separator	
													
		Standard U-chain segments	Flexible with bush or threads		Angle Sideband chains		Angle U-chain segments		Bracket U-part		Flange		
		Plastic	With stop	without stop	Steel galvanised	Stainless steel	Steel galvanised	Stainless steel	Steel galvanised	Stainless steel	Steel galvanised	Stainless steel	Fixed division
0.39 (10)	10.1	■										■	
0.55 (14)	14	■											
0.59 (15)	15	■											
0.71 (18)	18.1	■											
	18.2	■											
0.98 (25)	25 G							■	■				
1.02 (26)	3000	■					■	■					
1.26 (32)	32		■	■									
	32.2		■	■									
	32.3 G		■	■									
1.34 (34)	35					■	■	■	■				
1.42 (36)	36 G							■	■	■	■		
1.50 (38)	43 G				■	■							
1.57 (40)	44				■	■				1.77 in			
1.65 (42)	41		■		■	■							
	41.2		■		■	■							
	41.3 G		■		■	■							
2.05 (52)	52.1		■		■								
	52.2		■		■								
	52.3 G		■		■								
2.36 (60)	65 G				■	■		■		■	■		
	66				■	■				1.77 in			
2.44 (62)	62.1		■		■								
	62.1		■		■								
	62.3 G		■		■								
2.83 (72)	72		■		■								
3.23 (82)	82.2		■										
	82.3 G		■										
4.02 (102)	102.2		■		■								



Technical data: open cable drag chains

MP 10.1

Page 45

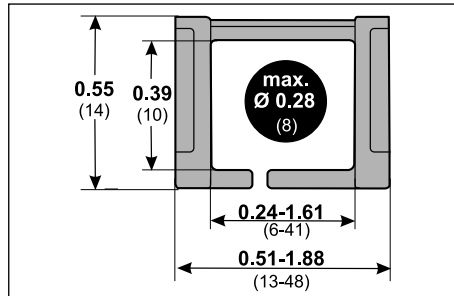

- Interior height: 0.39 in (10 mm)
- Interior widths: 0.24–1.61 in (6–41 mm)
- Radii: 0.71–2.28 in (18–58 mm)
- Pitch: 0.59 in (15 mm)
- Links per foot (meter): 21 (67) pc
- Loading side: outside flexure curve slitted

MP 14

Page 51

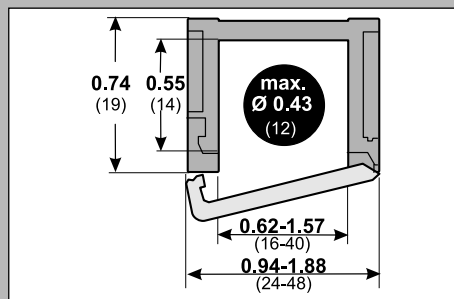

- Interior height: 0.55 in (14 mm)
- Interior widths: 0.63–1.57 in (16–40 mm)
- Radii: 0.98–2.95 in (25–75 mm)
- Pitch: 1.02 in (26 mm)
- Links per foot (meter): 12 (38) pc
- Loading side: outside flexure curve

MP 15

Page 57

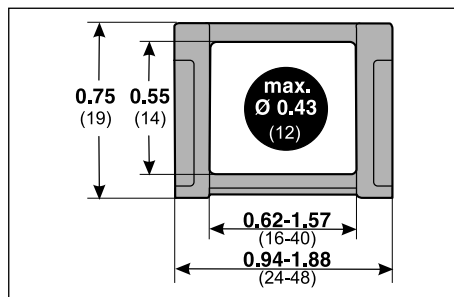

- Interior height: 0.55 in (14 mm)
- Interior widths: 0.63–1.57 in (16–40 mm)
- Radii: 0.98–2.95 in (25–75 mm)
- Pitch: 1.02 in (26 mm)
- Links per foot (meter): 12 (38) pc
- Loading side: Non-opening

MP 18.1

Page 63

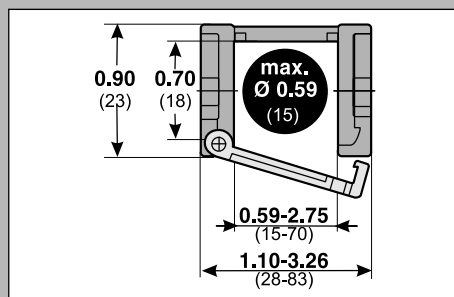

- Interior height: 0.71 in (18 mm)
- Interior widths: 0.59–2.76 in (15–70 mm)
- Radii: 1.10–3.07 in (28–78 mm)
- Pitch: 1.30 in (33 mm)
- Links per foot (meter): 10 (30) pc
- Loading side: outside flexure curve

MP 18.2

Page 69

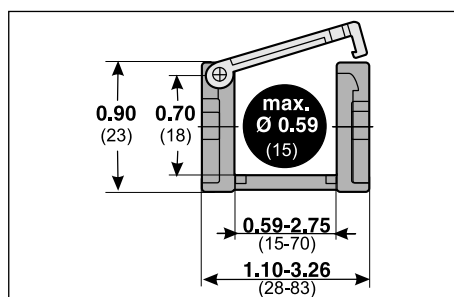

- Interior height: 0.71 in (18 mm)
- Interior widths: 0.59–2.76 in (15–70 mm)
- Radii: 1.10–3.07 in (28–78 mm)
- Pitch: 1.30 in (33 mm)
- Links per foot (meter): 10 (30) pc
- Loading side: inside flexure curve

- Travel distance, gliding: 32.81 ft
- Travel distance, self-supporting: see diagram
- Travel distance, vertical, hanging: 6.56 ft
- Travel distance, vertical, upright: 3.28 ft
- Rotated 90°, unsupported: not recommended
- Speed, gliding 6.56 ft/s
- Speed, unsupported 13.12 ft/s
- Acceleration, gliding 6.56 ft/s²
- Acceleration, unsupported 6.56 ft/s²

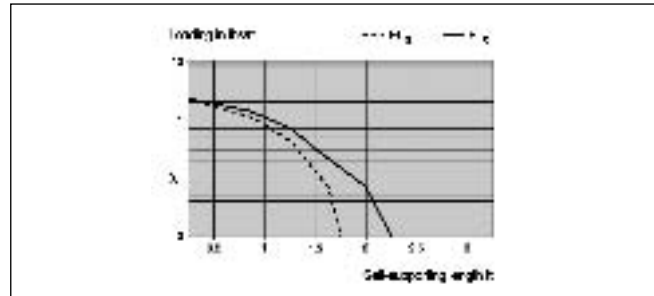

- Travel distance, gliding: 39.37 ft
- Travel distance, self-supporting: see diagram
- Travel distance, vertical, hanging: 9.84 ft
- Travel distance, vertical, upright: 6.56 ft
- Rotated 90°, unsupported: not recommended
- Speed, gliding 6.56 ft/s
- Speed, unsupported 13.12 ft/s
- Acceleration, gliding 6.56 ft/s²
- Acceleration, unsupported 6.56 ft/s²

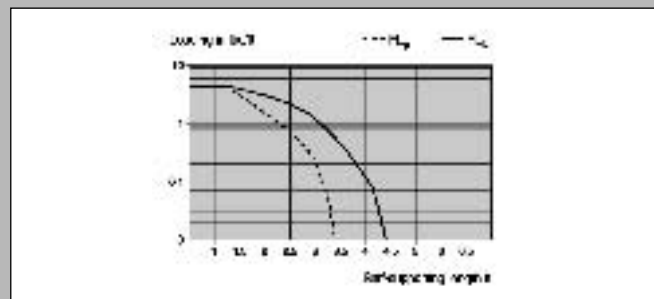

- Travel distance, gliding: 39.37 ft
- Travel distance, self-supporting: see diagram
- Travel distance, vertical, hanging: 9.84 ft
- Travel distance, vertical, upright: 6.56 ft
- Rotated 90°, unsupported: not recommended
- Speed, gliding 6.56 ft/s
- Speed, unsupported 13.12 ft/s
- Acceleration, gliding 6.56 ft/s²
- Acceleration, unsupported 6.56 ft/s²

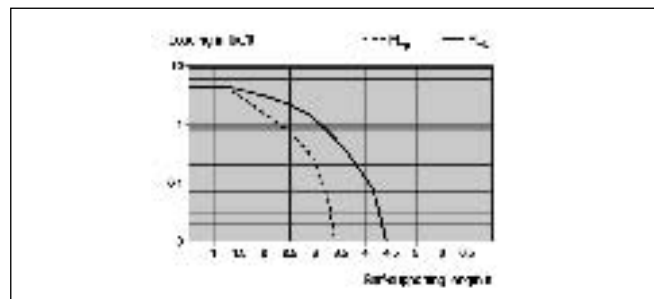

- Travel distance, gliding: 65.62 ft
- Travel distance, self-supporting: see diagram
- Travel distance, vertical, hanging: 26.25 ft
- Travel distance, vertical, upright: 9.84 ft
- Rotated 90°, unsupported: 1.64 ft
- Speed, gliding 6.56 ft/s
- Speed, unsupported 16.40 ft/s
- Acceleration, gliding 16.40 ft/s²
- Acceleration, unsupported 16.40 ft/s²

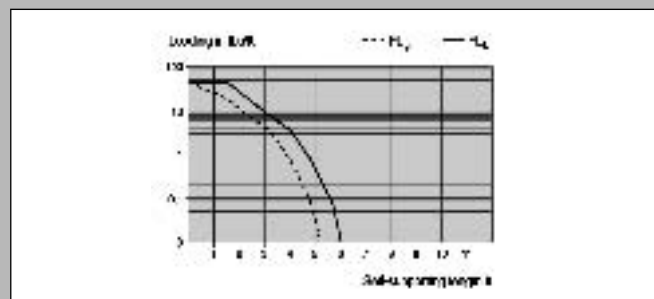

- Travel distance, gliding: not recommended
- Travel distance, self-supporting: see diagram
- Travel distance, vertical, hanging: 26.25 ft
- Travel distance, vertical, upright: 9.84 ft
- Rotated 90°, unsupported: 1.64 ft
- Speed, unsupported 16.40 ft/s
- Acceleration, unsupported 16.40 ft/s²

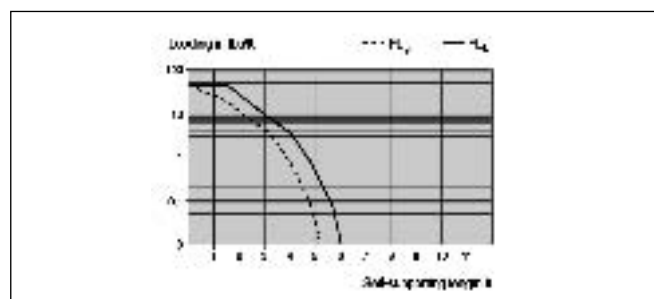



Technical data: open cable drag chains

MP 3000

Page 75

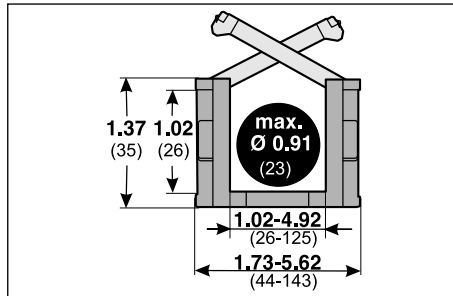

- Interior height: 1.02 in (26 mm)
- Interior widths: 1.02–4.92 in (26–125 mm)
- Radii: 1.97–11.81 in (50–300 mm)
- Pitch: 1.77 in (45 mm)
- Links per foot (meter): 7 (22) pc
- Loading side: inside flexure curve
- Existing shelving system

MP 32

Page 83

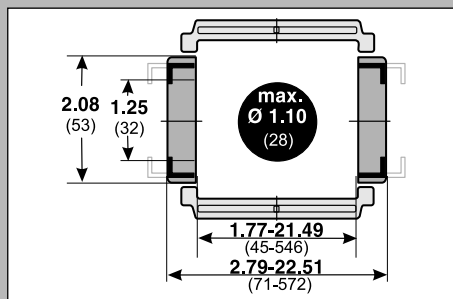

- Interior height: 1.26 in (32 mm)
- Interior widths: 1.77–21.50 in (45–546 mm)
- Radii: 3.15–9.84 in (80–250 mm)
- Pitch: 2.54 in (64,5 mm)
- Links per foot (meter): 5 (16) pc
- Loading side: inside and outside flexure curve
- Existing shelving system

MP 32.2

Page 93

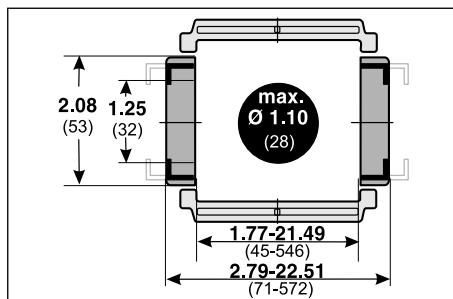

- Interior height: 1.26 in (32 mm)
- Interior widths: 1.77–21.50 in (45–546 mm)
- Radii: 3.15–9.84 in (80–250 mm)
- Pitch: 2.54 in (64,5 mm)
- Links per foot (meter): 5 (16) pc
- Loading side: inside and outside flexure curve
- Existing shelving system

MP 35

Page 103

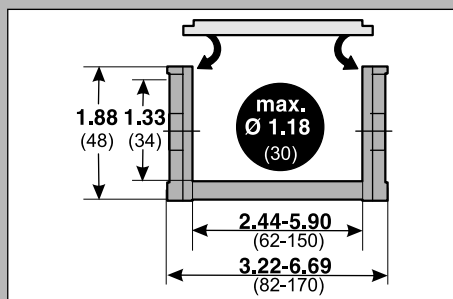

- Interior height: 1.34 in (34 mm)
- Interior widths: 2.44–5.91 in (62–150 mm)
- Radii: 2.76–11.81 in (70–300 mm)
- Pitch: 2.28 in (58 mm)
- Links per foot (meter): 6 (17) pc
- Loading side: inside flexure curve
- Existing shelving system

MP 44

Page 111

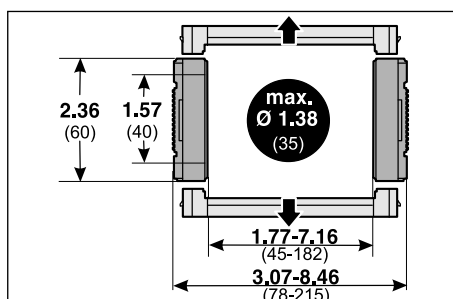

- Interior height: 1.57 in (40 mm)
- Interior widths: 1.77–7.17 in (45–182 mm)
- Radii: 3.54–9.84 in (90–250 mm)
- Pitch: 2.97 in (75,5 mm)
- Links per foot (meter): 4 (13) pc
- Loading side: inside and outside flexure curve
- Existing shelving system

- Travel distance, gliding: 196.85 ft
- Travel distance, self-supporting: see diagram
- Travel distance, vertical, hanging: 131.23 ft
- Travel distance, vertical, upright: 9.84 ft
- Rotated 90°, unsupported: 2.30 ft
- Speed, gliding 9.84 ft/s
- Speed, unsupported 19.69 ft/s
- Acceleration, gliding 32.81 ft/s²
- Acceleration, unsupported 49.21 ft/s²

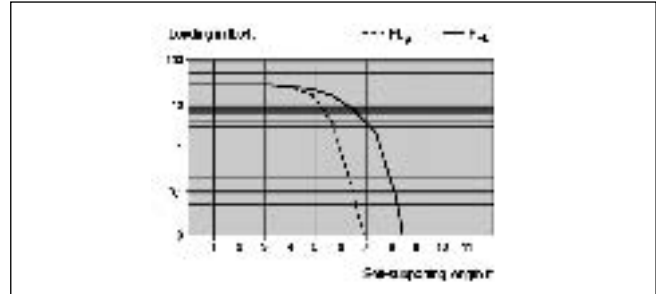

- Travel distance, gliding: 328.08 ft
- Travel distance, self-supporting: see diagram
- Travel distance, vertical, hanging: 196.85 ft
- Travel distance, vertical, upright: 16.40 ft
- Rotated 90°, unsupported: 6.56 ft
- Speed, gliding 16.40 ft/s
- Speed, unsupported 65.62 ft/s
- Acceleration, gliding 82.02 ft/s²
- Acceleration, unsupported 98.43 ft/s²

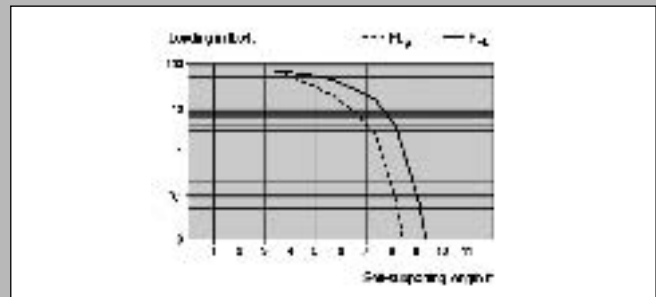

- Travel distance, gliding: 328.08 ft
- Travel distance, self-supporting: see diagram
- Travel distance, vertical, hanging: 196.85 ft
- Travel distance, vertical, upright: 16.40 ft
- Rotated 90°, unsupported: 3.28 ft
- Speed, gliding 16.40 ft/s
- Speed, unsupported 65.62 ft/s
- Acceleration, gliding 82.02 ft/s²
- Acceleration, unsupported 98.43 ft/s²

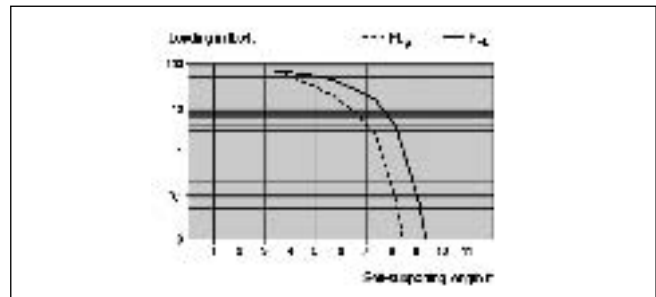

- Travel distance, gliding: 262.47 ft
- Travel distance, self-supporting: see diagram
- Travel distance, vertical, hanging: 131.23 ft
- Travel distance, vertical, upright: 9.84 ft
- Rotated 90°, unsupported: 3.28 ft
- Speed, gliding 9.84 ft/s
- Speed, unsupported 32.81 ft/s
- Acceleration, gliding 49.21 ft/s²
- Acceleration, unsupported 65.62 ft/s²

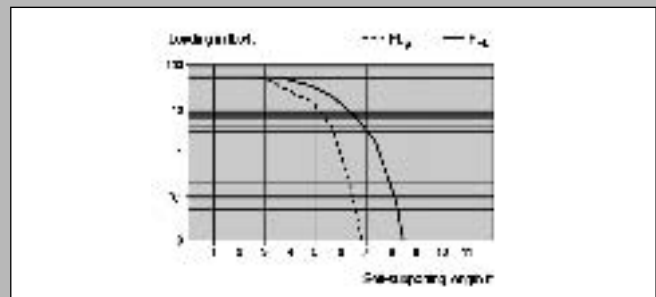

- Travel distance, gliding: 164.04 ft
- Travel distance, self-supporting: see diagram
- Travel distance, vertical, hanging: 131.23 ft
- Travel distance, vertical, upright: 9.84 ft
- Rotated 90°, unsupported: 3.28 ft
- Speed, gliding 16.40 ft/s
- Speed, unsupported 49.21 ft/s
- Acceleration, gliding 49.21 ft/s²
- Acceleration, unsupported 65.62 ft/s²

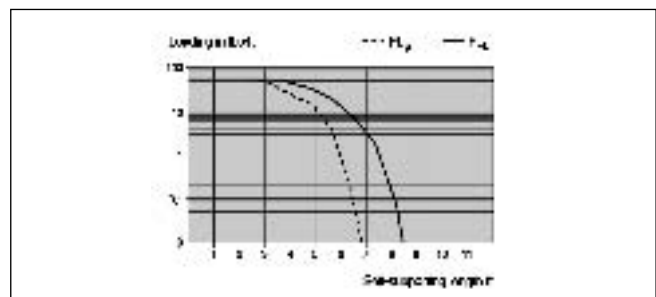



Technical data: open cable drag chains

MP 41

Page 119

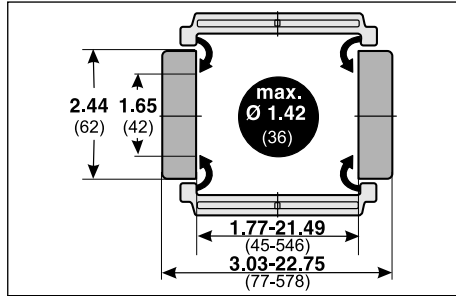

- Interior height: 1.65 in (42 mm)
- Interior widths: 1.77–21.50 in (45–546 mm)
- Radii: 3.54–11.81 in (90–300 mm)
- Pitch: 3.03 in (77 mm)
- Links per foot (meter): 4 (13) pc
- Loading side: inside and outside flexure curve
- Existing shelving system

MP 41.2

Page 131

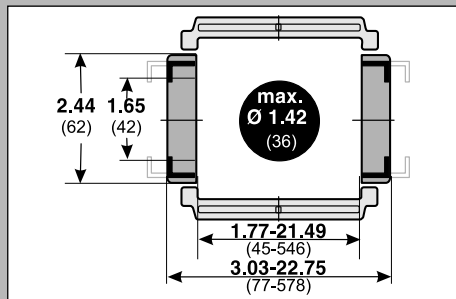

- Interior height: 1.65 in (42 mm)
- Interior widths: 1.77–21.50 in (45–546 mm)
- Radii: 3.54–11.81 in (90–300 mm)
- Pitch: 3.03 in (77 mm)
- Links per foot (meter): 4 (13) pc
- Loading side: inside and outside flexure curve
- Existing shelving system

MP 52.1

Page 143

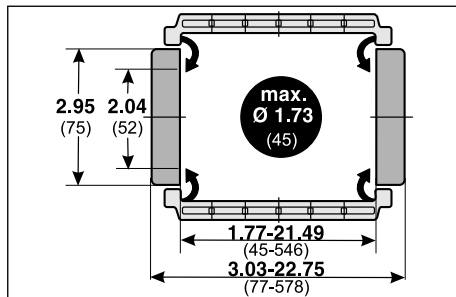

- Interior height: 2.05 in (52 mm)
- Interior widths: 1.77–21.50 in (45–546 mm)
- Radii: 3.94–13.78 in (100–350 mm)
- Pitch: 3.58 in (91 mm)
- Links per foot (meter): 4 (11) pc
- Loading side: inside and outside flexure curve
- Existing shelving system

MP 52.2

Page 155

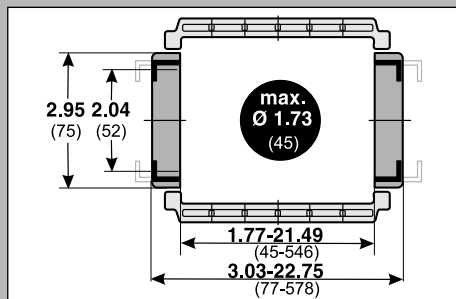

- Interior height: 2.05 in (52 mm)
- Interior widths: 1.77–21.50 in (45–546 mm)
- Radii: 3.94–13.78 in (100–350 mm)
- Pitch: 3.58 in (91 mm)
- Links per foot (meter): 4 (11) pc
- Loading side: inside and outside flexure curve
- Existing shelving system

MP 66

Page 169

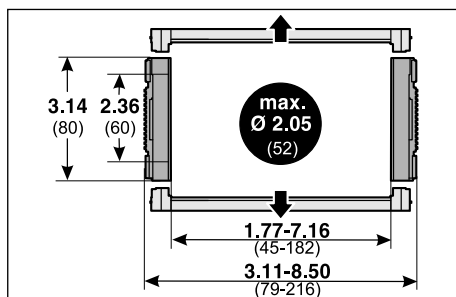

- Interior height: 2.36 in (60 mm)
- Interior widths: 1.77–7.17 in (45–182 mm)
- Radii: 5.91–13.78 in (150–350 mm)
- Pitch: 3.60 in (91,5 mm)
- Links per foot (meter): 4 (11) pc
- Loading side: inside and outside flexure curve
- Existing shelving system

- Travel distance, gliding: 393.70 ft
- Travel distance, self-supporting: see diagram
- Travel distance, vertical, hanging: 328.08 ft
- Travel distance, vertical, upright: 19.69 ft
- Rotated 90°, unsupported: 6.56 ft
- Speed, gliding 16.40 ft/s
- Speed, unsupported 65.62 ft/s
- Acceleration, gliding 82.02 ft/s²
- Acceleration, unsupported 98.43 ft/s²

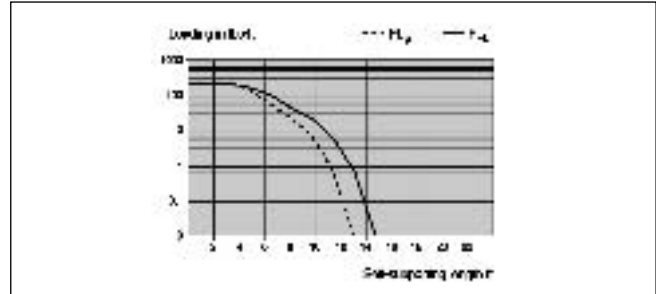

- Travel distance, gliding: 393.70 ft
- Travel distance, self-supporting: see diagram
- Travel distance, vertical, hanging: 328.08 ft
- Travel distance, vertical, upright: 19.69 ft
- Rotated 90°, unsupported: 3.28 ft
- Speed, gliding 16.40 ft/s
- Speed, unsupported 65.62 ft/s
- Acceleration, gliding 82.02 ft/s²
- Acceleration, unsupported 98.43 ft/s²

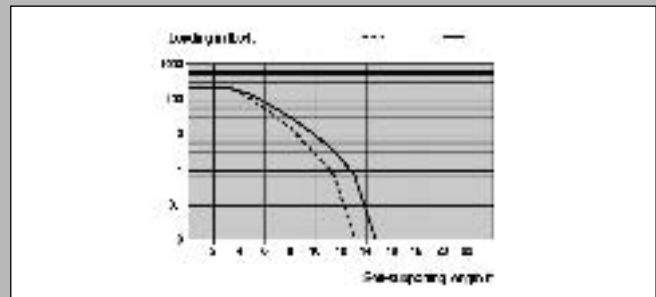

- Travel distance, gliding: 492.13 ft
- Travel distance, self-supporting: see diagram
- Travel distance, vertical, hanging: 328.08 ft
- Travel distance, vertical, upright: 19.69 ft
- Rotated 90°, unsupported: 9.84 ft
- Speed, gliding 16.40 ft/s
- Speed, unsupported 65.62 ft/s
- Acceleration, gliding 82.02 ft/s²
- Acceleration, unsupported 98.43 ft/s²

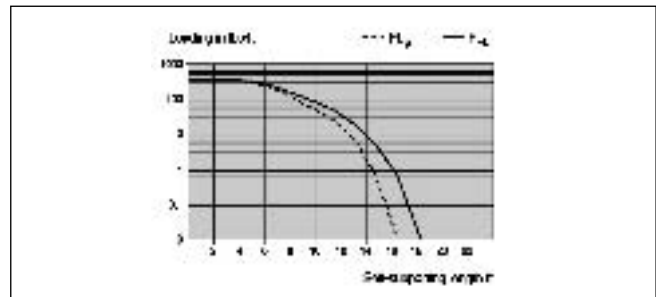

- Travel distance, gliding: 492.13 ft
- Travel distance, self-supporting: see diagram
- Travel distance, vertical, hanging: 328.08 ft
- Travel distance, vertical, upright: 19.69 ft
- Rotated 90°, unsupported: 6.56 ft
- Speed, gliding 16.40 ft/s
- Speed, unsupported 65.62 ft/s
- Acceleration, gliding 82.02 ft/s²
- Acceleration, unsupported 98.43 ft/s²

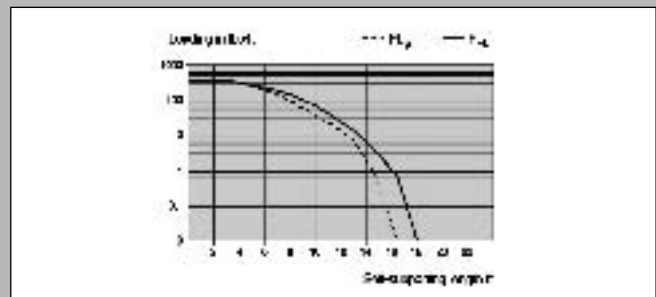

- Travel distance, gliding: 262.47 ft
- Travel distance, self-supporting: see diagram
- Travel distance, vertical, hanging: 164.04 ft
- Travel distance, vertical, upright: 16.40 ft
- Rotated 90°, unsupported: 6.56 ft
- Speed, gliding 16.40 ft/s
- Speed, unsupported 49.21 ft/s
- Acceleration, gliding 49.21 ft/s²
- Acceleration, unsupported 82.02 ft/s²

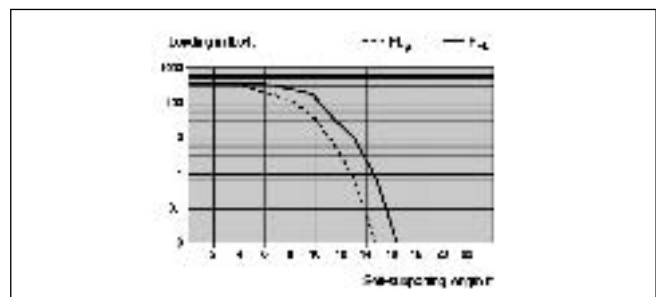



Technical data: open cable drag chains

MP 62.1

Page 177

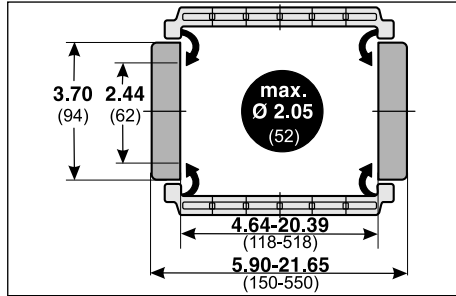

- Interior height: 2.44 in (62 mm)
- Interior widths: 4.65–20.39 in (118–518 mm)
- Radii: 5.91–19.69 in (150–500 mm)
- Pitch: 3.94 in (100 mm)
- Links per foot (meter): 3 (10) pc
- Loading side: inside and outside flexure curve
- Existing shelving system

MP 62.2

Page 189

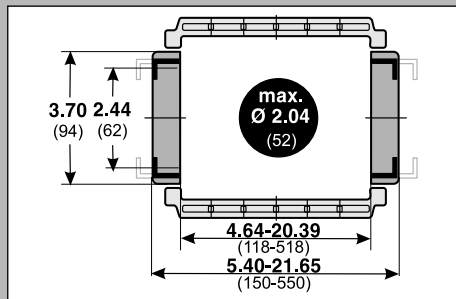

- Interior height: 2.44 in (62 mm)
- Interior widths: 4.65–20.39 in (118–518 mm)
- Radii: 5.91–19.69 in (150–500 mm)
- Pitch: 3.94 in (100 mm)
- Links per foot (meter): 3 (10) pc
- Loading side: inside and outside flexure curve
- Existing shelving system

MP 72

Page 201

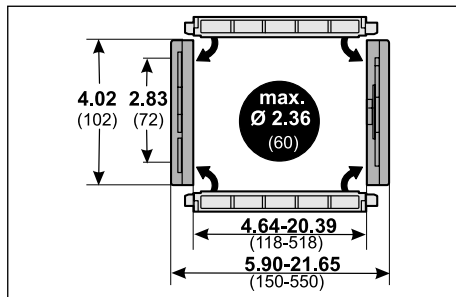

- Interior height: 2.83 in (72 mm)
- Interior widths: 4.65–20.39 in (118–518 mm)
- Radii: 5.91–19.69 in (150–500 mm)
- Pitch: 3.94 in (100 mm)
- Links per foot (meter): 3 (10) pc
- Loading side: inside and outside flexure curve
- Existing shelving system

MP 82.2

Page 213

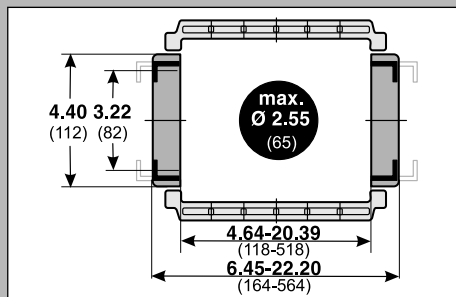

- Interior height: 3.23 in (82 mm)
- Interior widths: 4.65–20.39 in (118–518 mm)
- Radii: 5.91–19.69 in (150–500 mm)
- Pitch: 4.65 in (118 mm)
- Links per foot (meter): 3 (9) pc
- Loading side: inside and outside flexure curve
- Existing shelving system

MP 102.2

Page 223

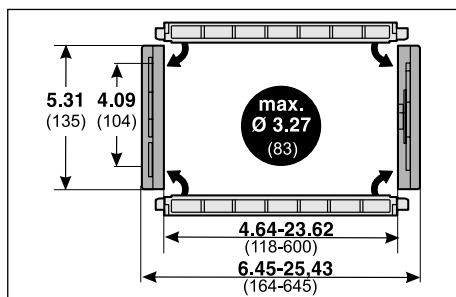

- Interior height: 4.09 in (104 mm)
- Interior widths: 4.65–20.39 in (118–518 mm)
- Radii: 9.84–19.69 in (250–500 mm)
- Pitch: 5.55 in (141 mm)
- Links per foot (meter): 2 (7) pc
- Loading side: inside and outside flexure curve
- Existing shelving system

- Travel distance, gliding: 492.13 ft
- Travel distance, self-supporting: see diagram
- Travel distance, vertical, hanging: 393.70 ft
- Travel distance, vertical, upright: 19.69 ft
- Rotated 90°, unsupported: 13.12 ft
- Speed, gliding 16.40 ft/s
- Speed, unsupported 65.62 ft/s
- Acceleration, gliding 82.02 ft/s²
- Acceleration, unsupported 131.23 ft/s²

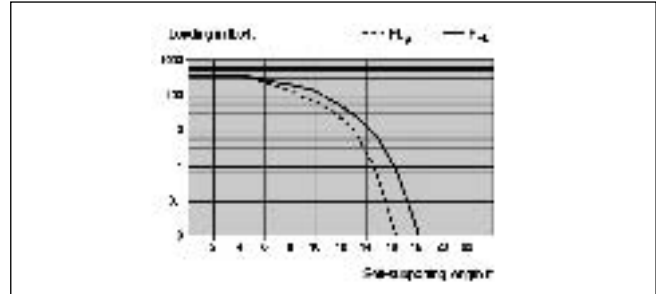

- Travel distance, gliding: 492.13 ft
- Travel distance, self-supporting: see diagram
- Travel distance, vertical, hanging: 393.70 ft
- Travel distance, vertical, upright: 19.69 ft
- Rotated 90°, unsupported: 13.12 ft
- Speed, gliding 16.40 ft/s
- Speed, unsupported 65.62 ft/s
- Acceleration, gliding 82.02 ft/s²
- Acceleration, unsupported 131.23 ft/s²

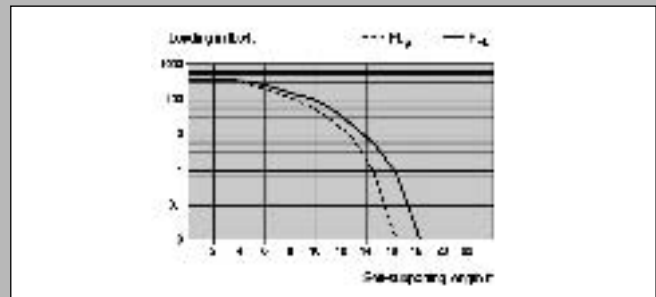

- Travel distance, gliding: 492.13 ft
- Travel distance, self-supporting: see diagram
- Travel distance, vertical, hanging: 393.70 ft
- Travel distance, vertical, upright: 19.69 ft
- Rotated 90°, unsupported: 19.69 ft
- Speed, gliding 16.40 ft/s
- Speed, unsupported 65.62 ft/s
- Acceleration, gliding 82.02 ft/s²
- Acceleration, unsupported 131.23 ft/s²

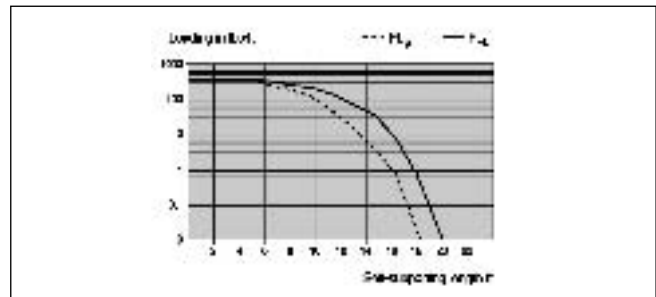

- Travel distance, gliding: 492.13 ft
- Travel distance, self-supporting: see diagram
- Travel distance, vertical, hanging: 393.70 ft
- Travel distance, vertical, upright: 19.69 ft
- Rotated 90°, unsupported: 9.84 ft
- Speed, gliding 16.40 ft/s
- Speed, unsupported 65.62 ft/s
- Acceleration, gliding 82.02 ft/s²
- Acceleration, unsupported 131.23 ft/s²

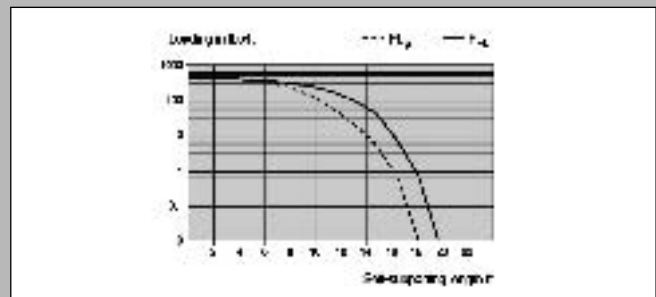

- Travel distance, gliding: 492.13 ft
- Travel distance, self-supporting: see diagram
- Travel distance, vertical, hanging: 492.13 ft
- Travel distance, vertical, upright: 26.25 ft
- Rotated 90°, unsupported: 26.25 ft
- Speed, gliding 16.40 ft/s
- Speed, unsupported 65.62 ft/s
- Acceleration, gliding 82.02 ft/s²
- Acceleration, unsupported 131.23 ft/s²

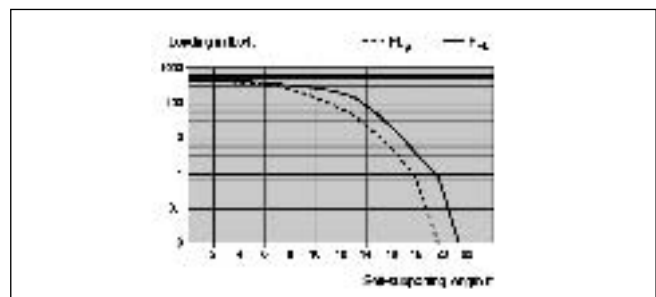



Technical data: closed cable drag chains

MP 25 G

Page 235

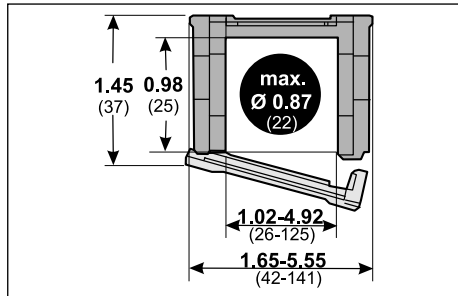

- Interior height: 0.98 in (25 mm)
- Interior widths: 1.02–4.92 in (26–125 mm)
- Radii: 2.36–9.84 in (60–250 mm)
- Pitch: 1.18 in (30 mm)
- Links per foot (meter): 11 (33) pc
- Loading side: outside flexure curve
- Existing shelving system

MP 32.3 G

Page 241

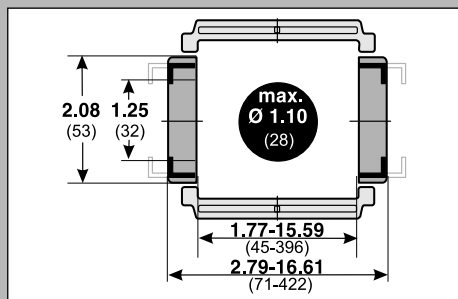

- Interior height: 1.26 in (32 mm)
- Interior widths: 1.77–15.59 in (45–396 mm)
- Radii: 4.72–9.84 in (120–250 mm)
- Pitch: 2.54 in (64,5 mm)
- Links per foot (meter): 5 (16) pc
- Loading side: inside and outside flexure curve
- Existing shelving system

MP 36 G

Page 253

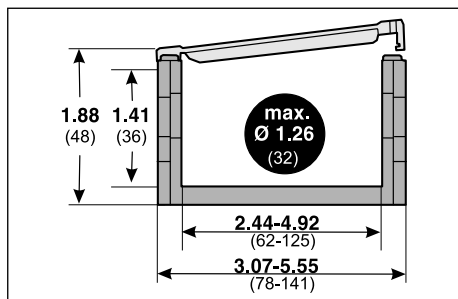

- Interior height: 1.42 in (36 mm)
- Interior widths: 2.44–4.92 in (62–125 mm)
- Radii: 3.15–7.87 in (80–200 mm)
- Pitch: 1.57 in (40 mm)
- Links per foot (meter): 8 (25) pc
- Loading side: inside flexure curve
- Existing shelving system

MP 43 G

Page 261

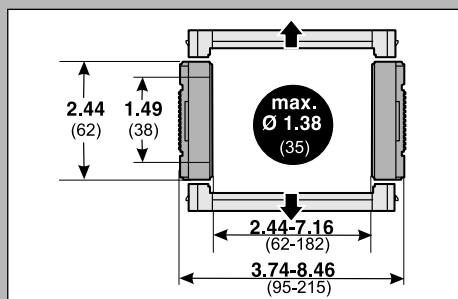

- Interior height: 1.50 in (38 mm)
- Interior widths: 2.44–7.17 in (62–182 mm)
- Radii: 4.92–9.84 in (125–250 mm)
- Pitch: 2.97 in (75,5 mm)
- Links per foot (meter): 4 (13) pc
- Loading side: inside and outside flexure curve
- Existing shelving system

MP 41.3 G

Page 267

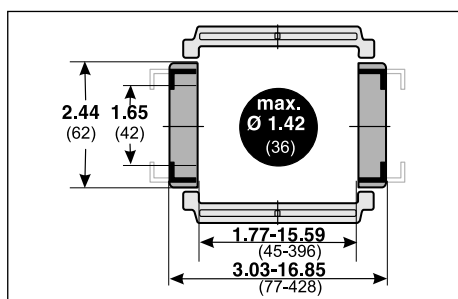

- Interior height: 1.65 in (42 mm)
- Interior widths: 1.77–15.59 in (45–396 mm)
- Radii: 5.91–11.81 in (150–300 mm)
- Pitch: 3.03 in (77,0 mm)
- Links per foot (meter): 4 (13) pc
- Loading side: inside and outside flexure curve
- Existing shelving system

- Travel distance, gliding: 131.23 ft
- Travel distance, self-supporting: see diagram
- Travel distance, vertical, hanging: 82.02 ft
- Travel distance, vertical, upright: 9.84 ft
- Rotated 90°, unsupported: 3.28 ft
- Speed, gliding 9.84 ft/s
- Speed, unsupported 19.69 ft/s
- Acceleration, gliding 32.81 ft/s²
- Acceleration, unsupported 49.21 ft/s²

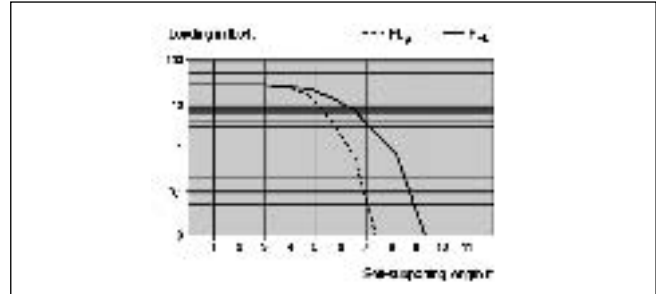

- Travel distance, gliding: 328.08 ft
- Travel distance, self-supporting: see diagram
- Travel distance, vertical, hanging: 196.85 ft
- Travel distance, vertical, upright: 16.40 ft
- Rotated 90°, unsupported: 3.28 ft
- Speed, gliding 16.40 ft/s
- Speed, unsupported 65.62 ft/s
- Acceleration, gliding 82.02 ft/s²
- Acceleration, unsupported 98.43 ft/s²

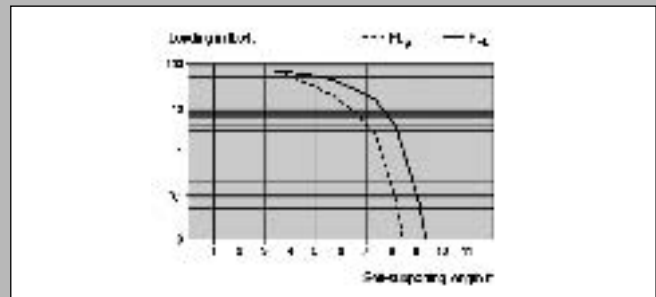

- Travel distance, gliding: 196.85 ft
- Travel distance, self-supporting: see diagram
- Travel distance, vertical, hanging: 98.43 ft
- Travel distance, vertical, upright: 9.84 ft
- Rotated 90°, unsupported: 3.28 ft
- Speed, gliding 9.84 ft/s
- Speed, unsupported 32.81 ft/s
- Acceleration, gliding 49.21 ft/s²
- Acceleration, unsupported 65.62 ft/s²

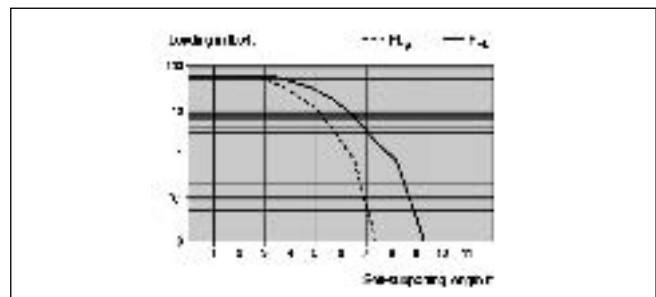

- Travel distance, gliding: 164.04 ft
- Travel distance, self-supporting: see diagram
- Travel distance, vertical, hanging: 131.23 ft
- Travel distance, vertical, upright: 9.84 ft
- Rotated 90°, unsupported: 3.28 ft
- Speed, gliding 16.40 ft/s
- Speed, unsupported 49.21 ft/s
- Acceleration, gliding 49.21 ft/s²
- Acceleration, unsupported 65.62 ft/s²

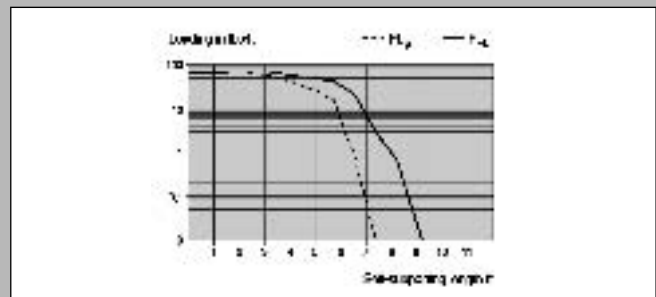

- Travel distance, gliding: 393.70 ft
- Travel distance, self-supporting: see diagram
- Travel distance, vertical, hanging: 328.08 ft
- Travel distance, vertical, upright: 19.69 ft
- Rotated 90°, unsupported: 3.28 ft
- Speed, gliding 16.40 ft/s
- Speed, unsupported 65.62 ft/s
- Acceleration, gliding 82.02 ft/s²
- Acceleration, unsupported 98.43 ft/s²

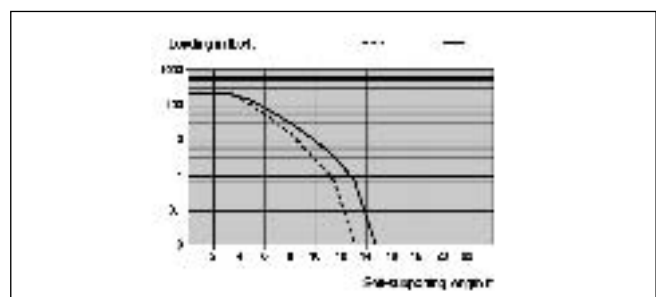



Technical data: closed cable drag chains

MP 52.3 G

Page 281

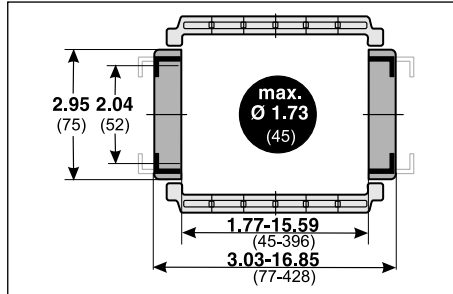

- Interior height: 2.05 in (52 mm)
- Interior widths: 1.77–15.59 in (45–396 mm)
- Radii: 5.91–13.78 in (150–350 mm)
- Pitch: 3.58 in (91,0 mm)
- Links per foot (meter): 4 (11) pc
- Loading side: inside and outside flexure curve
- Existing shelving system

MP 65 G

Page 295

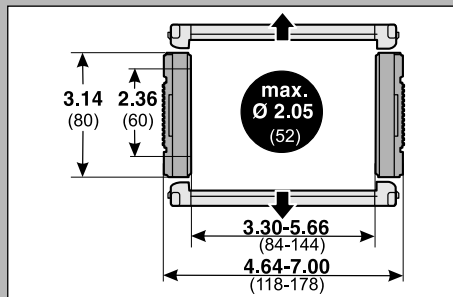

- Interior height: 2.36 in (60 mm)
- Interior widths: 3.31–5.67 in (84–144 mm)
- Radii: 7.87–11.81 in (200–350 mm)
- Pitch: 3.60 in (91,5 mm)
- Links per foot (meter): 3 (11) pc
- Loading side: inside and outside flexure curve
- Existing shelving system

MP 62.3 G

Page 303

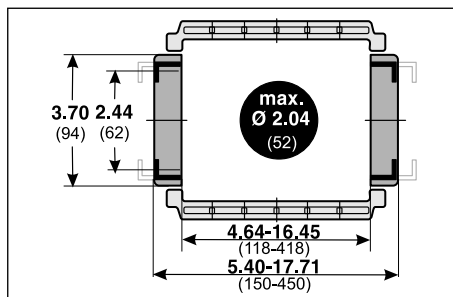

- Interior height: 2.44 in (62 mm)
- Interior widths: 4.65–16.46 in (118–418 mm)
- Radii: 7.87–19.69 in (200–500 mm)
- Pitch: 3.94 in (100,0 mm)
- Links per foot (meter): 3 (10) pc
- Loading side: inside and outside flexure curve
- Existing shelving system

MP 82.3 G

Page 315

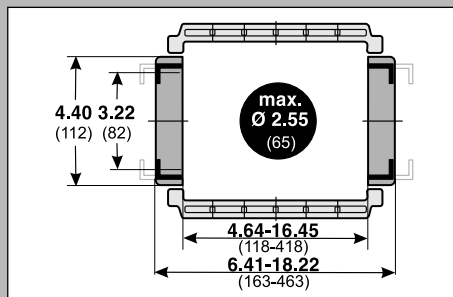

- Interior height: 3.23 in (82 mm)
- Interior widths: 4.65–16.46 in (118–418 mm)
- Radii: 7.87–19.69 in (200–500 mm)
- Pitch: 4.65 in (118,0 mm)
- Links per foot (meter): 3 (9) pc
- Loading side: inside and outside flexure curve
- Existing shelving system

- Travel distance, gliding: 492.13 ft
- Travel distance, self-supporting: see diagram
- Travel distance, vertical, hanging: 328.08 ft
- Travel distance, vertical, upright: 19.69 ft
- Rotated 90°, unsupported: 9.84 ft
- Speed, gliding 16.40 ft/s
- Speed, unsupported 65.62 ft/s
- Acceleration, gliding 82.02 ft/s²
- Acceleration, unsupported 98.43 ft/s²

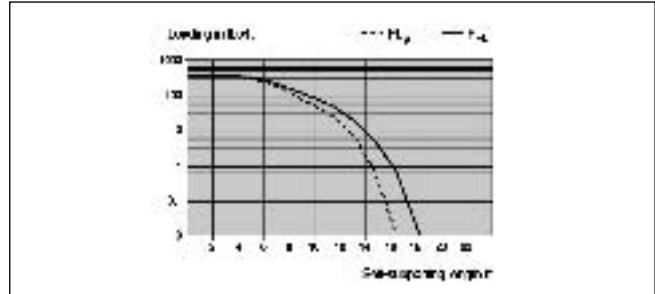

- Travel distance, gliding: 196.85 ft
- Travel distance, self-supporting: see diagram
- Travel distance, vertical, hanging: 164.04 ft
- Travel distance, vertical, upright: 16.40 ft
- Rotated 90°, unsupported: 6.56 ft
- Speed, gliding 16.40 ft/s
- Speed, unsupported 49.21 ft/s
- Acceleration, gliding 49.21 ft/s²
- Acceleration, unsupported 82.02 ft/s²

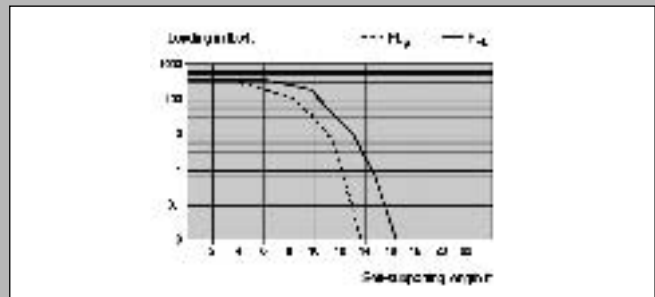

- Travel distance, gliding: 492.13 ft
- Travel distance, self-supporting: see diagram
- Travel distance, vertical, hanging: 393.70 ft
- Travel distance, vertical, upright: 19.69 ft
- Rotated 90°, unsupported: 6.56 ft
- Speed, gliding 16.40 ft/s
- Speed, unsupported 65.62 ft/s
- Acceleration, gliding 82.02 ft/s²
- Acceleration, unsupported 131.23 ft/s²

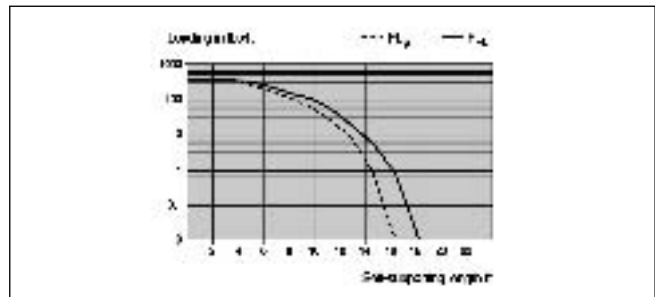

- Travel distance, gliding: 492.13 ft
- Travel distance, self-supporting: see diagram
- Travel distance, vertical, hanging: 393.70 ft
- Travel distance, vertical, upright: 19.69 ft
- Rotated 90°, unsupported: 9.84 ft
- Speed, gliding 16.40 ft/s
- Speed, unsupported 65.62 ft/s
- Acceleration, gliding 82.02 ft/s²
- Acceleration, unsupported 131.23 ft/s²

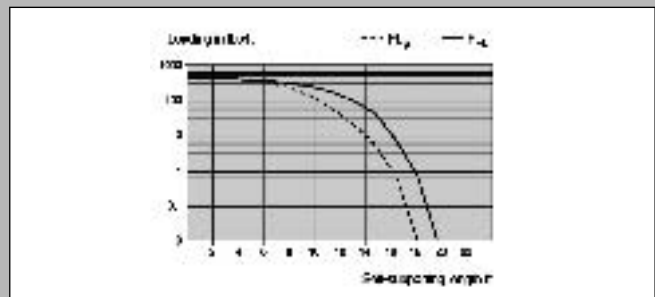



Information about ESD cable drag chains

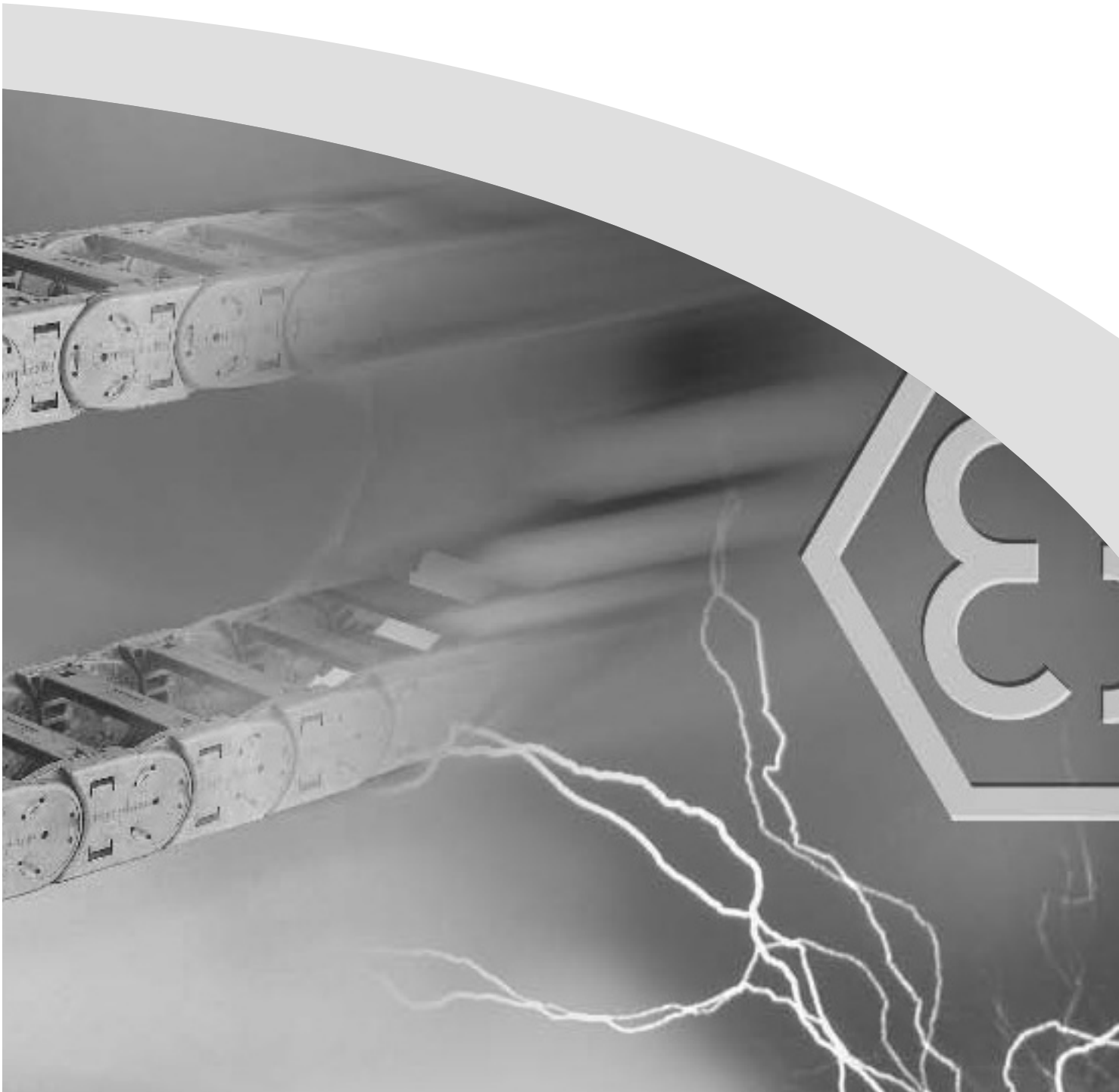

Murrplastik Systemtechnik GmbH has incorporated cable drag chain systems for use in potentially explosive locations in its delivery program. All cable drag chains and accessories of the standard delivery program may be delivered as a special range of products providing explosive protection.

Made from a special material, these cable drag chains do not accumulate charge and also have a very high derivation

ability for electrostatic charges; as such they not only meet, but largely exceed, the requirements of ATEX 94/9/EC. Starting in June 2003, all components and machines used in potentially explosive areas must be approved under the ATEX directive.

Murrplastik cable drag chains are certified as appliances which provide significant advantages for the user. In and of themselves, our products are approved components conforming to ATEX 94/9/EC, thus eliminating the need for acceptance of the entire machine.



Additional informational materials

- ATEX Operating Manual
- Info brochure ESD chains
- Usage guidelines

Please request



Choosing a cable drag chain

The layout of the cable drag chain is done by taking the following criteria into account:

- 1) The number and outside diameter of the conduits and/or cables that are to be carried.
- 2) The total weight of the cables and conduits which determines the cable drag chain type from the relevant table.
- 3) The available height and width of the assembly.
- 4) The minimum bend radius of the cables and conduits without straining them. Obtained from the manufacturer's literature.
- 5) Determine the chain length respective to the travel distance and the radius of curvature selected (see individual cable drag chain types).
- 6) In addition, check if a guide channel is necessary for guidance of the cable drag chain.

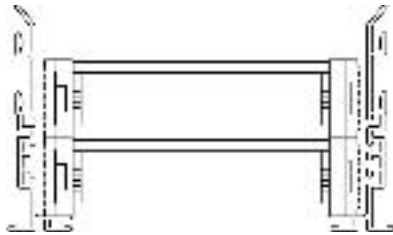

Section A-A: The cable drag chain glides on itself

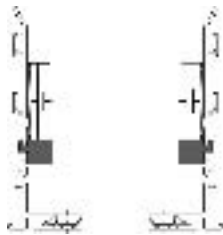

Section B-B: The cable drag chain runs on the glide rail

Self-supporting lengths and travel distances

The self-supporting length is dependent on the travel distance and on the additional load. A level stacking surface or a guide channel is required for the cable drag chain to function smoothly.

If the self-supporting length is exceeded, the chain upper run will sit on the lower run. Due to the excellent gliding properties of the plastic used, the operation is not hampered by the movement of the cable drag chain.

The use of a guide channel is recommended as a general rule.

More information on our variable guide channel systems can be found on page 325 and following.

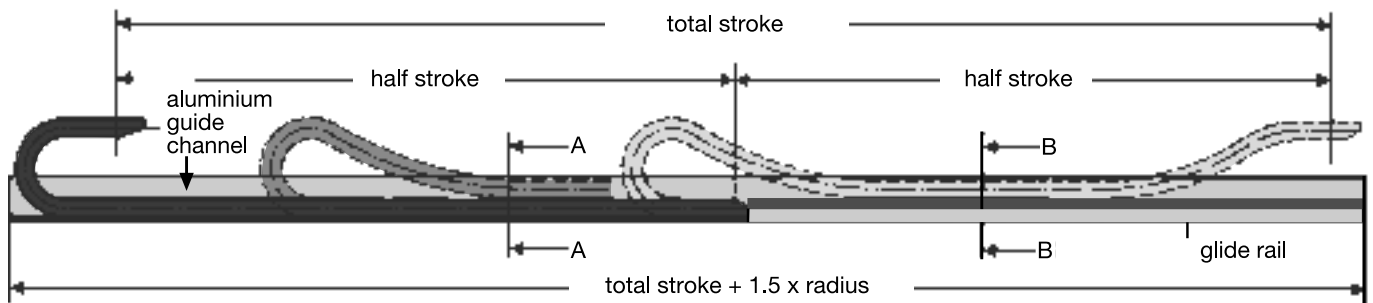

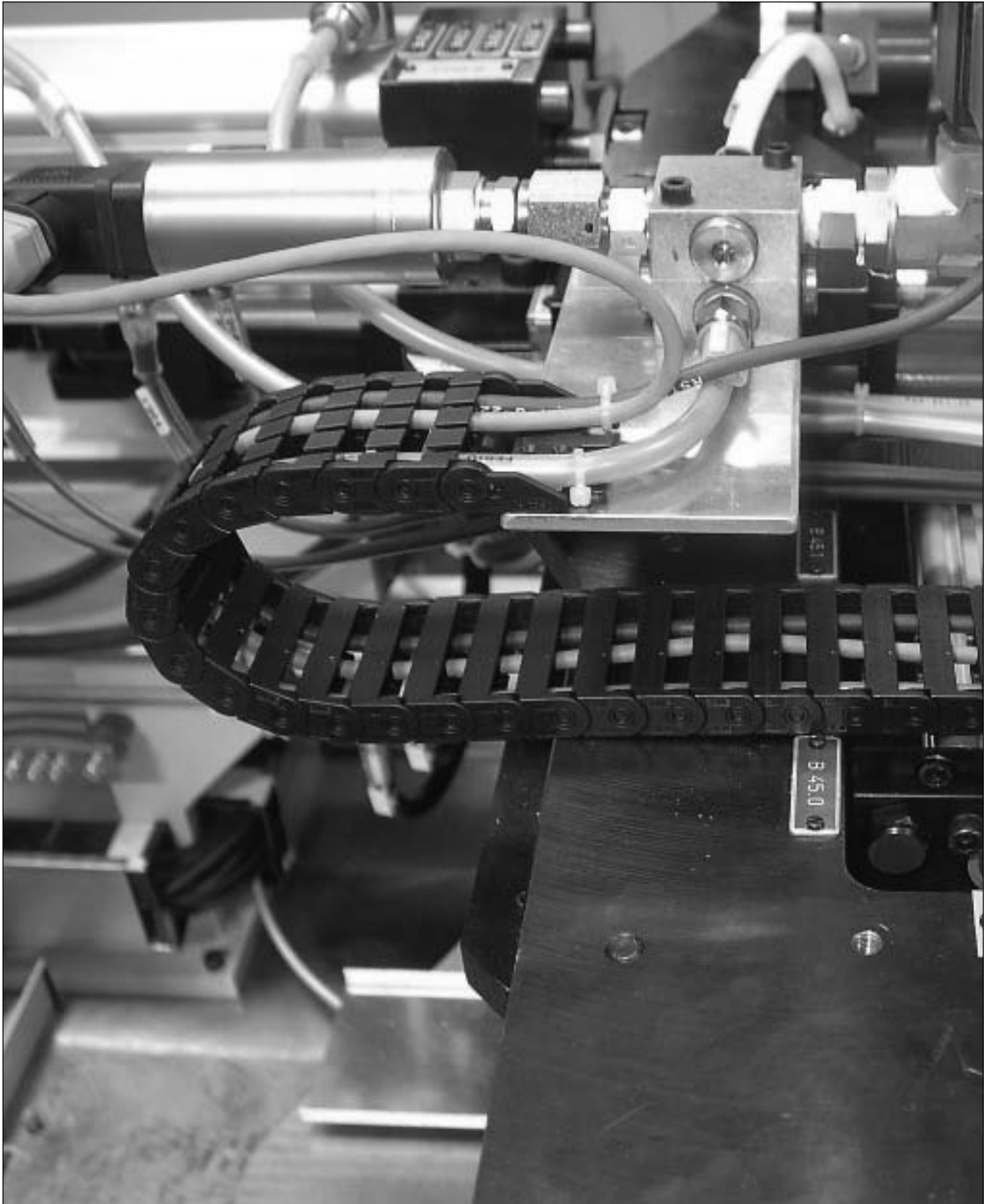



Mounting options

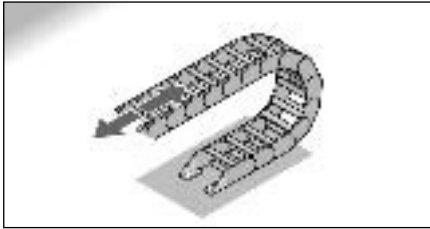

1.

Horizontal, straight self-supporting

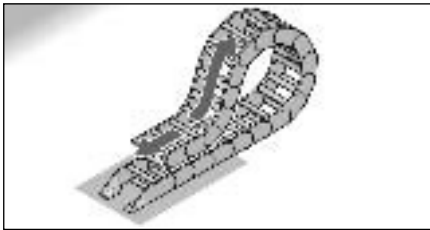

2.

Horizontal, sliding

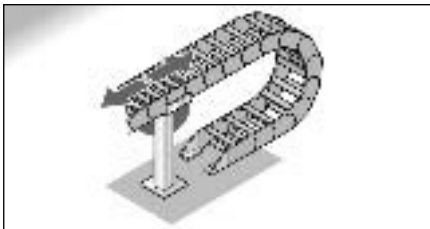

3.

Horizontal with additional support



4.

Horizontal, counter-rotating
Special type with reverse bending radius

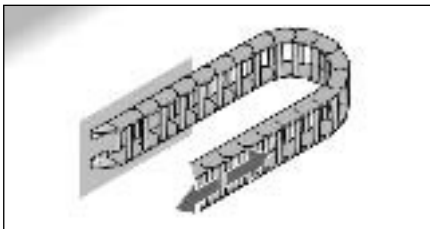

5.

Horizontal, side mounted (rotated by 90°)



6.

Horizontal, side by side

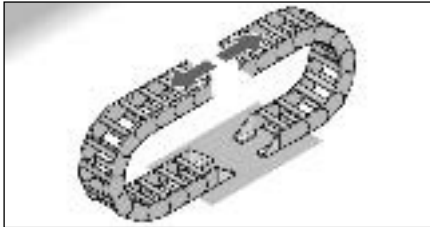

7. Horizontal, opposed



8. Vertical, standing

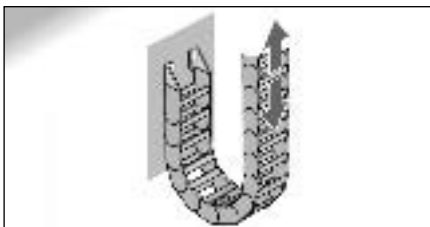

9. Vertical, hanging

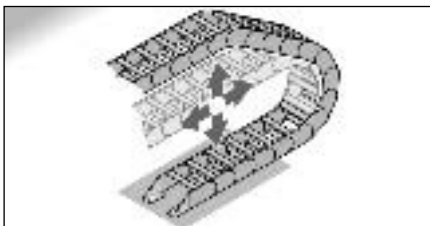

10. Combined horizontal and vertical movement

Lowered fixing point



It is sometimes necessary to lower the height of the moving attachment point.

In this case, modifications in determining the specifics of the chain must be made.



Inquiry

Order

Company:

Address/PO Box:

Zip code/City:

Department:

Contact person:

Industry:

Tel. extension:

Fax:

Date:

Application parameters

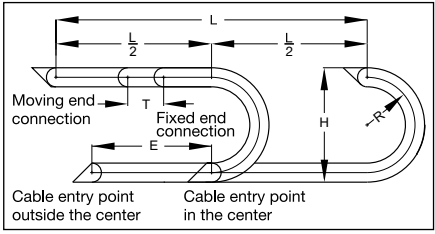

L = Travel distance,
R = Radius,
H = Installation height,
T = Pitch,
E = Distance of entry point
to center of travel distance

Mounting options

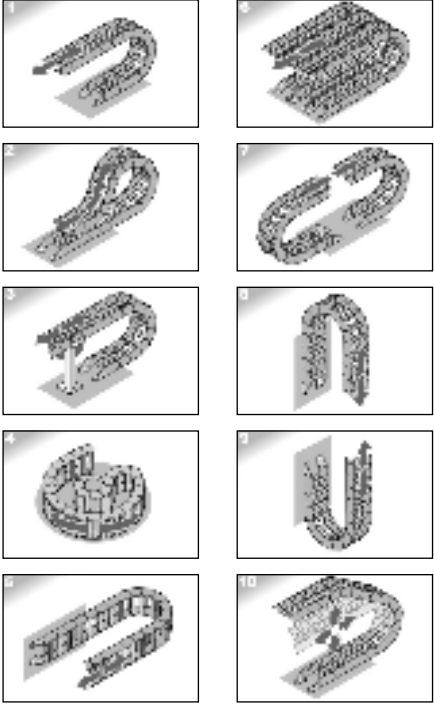

Travel distance: _____ ft
 Speed of travel: _____ ft/s
 Acceleration: _____ ft/s²
 Travel frequency: _____ x/h
 Items carried: _____ see appendix
 Max. installation width: _____ inch
 Max. installation height: _____ inch
 Entry point: _____ center of stroke
 _____ ends of stroke

... .. m from the center of the
travel distance

Type of installation (see on right): _____
 Environmental influences: _____
 Ambient temperature: _____
 Guide channel available: _____
 If so, state internal width _____ yes no
 If so, state inside height _____ inch
 Chain bracket (see on right) _____ inch
 Moving end connection
 Fixed connection

Chain bracket

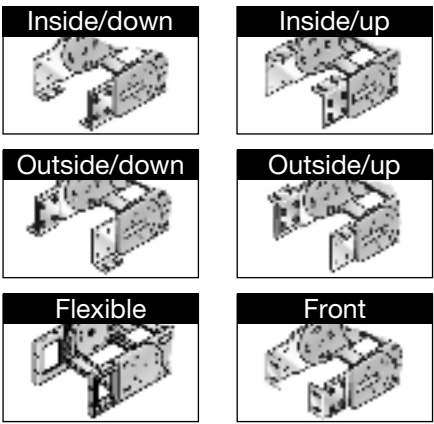

Number of cable drag chain systems: _____ pieces



Items to be carried:

Supply	No. of cables (pcs.)	Manufacturer	Type	Diameter in inch	Weight in kg/m	Minimum bending radius in inch	Cables with plugs and sockets attached
fiber optic							<input type="checkbox"/> yes <input type="checkbox"/> no
hydraulic							<input type="checkbox"/> yes <input type="checkbox"/> no
pneumatic							<input type="checkbox"/> yes <input type="checkbox"/> no
electric							<input type="checkbox"/> yes <input type="checkbox"/> no
Water							<input type="checkbox"/> yes <input type="checkbox"/> no
.....							<input type="checkbox"/> yes <input type="checkbox"/> no

Cable drag chain systems

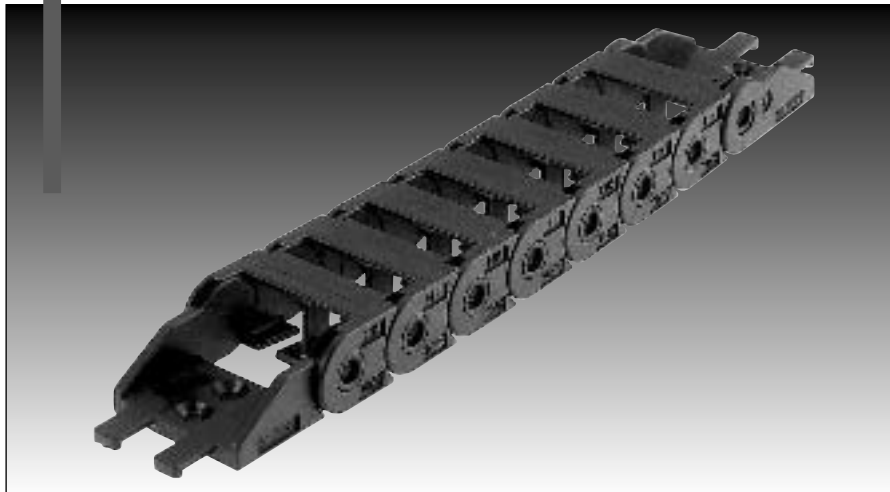

EasyLine

MP 10.1



MP 10.1 - EasyLine

Order variants

Style (order code)						
Configuration (order code)						
Radius (order code) <small>The radii can be combined with any internal width</small>						
in inch						
Internal width (order code)						
in inch						
Outside width (order code)						
in inch						
MP 10.1 006	0.51	0.24	006			
MP 10.1 009	0.63	0.35	009	0.71	018	
MP 10.1 015	0.87	0.59	015	1.10	028	0
MP 10.1 021	1.10	0.83	021	1.50	038	1
MP 10.1 031	1.50	1.22	031	1.89	048	7
MP 10.1 041	1.89	1.61	041	2.28	058	9
						0

Order-Number:

Configuration:

0 PA crossbar every link; w/bias

Style:

0 Standard (PA/black)
 1 UL94/V0 (PA/oxide red)
 7 ESD (PA/light gray)
 9 Custom version

Sample order:

0101 006 018 0000

Internal width = 0.24 in (6 mm)
 Radius = 0.71 in (18 mm)
 Configuration = 0
 Style = 0

Ideal operating conditions:







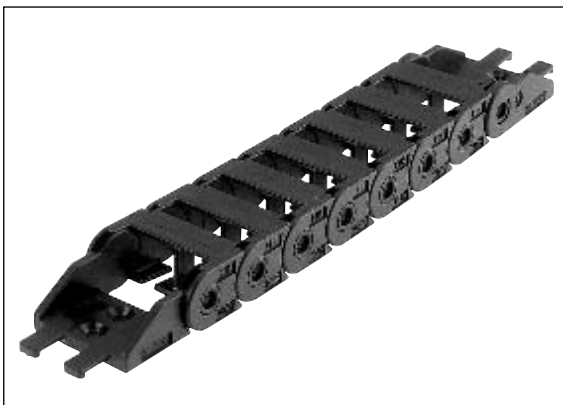

- EASY mechanism for simple filling
- Quiet operation
- Unsupported arrangement
- Gliding arrangement

Alternative chain type:

- MP 14/MP 15 Greater self-supporting lengths
- MP 14/MP 15 Higher level of stiffness and torsional strength

Features



-  Radii with medium bias (R) for all applications
-  Cable insertion aide to simplify loading of EasyLine
-  Permanently integrated separators for safe cable guidance
-  ESD cable drag chains for use in areas of electrostatic discharge
-  ESD cable drag chains for use in areas at risk of explosion
-  EASY opening mechanism for easy loading
-  Chain bracket with integrated strain relief
-  UL version in oxide red, classification V0

Technical data

Chain link dimensions (inch) (mm)

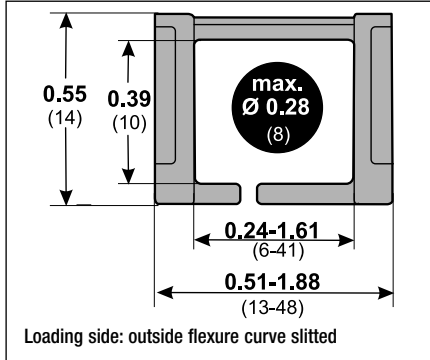

Material characteristics standard (PA/black)

Operating temperature: -22 to 248° F
 Gliding friction factor: 0.30
 Static friction factor: 0.45
 Fire classification: Based on UL94 HB

Other material properties on request

Technical specifications

Travel distance, gliding, L_g : 32.81 ft
 Travel distance, self-supporting, L_s : see diagram
 Travel distance, vertical, hanging, L_{vh} : 6.56 ft
 Travel distance, vertical, upright, L_{vu} : 3.28 ft
 Rotated 90°, self-supporting, L_{90r} : not recommended
 Speed, gliding, V_g : 6.56 ft/s
 Speed, self-supporting, V_s : 13.12 ft/s
 Acceleration, gliding, a_g : 6.56 ft/s²
 Acceleration, self-supporting, a_s : 6.56 ft/s²

Self-supporting length

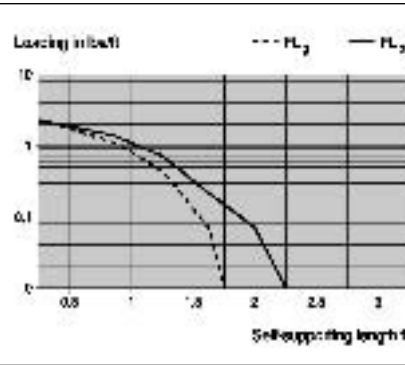
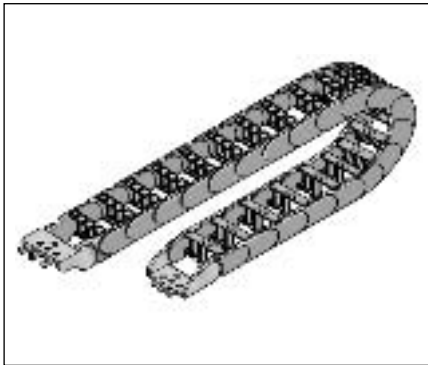

FL₁:
 Ideal installation situation for high stresses at the limit of the max. travel parameters. In this range the chain upper run is still biased, straight or has a max. sag of 0.39 – 1.97 in (10 – 50 mm) depending on the type of chain.

FL₂:
 Satisfactory installation position for many applications working in the lower to middle range of the max. travel parameters. Depending on the chain type, the sag of the chain upper run is >0.39 – 1.97 in (>10 – 50 mm) but certainly less than the max. sag.

If the sag is greater than FL₂, the arrangement is unsuitable and should be avoided. Please choose a more stable Murrplastik cable drag chain.

Determining the chain length

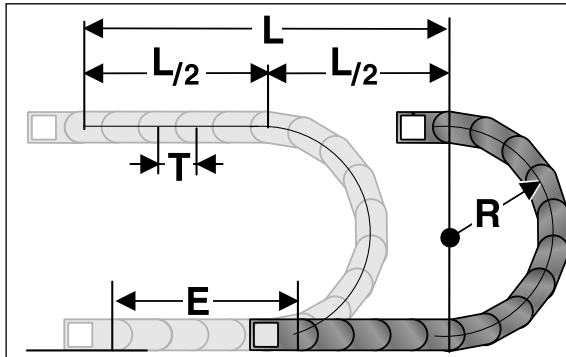

L = Travel distance
 R = Radius
 T = Pitch
 E = Distance between entry point and middle of travel distance

Determining the chain length

$$\text{Length} = \frac{L}{2} + \pi \times R + 2 \times T + E$$

≈ 1 ft(m) chain = 21(67) links each 0.59 in (15 mm)

The fixed point of the cable drag chain should be connected in the middle of the travel distance. This arrangement gives the shortest connection between the fixed point and the moving point and thus the most efficient chain length.

Installation dimensions (in inch)

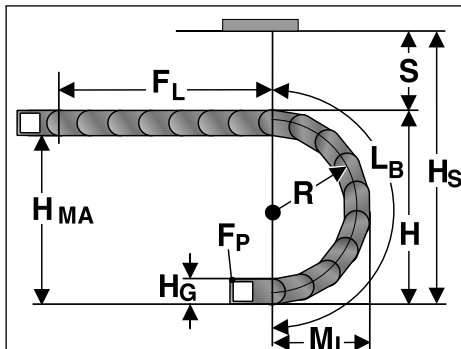

Radius R	0.71	1.10	1.50	1.89	2.28
Outside height of chain link (H_o)	0.55	0.55	0.55	0.55	0.55
Height of bend (H)	1.97	2.76	3.54	4.33	5.12
Height of moving end connection (H_{ma})	1.42	2.20	2.99	3.78	4.57
Safety margin (S)	0.39	0.39	0.39	0.39	0.39
Installation height (H_s)	2.36	3.15	3.94	4.72	5.51
Arc projection (M_L)	1.57	1.97	2.36	2.76	3.15
Bend length (L_b)	3.70	4.92	6.14	7.40	8.62



Chain bracket

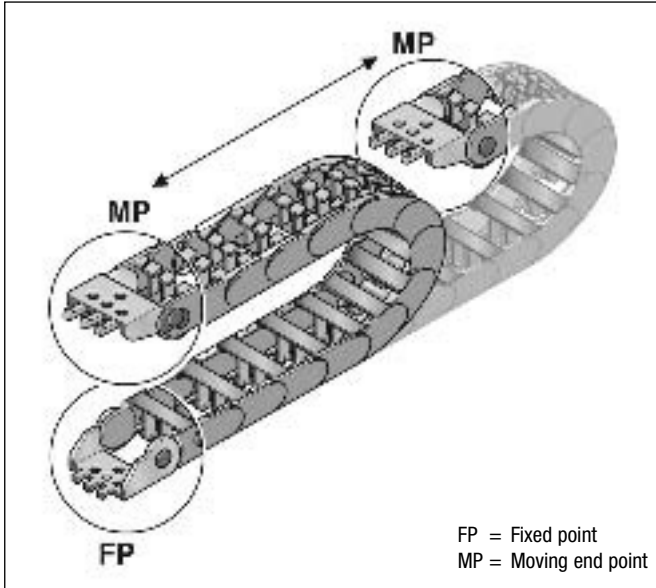

Chain bracket

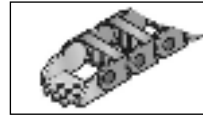

Bottom

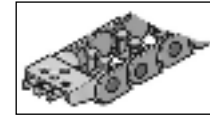

Top

Chain bracket

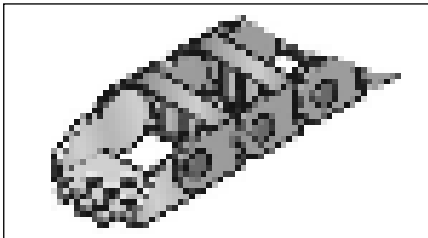

KA 10.1...

Type	Order no.	Pack qty.
KA 10.1 006 Female end	010100005000	1
KA 10.1 006 Male end	010100005100	1
KA 10.1 009 Female end	010100005200	1
KA 10.1 009 Male end	010100005300	1
KA 10.1 015 Female end	010100005400	1
KA 10.1 015 Male end	010100005500	1
KA 10.1 021 Female end	010100005600	1
KA 10.1 021 Male end	010100005700	1
KA 10.1 031 Female end	010100005800	1
KA 10.1 031 Male end	010100005900	1
KA 10.1 041 Female end	010100006000	1
KA 10.1 041 Male end	010100006100	1

The chain bracket is a fully plastic part. The bracket is precisely adjusted to the respective chain width and only needs to be snapped in at the chain link. Please order one male and one female end bracket for each chain. The brackets should be fastened with M3 screws. The cables or conduits may be fastened with cable ties on the integrated strain relief of the chain bracket.

Chain bracket

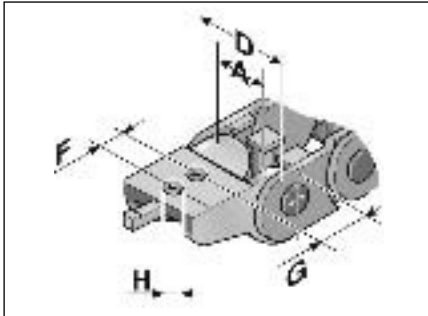

KA 10.1 006-021

Type	A inch	D inch	F inch	G inch	H Ø inch
KA 10.1 006	0.24	0.53	0.31	0.43	0.13
KA 10.1 009	0.35	0.65	0.31	0.43	0.13
KA 10.1 015	0.59	0.89	0.31	0.43	0.13
KA 10.1 021	0.83	1.12	0.31	0.43	0.13

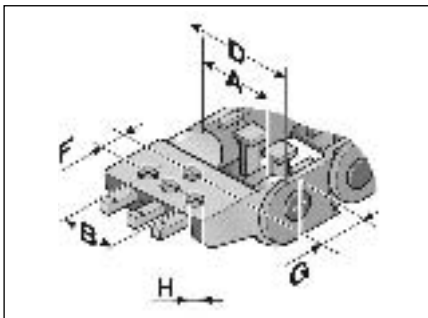

KA 10.1 031-041

Type	A inch	B inch	D inch	F inch	G inch	H Ø inch
KA 10.1 031	1.22	0.87	1.52	0.31	0.43	0.13
KA 10.1 041	1.61	1.26	1.91	0.31	0.43	0.13

Chamber size MP10.1

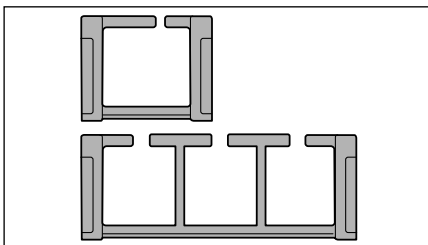

Chamber size

Type	Number of chambers	Chamber width inch
10.1 006	1	0.26
10.1 009	1	0.37
10.1 015	1	0.61
10.1 021	2	0.37
10.1 031	3	0.37
10.1 041	4	0.35

Wire insertion aid



Type	Order no.	Designation	Pack qty.
KE	83729010	Wire insertion aid KE	1

The wire insertion tool allows for quick and simple installation of cables and hoses into the cable drag chain.



MP 10.1 - Accessories

Assembly

Disassembly

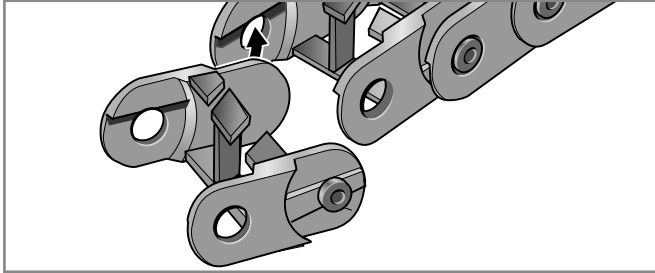

Step 1

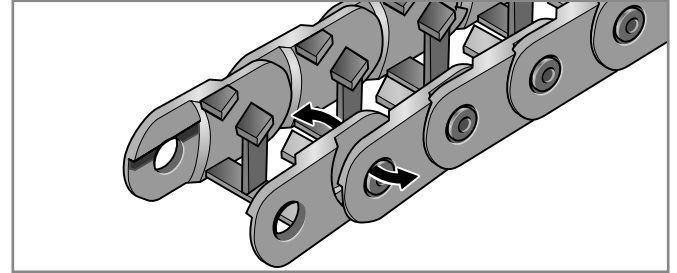

Step 1

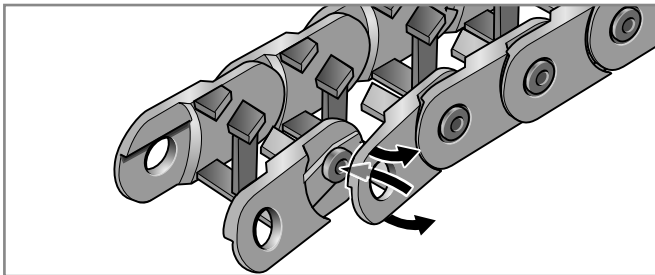

Step 2

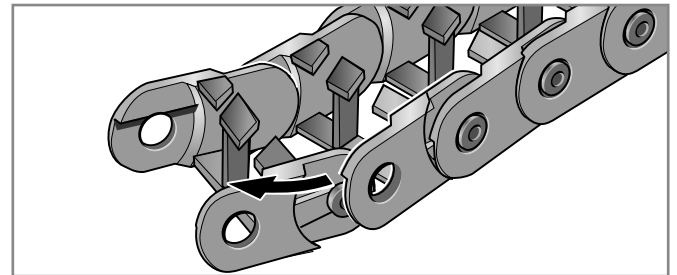

Step 2

Cable drag chain systems

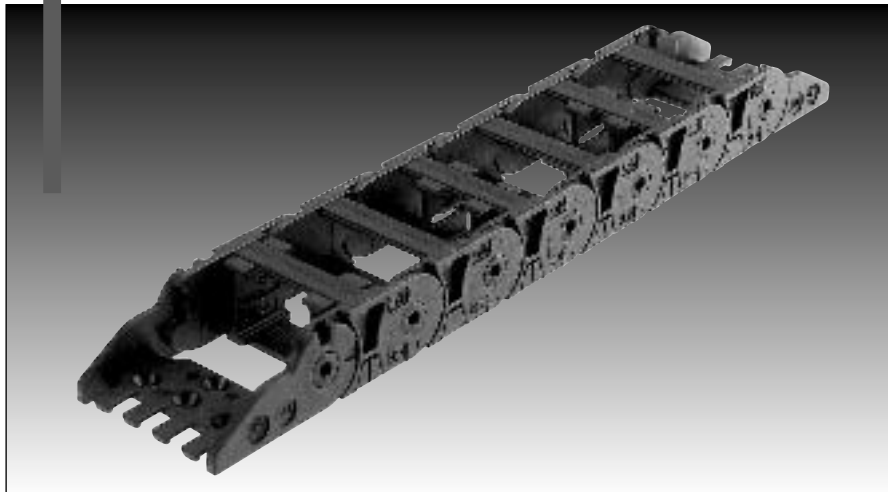

MultiLine

MP 14



MP 14 - MultiLine

Order variants

Style (order code)						
Configuration (order code)						
Radius (order code) <small>The radii can be combined with any internal width</small>						
in inch						
Internal width (order code)						
in inch						
Outside width (order code)						
in inch						
MP14 016	0.94	0.63	016	0.98	025	
MP14 020	1.10	0.79	020	1.50	038	
MP14 030	1.50	1.18	030	1.89	048	
MP14 040	1.89	1.57	040	2.95	075	
						0
						9

Order-Number:	<input type="text" value="0140"/>	<input type="text"/>	<input type="text" value="0"/>	<input type="text"/>	<input type="text" value="0"/>
----------------------	-----------------------------------	----------------------	--------------------------------	----------------------	--------------------------------

Configuration:
 0 PA crossbar every link; w/bias

Style:
 0 Standard (PA/black)
 9 Custom version

Sample order:
 0140 016 025 0000

Internal width = 0.63 (16 mm)
 Radius = 0.98 in (25 mm)
 Configuration = 0
 Style = 0

Ideal operating conditions:

- Compact dimensions with opening cover in outside bend
- Quiet operation
- Unsupported arrangement
- Gliding arrangement

Alternative chain type:

- MP 15 Higher level of stiffness and torsional strength
- MP 18. opening cover in inside bend
- MP 18.1/MP 18.2 Great self-supporting lengths

Features

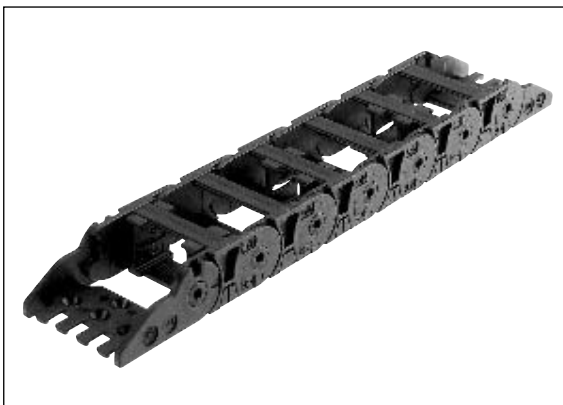

Radii with medium bias (R) for all applications



Chain bracket with integrated strain relief



Integrable separator for cable separation



Crossbars, folding on one side

Technical data

Chain link dimensions (inch) (mm)

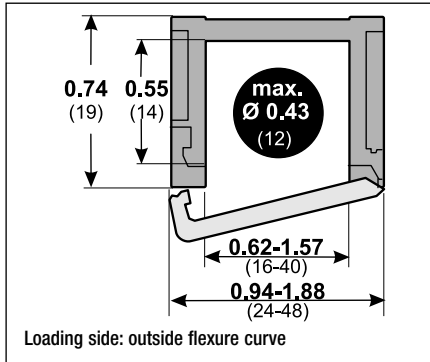

Material characteristics standard (PA/black)

Operating temperature: -22 to 248° F
 Gliding friction factor: 0.30
 Static friction factor: 0.45
 Fire classification: Based on UL94 HB

Other material properties on request

Technical specifications

Travel distance, gliding, L_g : 39.37 ft
 Travel distance, self-supporting, L_s : see diagram
 Travel distance, vertical, hanging, L_{vh} : 9.84 ft
 Travel distance, vertical, upright, L_{vu} : 6.56 ft
 Rotated 90°, self-supporting, L_{90r} : not recommended
 Speed, gliding, V_g : 6.56 ft/s
 Speed, self-supporting, V_s : 13.12 ft/s
 Acceleration, gliding, a_g : 6.56 ft/s²
 Acceleration, self-supporting, a_s : 6.56 ft/s²

Self-supporting length

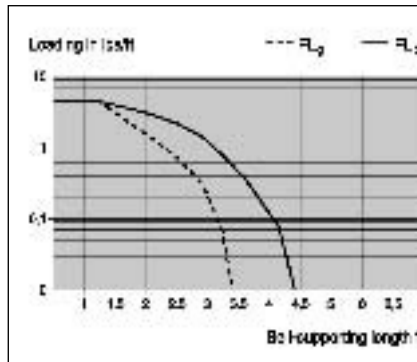
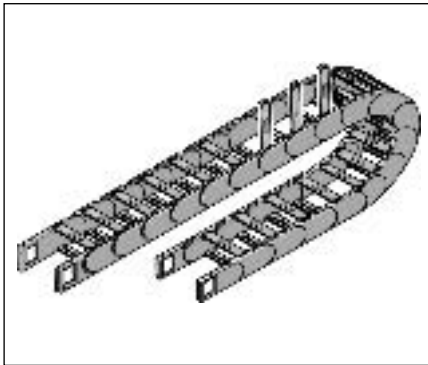

FL_g:
 Ideal installation situation for high stresses at the limit of the max. travel parameters. In this range the chain upper run is still biased, straight or has a max. sag of 0.39 – 1.97 in (10 – 50 mm) depending on the type of chain.

FL_s:
 Satisfactory installation position for many applications working in the lower to middle range of the max. travel parameters. Depending on the chain type, the sag of the chain upper run is >0.39 – 1.97 in (>10 – 50 mm) but certainly less than the max. sag.

If the sag is greater than FL_s, the arrangement is unsuitable and should be avoided. Please choose a more stable Murrplastik cable drag chain.

Determining the chain length

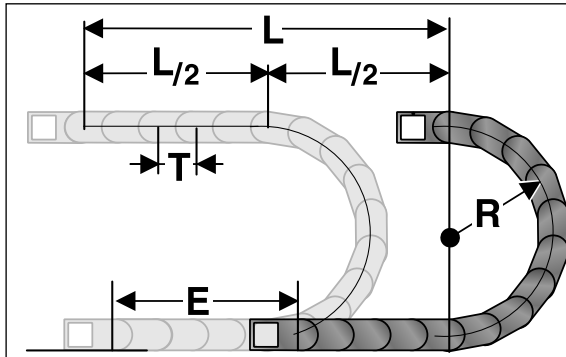

L = Travel distance
 R = Radius
 T = Pitch
 E = Distance between entry point and middle of travel distance

Determining the chain length

$$\text{Length} = \frac{L}{2} + \pi \times R + 2 \times T + E$$

≈ 1 ft(m) chain = 12(38) links each 1.02 in (26 mm)

The fixed point of the cable drag chain should be connected in the middle of the travel distance. This arrangement gives the shortest connection between the fixed point and the moving point and thus the most efficient chain length.

Installation dimensions (in inch)

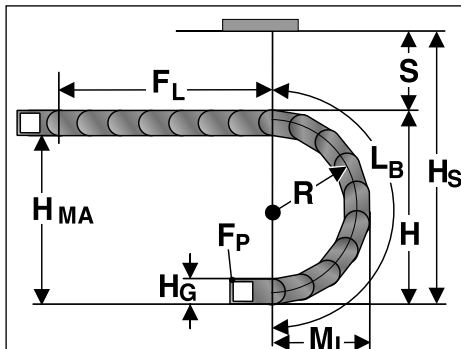

Radius R	0.98	1.50	1.89	2.95
Outside height of chain link (H _o)	0.75	0.75	0.75	0.75
Height of bend (H)	2.72	3.74	4.53	6.65
Height of moving end connection (H _{MA})	1.97	2.99	3.78	5.91
Safety margin (S)	0.79	0.79	0.79	0.79
Installation height (H _s)	3.50	4.53	5.31	7.44
Arc projection (M _L)	2.36	2.91	3.31	4.33
Bend length (L _b)	5.28	6.89	8.15	11.46



Chain bracket

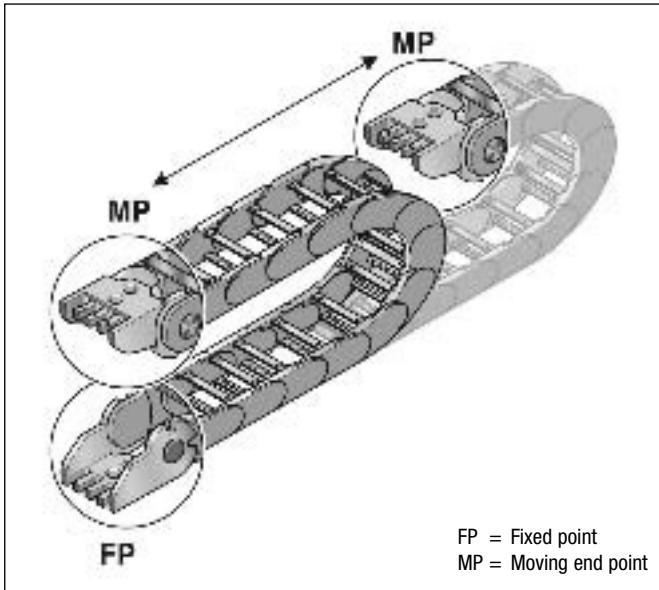

Chain bracket

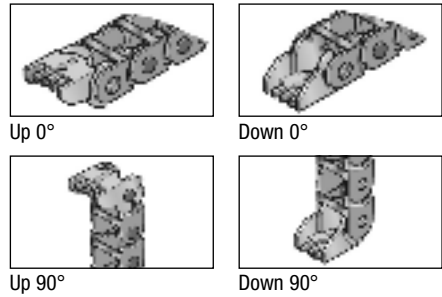

Chain bracket

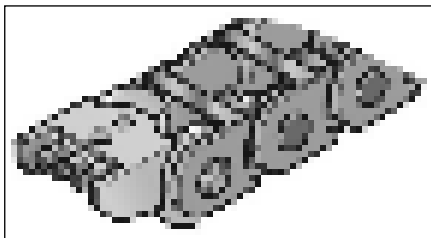

KA 14...

Type	Order no.	Pack qty.
KA 14016 Female end	014000005000	1
KA 14016 Male end	014000005100	1
KA 14020 Female end	014000005200	1
KA 14020 Male end	014000005300	1
KA 14030 Female end	014000005400	1
KA 14030 Male end	014000005500	1
KA 14040 Female end	014000005600	1
KA 14040 Male end	014000005700	1

The chain bracket is a fully plastic part. The bracket is precisely adjusted to the respective chain width and only needs to be snapped in at the chain link. Please order one male and one female end bracket for each chain. The brackets should be fastened with M3 screws. The cables or conduits may be fastened with cable ties on the integrated strain relief of the chain bracket.

Chain bracket

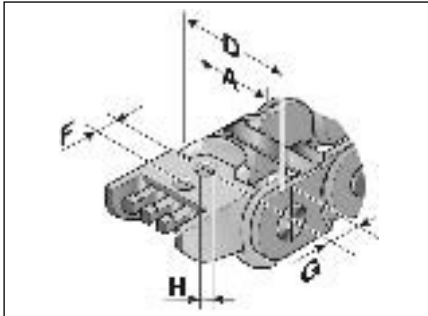

KA 14016-020

Type	A inch	D inch	F inch	G inch	H Ø inch
KA 14016 Female end	0.63	0.94	0.31	0.43	0.13
KA 14016 Male end	0.63	0.94	0.31	0.30	0.13
KA 14020 Female end	0.79	1.10	0.31	0.43	0.13
KA 14020 Male end	0.79	1.10	0.31	0.30	0.13

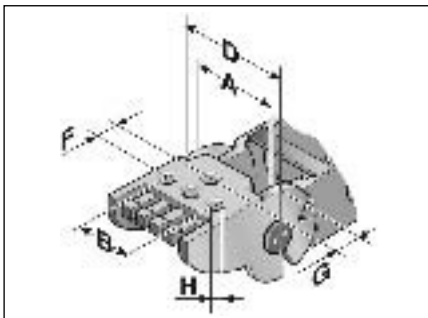

KA 14030-040

Type	A inch	B inch	D inch	F inch	G inch	H Ø inch
KA 14030 Female end	1.18	0.87	1.50	0.31	0.43	0.13
KA 14030 Male end	1.18	0.87	1.50	0.31	0.30	0.13
KA 14040 Female end	1.57	1.26	1.89	0.31	0.43	0.13
KA 14040 Male end	1.57	1.26	1.89	0.31	0.30	0.13

Separator

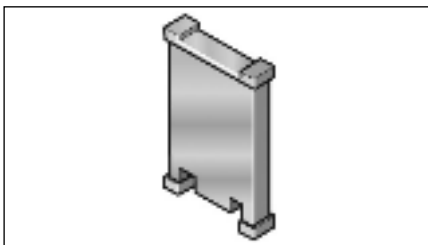

Separator

Type	Order no.	Designation	Pack qty.
TR 14	014000009200	Separator	1

We recommend that separators be used if multiple round cables or conduits with differing diameters are to be installed. An offset configuration of the separators is advisable.

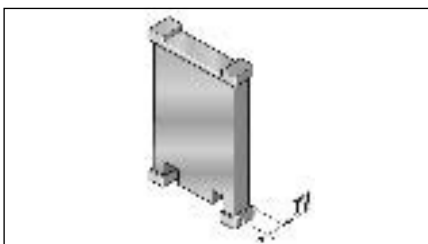

Separator

Type	TI inch
TR 14	0.06



MP 14 - Accessories

Assembly Disassembly

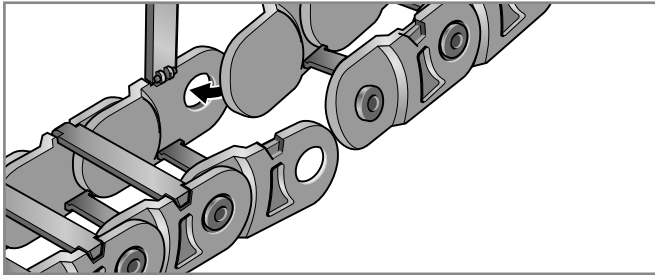

Step 1

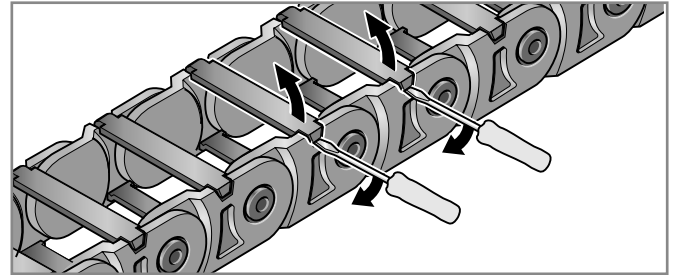

Step 1

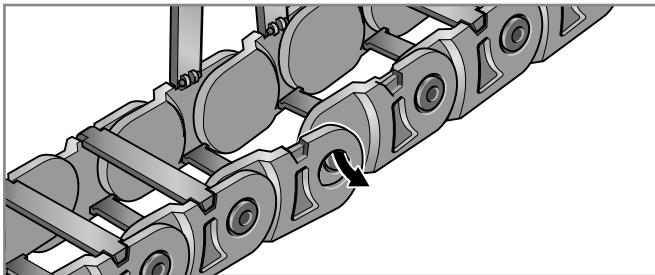

Step 2

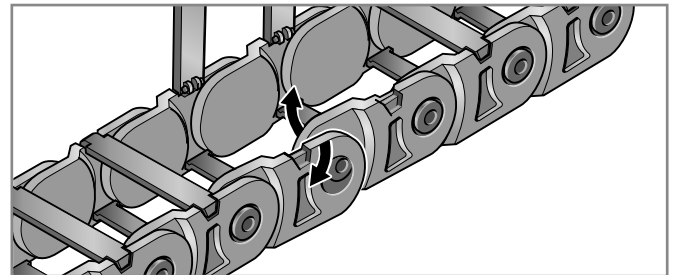

Step 2

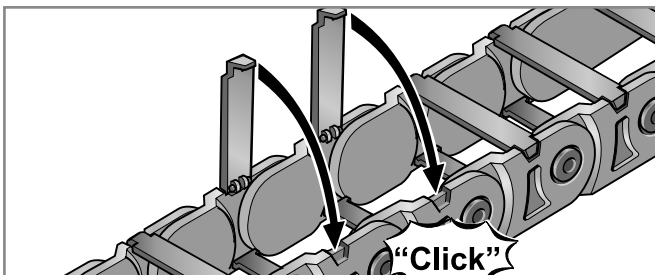

Step 3

Cable drag chain systems

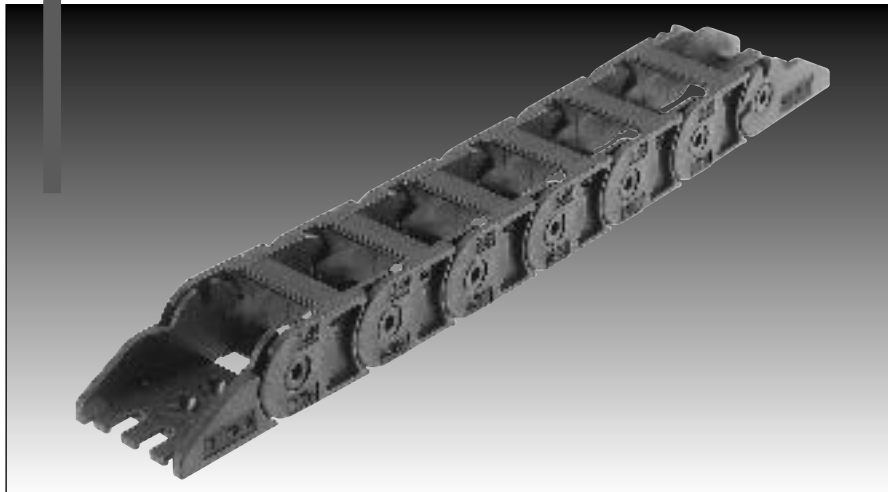

MultiLine

MP 15



MP 15 - MultiLine

Order variants

Style (order code)						
Configuration (order code)						
Radius (order code) <small>The radii can be combined with any internal width</small>						
in inch						
Internal width (order code)						
in inch						
Outside width (order code)						
in inch						
MP15 016	0.94	0.63	016	0.98	025	0
MP15 020	1.10	0.79	020	1.50	038	1
MP15 030	1.50	1.18	030	1.89	048	7
MP15 040	1.89	1.57	040	2.95	075	9
					0	9

Order-Number:	0150			0			0
----------------------	-------------	--	--	----------	--	--	----------

Configuration:

0 PA crossbar every link; w/bias

Style:

0 Standard (PA/black)
 1 UL94/V0 (PA/oxide red)
 7 ESD (PA/light gray)
 9 Custom version

Sample order:

0150 016 025 0000

Internal width = 0.63 (16 mm)
 Radius = 0.98 in (25 mm)
 Configuration = 0
 Style = 0

Ideal operating conditions:





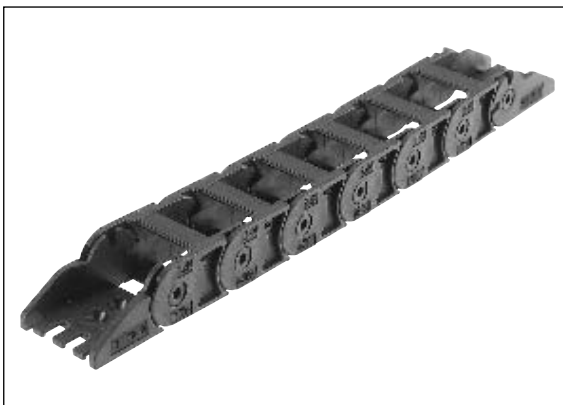

- Closed structure gives high degree of stiffness and torsional strength
- Quiet operation
- Compact dimensions with high stability
- Unsupported arrangement
- Gliding arrangement

Alternative chain type:

- MP 14 Cover variant for opening
- MP 18.1/MP 18.2 Great self-supporting lengths

Features



-  Radii with medium bias (R) for all applications
-  ESD cable drag chains for use in areas at risk of explosion
-  Integrable separator for cable separation
-  Chain bracket with integrated strain relief
-  ESD cable drag chains for use in areas of electrostatic discharge
-  UL version in oxide red, classification V0

Technical data

Chain link dimensions (inch) (mm)

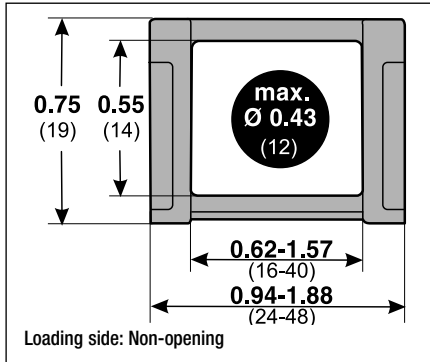

Material characteristics standard (PA/black)

Operating temperature: -22 to 248° F
 Gliding friction factor: 0.30
 Static friction factor: 0.45
 Fire classification: Based on UL94 HB

Other material properties on request

Technical specifications

Travel distance, gliding, L_g : 39.37 ft
 Travel distance, self-supporting, L_s : see diagram
 Travel distance, vertical, hanging, L_{vh} : 9.84 ft
 Travel distance, vertical, upright, L_{vu} : 6.56 ft
 Rotated 90°, self-supporting, L_{90r} : not recommended
 Speed, gliding, V_g : 6.56 ft/s
 Speed, self-supporting, V_s : 13.12 ft/s
 Acceleration, gliding, a_g : 6.56 ft/s²
 Acceleration, self-supporting, a_s : 6.56 ft/s²

Self-supporting length

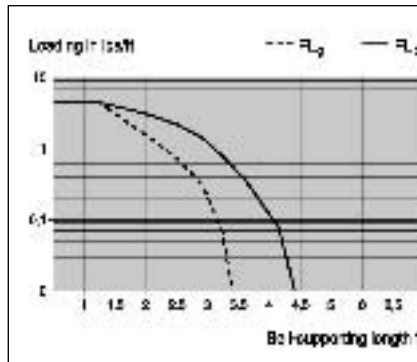
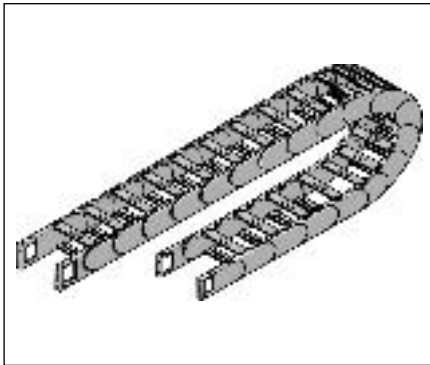

FL_g :
 Ideal installation situation for high stresses at the limit of the max. travel parameters. In this range the chain upper run is still biased, straight or has a max. sag of 0.39 – 1.97 in (10 – 50 mm) depending on the type of chain.

FL_s :
 Satisfactory installation position for many applications working in the lower to middle range of the max. travel parameters. Depending on the chain type, the sag of the chain upper run is >0.39 – 1.97 in (>10 – 50 mm) but certainly less than the max. sag.

If the sag is greater than FL_s , the arrangement is unsuitable and should be avoided. Please choose a more stable Murrplastik cable drag chain.

Determining the chain length

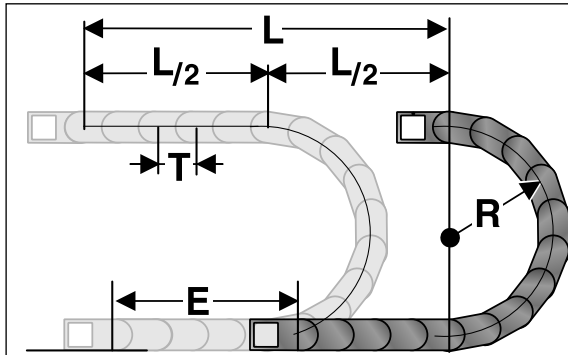

Determining the chain length

$$\text{Length} = \frac{L}{2} + \pi \times R + 2 \times T + E$$

≈ 1 ft(m) chain = 12(38) links each 1.02 in (26 mm)

The fixed point of the cable drag chain should be connected in the middle of the travel distance. This arrangement gives the shortest connection between the fixed point and the moving point and thus the most efficient chain length.

Installation dimensions (in inch)

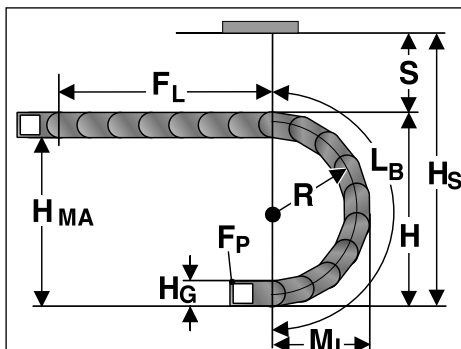

Radius R	0.98	1.50	1.89	2.95
Outside height of chain link (H_c)	0.75	0.75	0.75	0.75
Height of bend (H)	2.72	3.74	4.53	6.65
Height of moving end connection (H_{MA})	1.97	2.99	3.78	5.91
Safety margin (S)	0.79	0.79	0.79	0.79
Installation height (H_s)	3.50	4.53	5.31	7.44
Arc projection (M_L)	2.36	2.91	3.31	4.33
Bend length (L_b)	5.28	6.89	8.15	11.46



Chain bracket

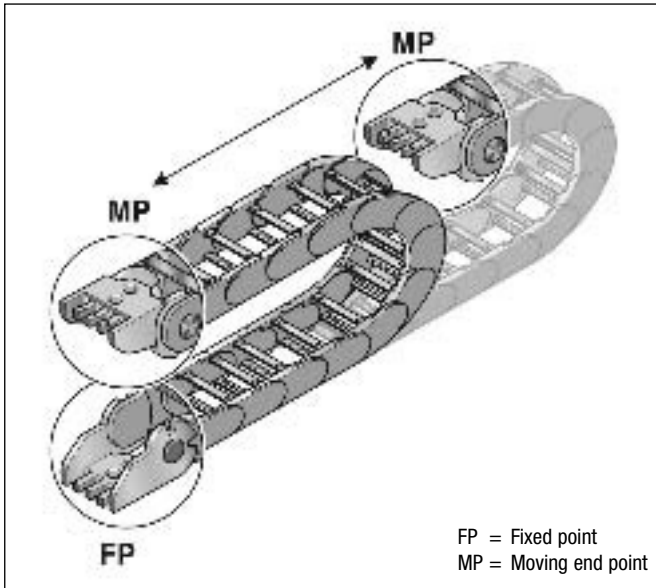

Chain bracket

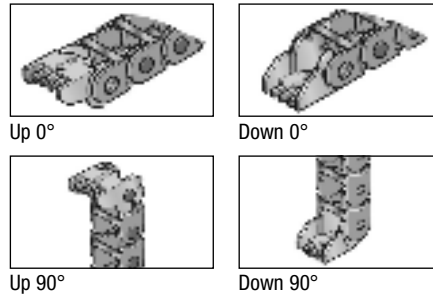

Chain bracket

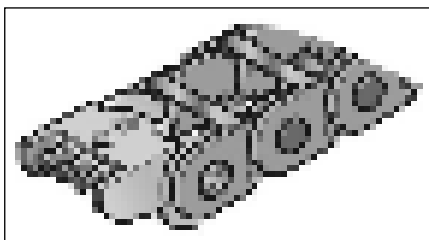

KA 14...

Type	Order no.	Pack qty.
KA 14016 Female end	014000005000	1
KA 14016 Male end	014000005100	1
KA 14020 Female end	014000005200	1
KA 14020 Male end	014000005300	1
KA 14030 Female end	014000005400	1
KA 14030 Male end	014000005500	1
KA 14040 Female end	014000005600	1
KA 14040 Male end	014000005700	1

The chain bracket is a fully plastic part. The bracket is precisely adjusted to the respective chain width and only needs to be snapped in at the chain link. Please order one male and one female end bracket for each chain. The brackets should be fastened with M3 screws. The cables or conduits may be fastened with cable ties on the integrated strain relief of the chain bracket.

Chain bracket

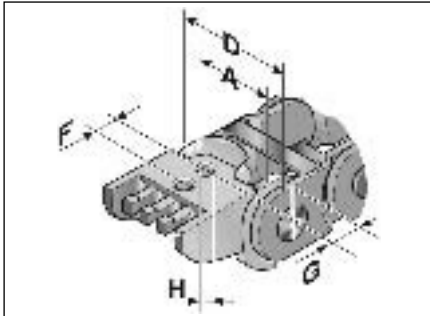

KA 14016-020

Type	A inch	D inch	F inch	G inch	H Ø inch
KA 14016 Female end	0.63	0.94	0.31	0.43	0.13
KA 14016 Male end	0.63	0.94	0.31	0.30	0.13
KA 14020 Female end	0.79	1.10	0.31	0.43	0.13
KA 14020 Male end	0.79	1.10	0.31	0.30	0.13

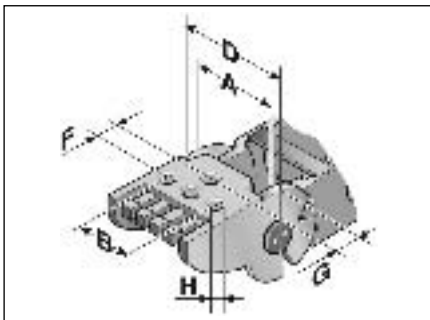

KA 14030-040

Type	A inch	B inch	D inch	F inch	G inch	H Ø inch
KA 14030 Female end	1.18	0.87	1.50	0.31	0.43	0.13
KA 14030 Male end	1.18	0.87	1.50	0.31	0.30	0.13
KA 14040 Female end	1.57	1.26	1.89	0.31	0.43	0.13
KA 14040 Male end	1.57	1.26	1.89	0.31	0.30	0.13

Assembly

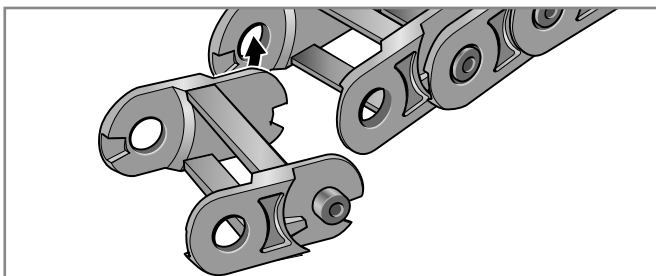

Step 1

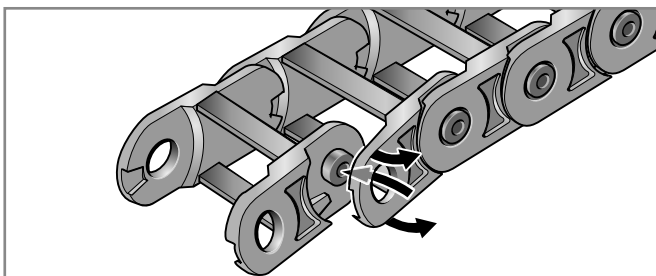

Step 2

Disassembly

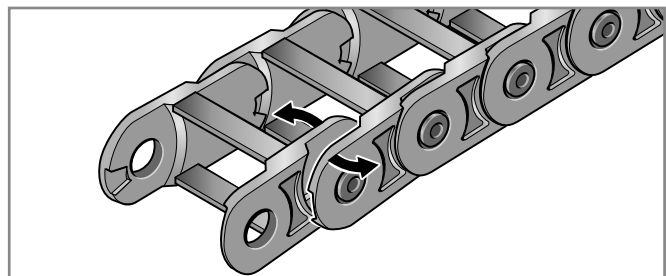

Step 1

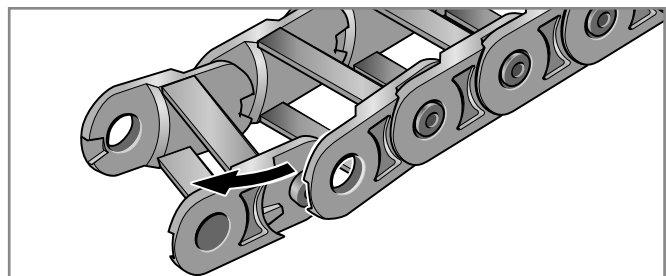

Step 2

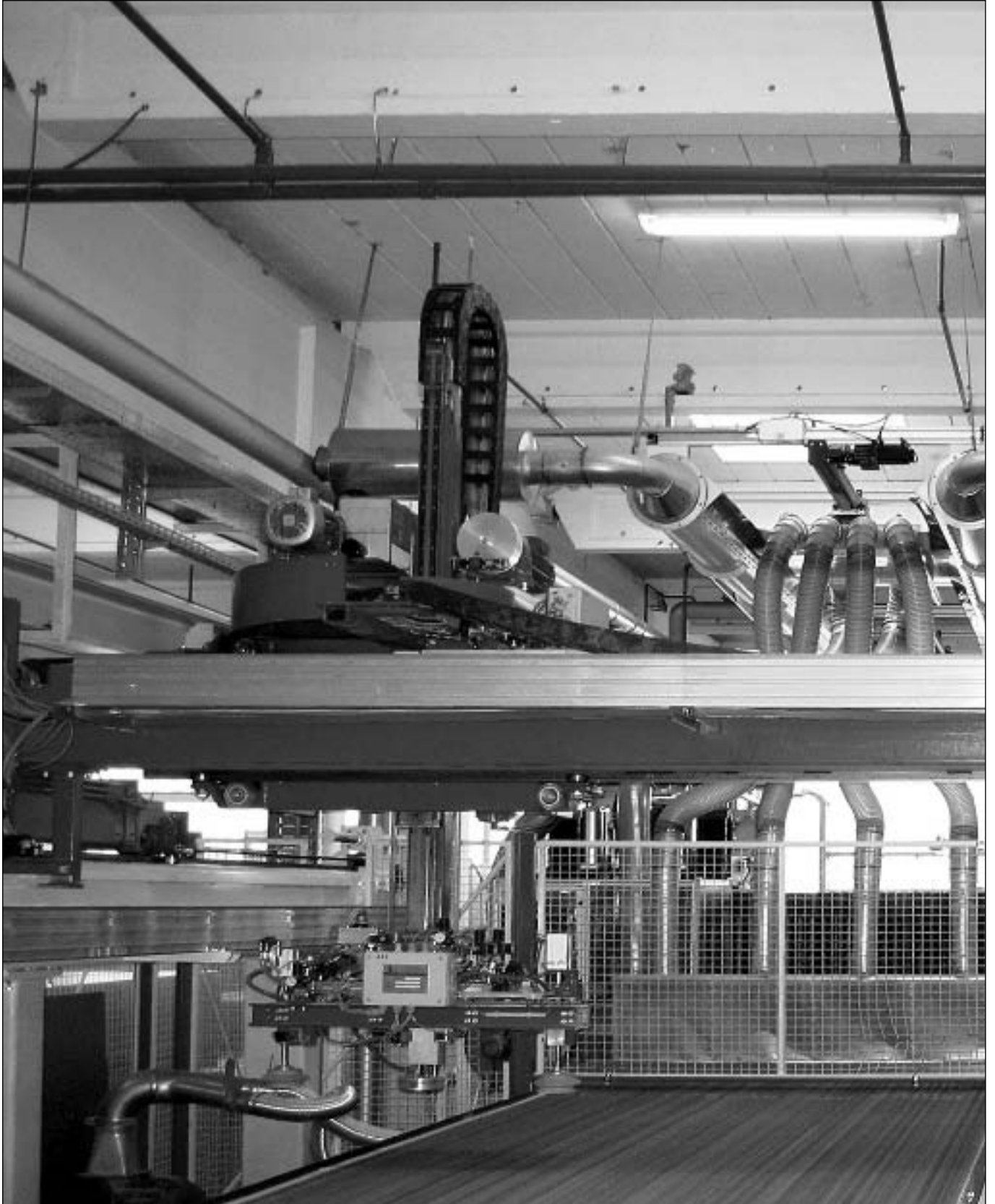

Cable drag chain systems

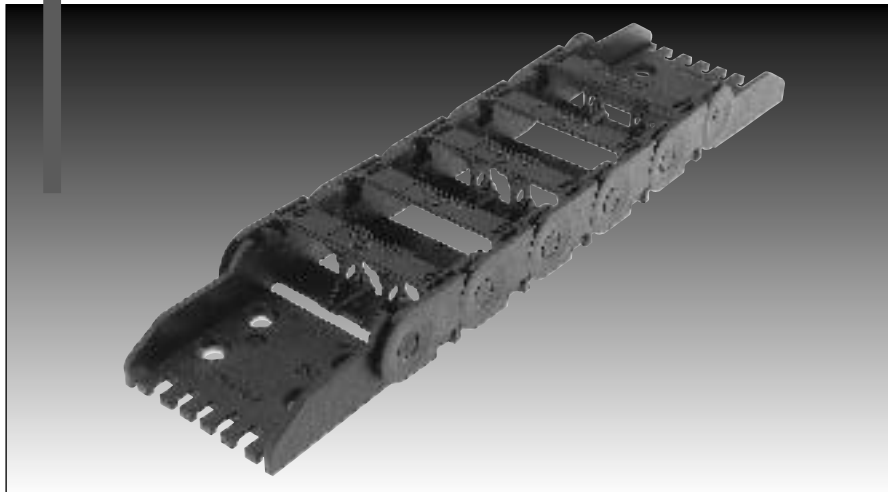

MultiLine

MP 18.1



MP 18.1 - MultiLine

Order variants

Style (order code)						
Configuration (order code)						
Radius (order code) <small>The radii can be combined with any internal width</small>						
in inch						
Internal width (order code)						
in inch						
Outside width (order code)						
in inch						
MP18.1 015	1.10	0.59	015			
MP18.1 018	1.22	0.71	018			0
MP18.1 025	1.50	0.98	025	1.10	028	1
MP18.1 037	1.97	1.46	037	1.50	038	5
MP18.1 050	2.48	1.97	050	1.89	048	7
MP18.1 070	3.27	2.76	070	3.07	078	9
						0

Order-Number:	0181		0		0
----------------------	-------------	--	----------	--	----------

Configuration:

0 PA crossbar every link; w/bias

Style:

0 Standard (PA/black)
 1 UL94/V0 (PA/oxide red)
 5 Polypropylene (PP/blue)
 7 ESD (PA/light gray)
 9 Custom version

Sample order:

0181 015 028 0000

Internal width = 0.59 in (15 mm)
 Radius = 1.10 in (28 mm)
 Configuration = 0
 Style = 0

Ideal operating conditions:







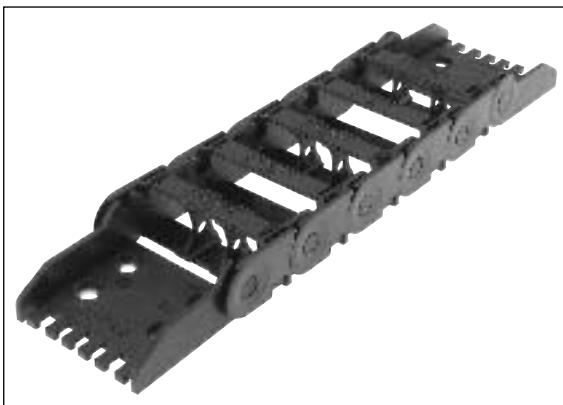

- Compact dimensions with opening cover in outside bend
- Quiet operation
- High stability
- Flexible internal separation
- Gliding arrangement
- Unsupported arrangement
- Rotated 90° unsupported

Alternative chain type:

- MP 18. opening cover in inside bend
- MP 3000 greater unsupported lengths

Features



-  Radii with medium bias (R) for all applications
-  Reverse radius combinations
-  ESD cable drag chains for use in areas of electrostatic discharge
-  Crossbars, folding on one side
-  ESD cable drag chains for use in areas at risk of explosion
-  Integrable separator for cable separation
-  Chain bracket with metal inserts and strain relief
-  UL version in oxide red, classification V0

Technical data

Chain link dimensions (inch) (mm)

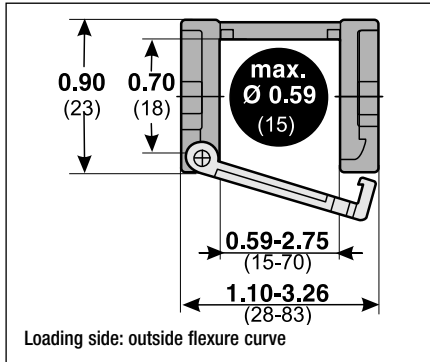

Material characteristics standard (PA/black)

Operating temperature: -22 to 248° F
Gliding friction factor: 0.30
Static friction factor: 0.45
Fire classification: Based on UL94 HB

Other material properties on request

Technical specifications

Travel distance, gliding, L_g : 65.62 ft
Travel distance, self-supporting, L_s : see diagram
Travel distance, vertical, hanging, L_{vh} : 26.25 ft
Travel distance, vertical, upright, L_{vu} : 9.84 ft
Rotated 90°, self-supporting, L_{90r} : 1.64 ft
Speed, gliding, V_g : 6.56 ft/s
Speed, self-supporting, V_s : 16.40 ft/s
Acceleration, gliding, a_g : 16.40 ft/s²
Acceleration, self-supporting, a_s : 16.40 ft/s²

Self-supporting length

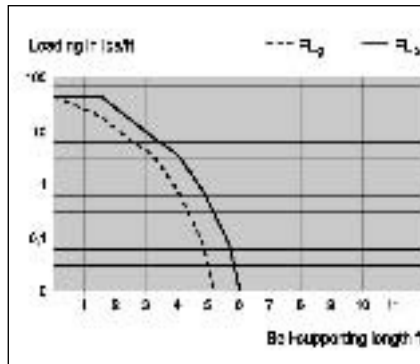
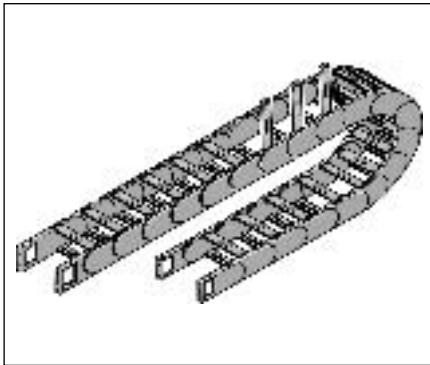

FL_g :

Ideal installation situation for high stresses at the limit of the max. travel parameters. In this range the chain upper run is still biased, straight or has a max. sag of 0.39 – 1.97 in (10 – 50 mm) depending on the type of chain.

FL_s :

Satisfactory installation position for many applications working in the lower to middle range of the max. travel parameters. Depending on the chain type, the sag of the chain upper run is >0.39 – 1.97 in (>10 – 50 mm) but certainly less than the max. sag.

If the sag is greater than FL_s , the arrangement is unsuitable and should be avoided. Please choose a more stable Murrplastik cable drag chain.

Determining the chain length

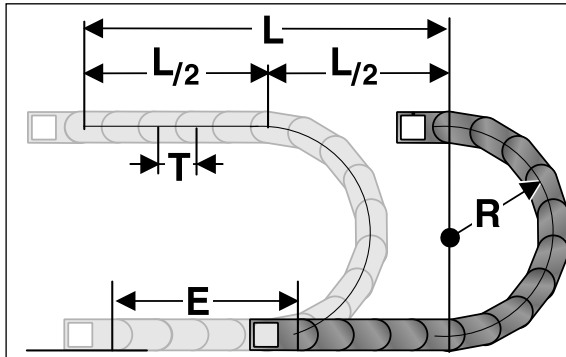

Determining the chain length

$$\text{Length} = \frac{L}{2} + \pi \times R + 2 \times T + E$$

$$\approx 1 \text{ ft(m) chain} = 10(30) \text{ links each } 1.30 \text{ in (33 mm)}$$

The fixed point of the cable drag chain should be connected in the middle of the travel distance. This arrangement gives the shortest connection between the fixed point and the moving point and thus the most efficient chain length.

Installation dimensions (in inch)

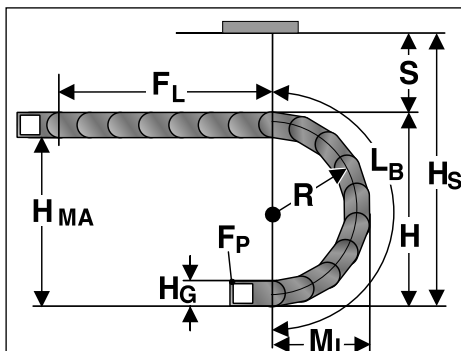

Radius R	1.10	1.50	1.89	3.07
Outside height of chain link (H_o)	0.91	0.91	0.91	0.91
Height of bend (H)	3.11	3.90	4.69	7.05
Height of moving end connection (H_{MA})	2.20	2.99	3.78	6.14
Safety margin (S)	1.18	1.18	1.18	1.18
Installation height (H_s)	4.29	5.08	5.78	8.23
Arc projection (M_L)	2.83	3.23	3.62	4.80
Bend length (L_b)	6.18	7.40	8.66	12.36



Chain bracket

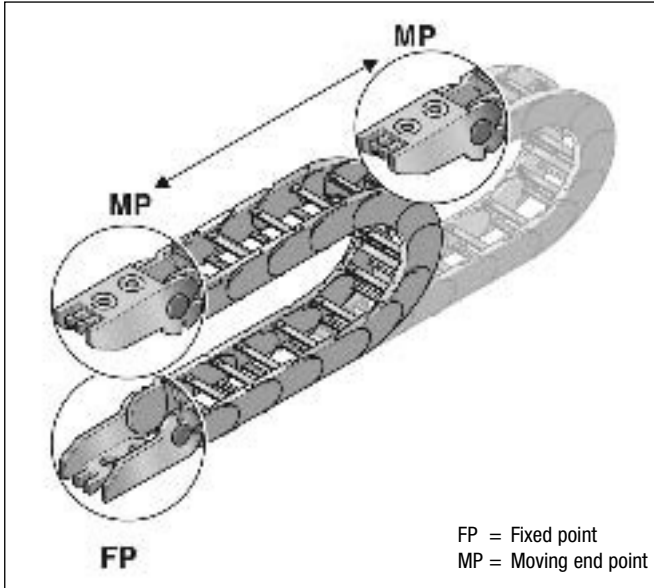

Chain bracket

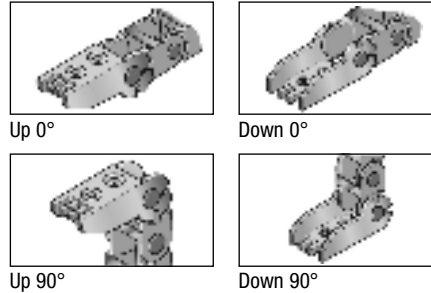

Chain bracket

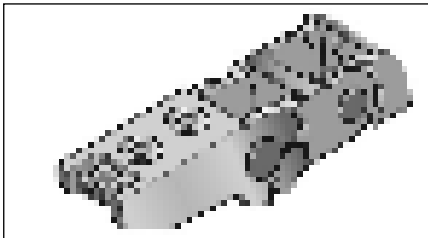

KA/Z 18...

Type	Order no.	Pack qty.
KA/Z 18015 female end	018100004800	1
KA/Z 18015 male end	018100004900	1
KA/Z 18018 female end	018100005000	1
KA/Z 18018 male end	018100005100	1
KA/Z 18025 female end	018100005200	1
KA/Z 18025 male end	018100005300	1
KA/Z 18037 female end	018100005400	1
KA/Z 18037 male end	018100005500	1
KA/Z 18050 female end	018100005600	1
KA/Z 18050 male end	018100005700	1
KA/Z 18070 female end	018100005800	1
KA/Z 18070 male end	018100005900	1

The chain bracket is an all plastics part with extrusion coated metal insert. The bracket is precisely adjusted to the respective chain width and only needs to be snapped in at the chain link. Please order one male and one female end bracket for each chain. The brackets should be fastened with M5 screws. The cables or conduits may be fastened with cable ties on the integrated strain relief of the chain bracket.

Chain bracket

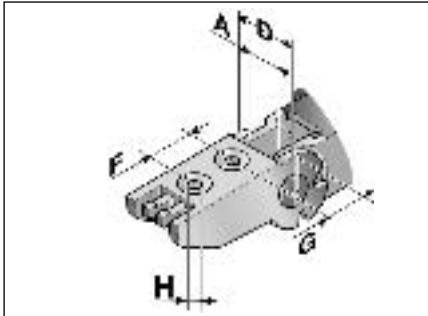

KA/Z 18015-025

Type	A inch	D inch	F inch	G inch	H Ø inch
KA/Z 18015 female end	0.61	1.06	0.75	0.41	0.22
KA/Z 18015 male end	0.61	1.06	0.75	0.33	0.22
KA/Z 18018 female end	0.72	1.18	0.75	0.41	0.22
KA/Z 18018 male end	0.72	1.18	0.75	0.33	0.22
KA/Z 18025 female end	1.00	1.46	0.75	0.41	0.22
KA/Z 18025 male end	1.00	1.46	0.75	0.33	0.22

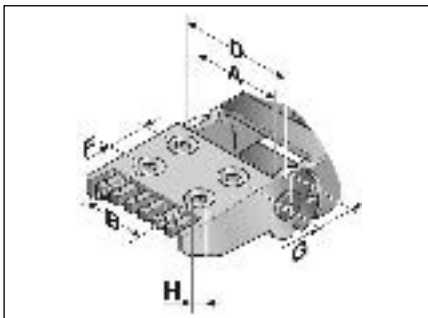

KA/Z 18037-070

Type	A inch	B inch	D inch	F inch	G inch	H Ø inch
KA/Z 18037 female end	1.47	0.79	1.93	0.75	0.41	0.22
KA/Z 18037 male end	1.47	0.79	1.93	0.75	0.33	0.22
KA/Z 18050 female end	1.98	1.34	2.44	0.75	0.41	0.22
KA/Z 18050 male end	1.98	1.34	2.44	0.75	0.33	0.22
KA/Z 18070 female end	2.77	1.89	3.23	0.75	0.41	0.22
KA/Z 18070 male end	2.77	1.89	3.23	0.75	0.33	0.22

Separator



Separator

Type	Order no.	Designation	Pack qty.
TR 14 18	018200009000	Separator	1

We recommend that separators be used if multiple round cables or conduits with differing diameters are to be installed. An offset configuration of the separators is advisable.



Separator

Type	T1 inch
TR 14 18	0.06



MP 18.1 - Accessories

Assembly Disassembly

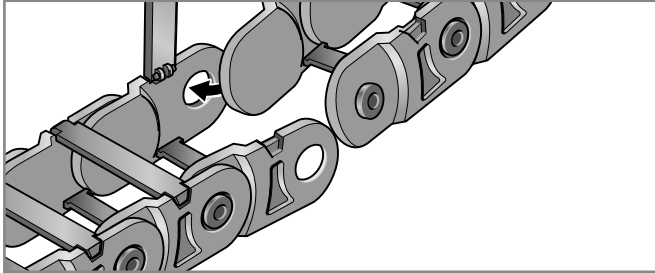

Step 1

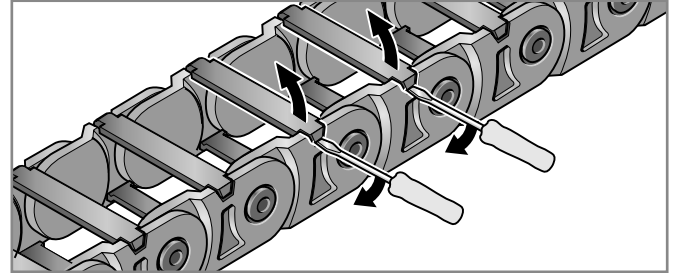

Step 1

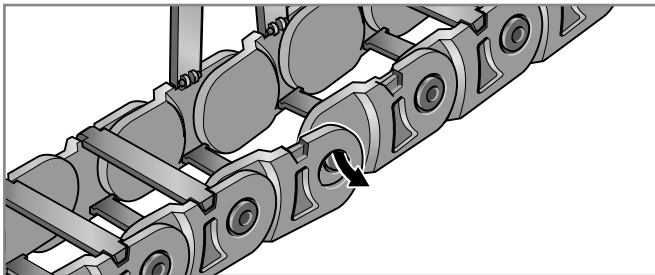

Step 2

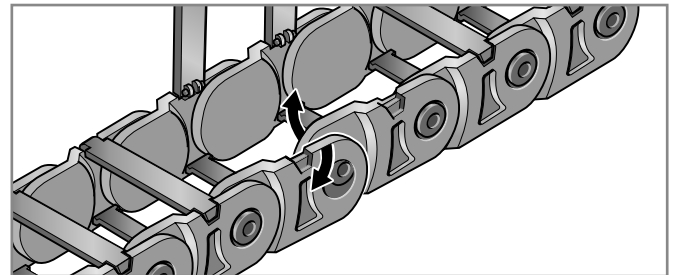

Step 2

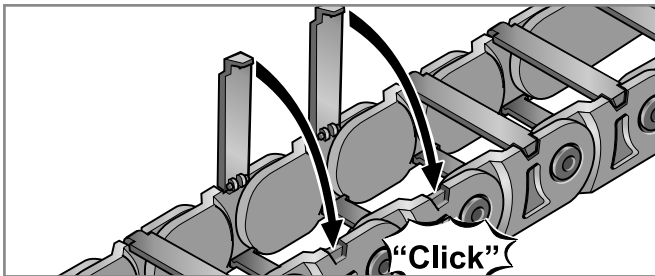

Step 3

Cable drag chain systems

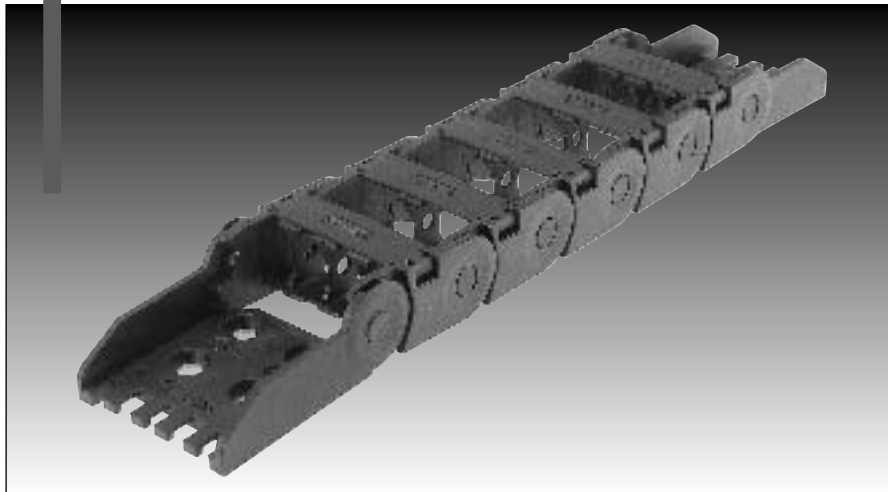

MultiLine

MP 18.2



MP 18.2 - MultiLine

Order variants

Style (order code)						
Configuration (order code)						
Radius (order code) <small>The radii can be combined with any internal width</small>						
in inch						
Internal width (order code)						
in inch						
Outside width (order code)						
in inch						
MP18.2 015	1.10	0.59	015			
MP18.2 018	1.22	0.71	018			
MP18.2 025	1.50	0.98	025	1.10	028	
MP18.2 037	1.97	1.46	037	1.50	038	
MP18.2 050	2.48	1.97	050	1.89	048	
MP18.2 070	3.27	2.76	070	3.07	078	
						0
						1
						5
						7
						9

Order-Number:

Configuration:

0 PA crossbar every link; w/bias

Style:

0 Standard (PA/black)
 1 UL94/V0 (PA/oxide red)
 5 Polypropylene (PP/blue)
 7 ESD (PA/light gray)
 9 Custom version

Sample order:

0182 015 028 0000

Internal width = 0.59 in (15 mm)
 Radius = 1.10 in (28 mm)
 Configuration = 0
 Style = 0

Ideal operating conditions:







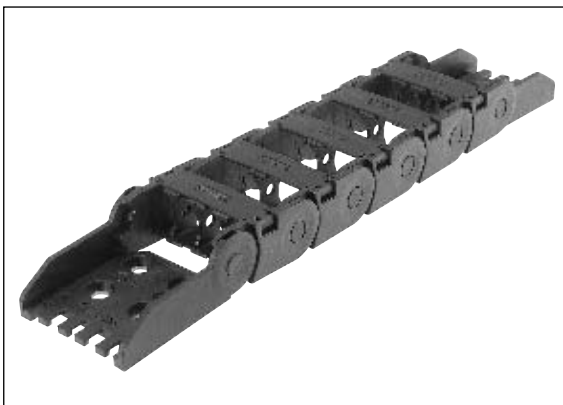

- Compact dimensions with opening cover in inside bend
- Quiet operation
- High stability
- Flexible internal separation
- Unsupported arrangement
- Rotated 90° unsupported

Alternative chain type:

- MP 18.1 Opening cover on outside of radius
- MP 3000 greater unsupported lengths
- MP 18.1 gliding arrangement

Features



-  Radii with medium bias (R) for all applications
-  Reverse radius combinations
-  ESD cable drag chains for use in areas of electrostatic discharge
-  Crossbars, folding on one side
-  ESD cable drag chains for use in areas at risk of explosion
-  Integrable separator for cable separation
-  Chain bracket with metal inserts and strain relief
-  UL version in oxide red, classification V0

Technical data

Chain link dimensions (inch) (mm)

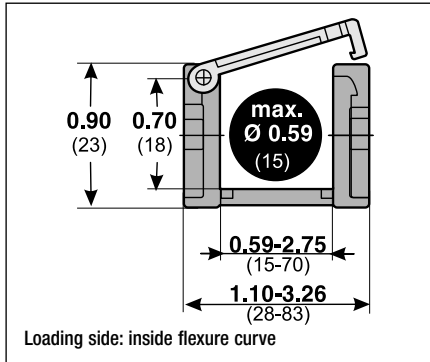

Material characteristics standard (PA/black)

Operating temperature: -22 to 248° F
 Gliding friction factor: 0.30
 Static friction factor: 0.45
 Fire classification: Based on UL94 HB

Other material properties on request

Technical specifications

Travel distance, gliding, L_g : not recommended
 Travel distance, self-supporting, L_s : see diagram
 Travel distance, vertical, hanging, L_{vh} : 26.25 ft
 Travel distance, vertical, upright, L_{vs} : 9.84 ft
 Rotated 90°, self-supporting, L_{90r} : 1.64 ft
 Speed, self-supporting, V_s : 16.40 ft/s
 Acceleration, self-supporting, a_s : 16.40 ft/s²

Self-supporting length

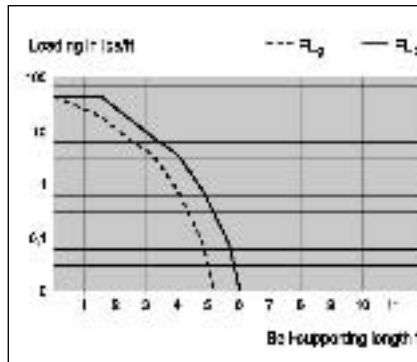
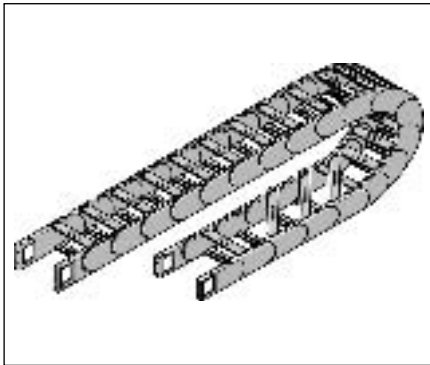

FL_g:
 Ideal installation situation for high stresses at the limit of the max. travel parameters. In this range the chain upper run is still biased, straight or has a max. sag of 0.39 – 1.97 in (10 – 50 mm) depending on the type of chain.

FL_s:
 Satisfactory installation position for many applications working in the lower to middle range of the max. travel parameters. Depending on the chain type, the sag of the chain upper run is >0.39 – 1.97 in (>10 – 50 mm) but certainly less than the max. sag.

If the sag is greater than FL_s, the arrangement is unsuitable and should be avoided. Please choose a more stable Murrplastik cable drag chain.

Determining the chain length

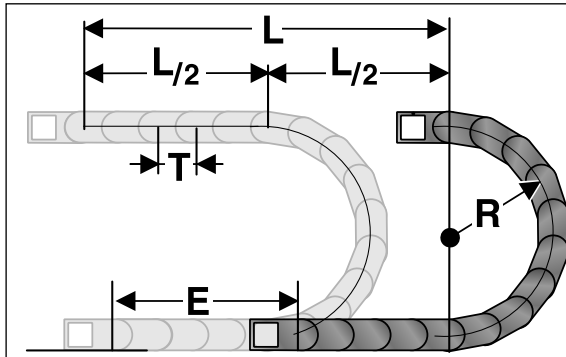

L = Travel distance
 R = Radius
 T = Pitch
 E = Distance between entry point and middle of travel distance

Determining the chain length

$$\text{Length} = \frac{L}{2} + \pi \times R + 2 \times T + E$$

≈ 1 ft(m) chain = 10(30) links each 1.30 in (33 mm)

The fixed point of the cable drag chain should be connected in the middle of the travel distance. This arrangement gives the shortest connection between the fixed point and the moving point and thus the most efficient chain length.

Installation dimensions (in inch)

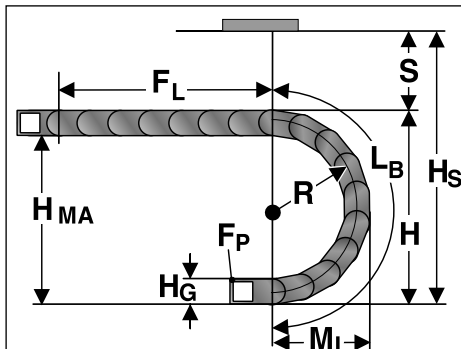

Radius R	1.10	1.50	1.89	3.07
Outside height of chain link (H_o)	0.91	0.91	0.91	0.91
Height of bend (H)	3.11	3.90	4.69	7.05
Height of moving end connection (H_{MA})	2.20	2.99	3.78	6.14
Safety margin (S)	1.18	1.18	1.18	1.18
Installation height (H_s)	4.29	5.08	5.87	8.23
Arc projection (M_L)	2.83	3.23	3.62	4.80
Bend length (L_b)	6.18	7.40	8.66	12.36



Chain bracket

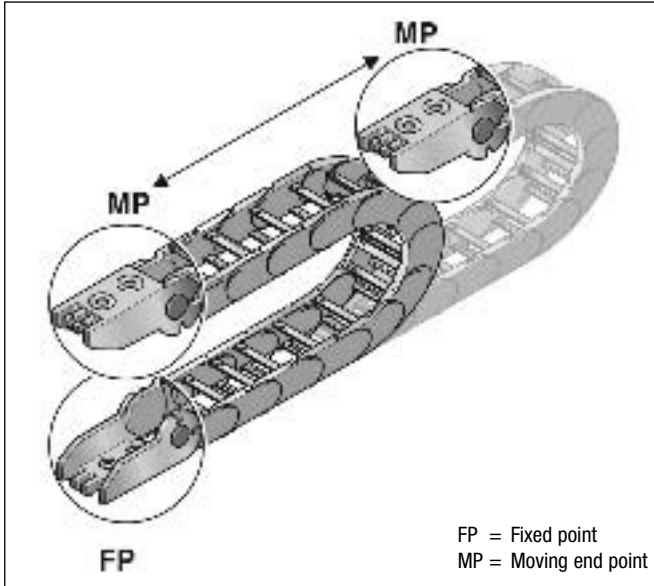

Chain bracket

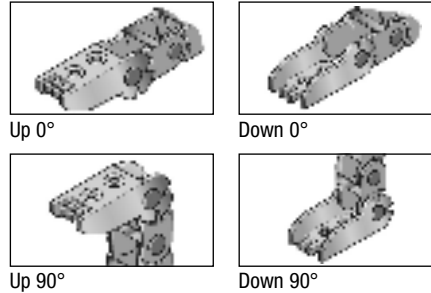

Chain bracket

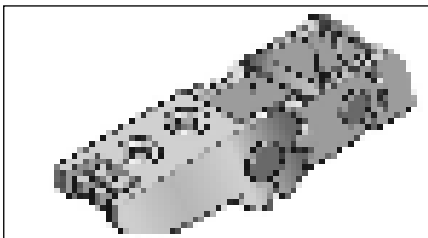

KA/Z 18...

Type	Order no.	Pack qty.
KA/Z 18015 female end	018100004800	1
KA/Z 18015 male end	018100004900	1
KA/Z 18018 female end	018100005000	1
KA/Z 18018 male end	018100005100	1
KA/Z 18025 female end	018100005200	1
KA/Z 18025 male end	018100005300	1
KA/Z 18037 female end	018100005400	1
KA/Z 18037 male end	018100005500	1
KA/Z 18050 female end	018100005600	1
KA/Z 18050 male end	018100005700	1
KA/Z 18070 female end	018100005800	1
KA/Z 18070 male end	018100005900	1

The chain bracket is an all plastics part with extrusion coated metal insert. The bracket is precisely adjusted to the respective chain width and only needs to be snapped in at the chain link. Please order one male and one female end bracket for each chain. The brackets should be fastened with M5 screws. The cables or conduits may be fastened with cable ties on the integrated strain relief of the chain bracket.

Chain bracket

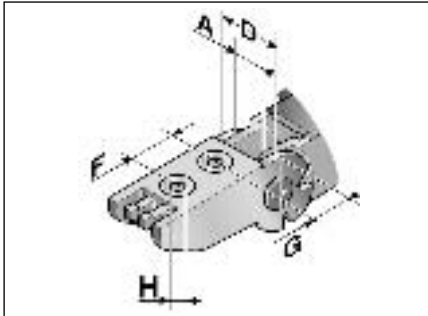

KA/Z 18015-025

Type	A inch	D inch	F inch	G inch	H Ø inch
KA/Z 18015 female end	0.61	1.06	0.75	0.41	0.22
KA/Z 18015 male end	0.61	1.06	0.75	0.33	0.22
KA/Z 18018 female end	0.72	1.18	0.75	0.41	0.22
KA/Z 18018 male end	0.72	1.18	0.75	0.33	0.22
KA/Z 18025 female end	1.00	1.46	0.75	0.41	0.22
KA/Z 18025 male end	1.00	1.46	0.75	0.33	0.22

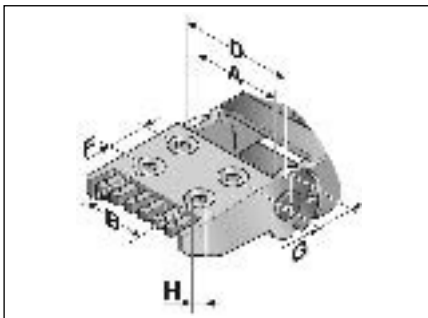

KA/Z 18037-070

Type	A inch	B inch	D inch	F inch	G inch	H Ø inch
KA/Z 18037 female end	1.47	0.79	1.93	0.75	0.41	0.22
KA/Z 18037 male end	1.47	0.79	1.93	0.75	0.33	0.22
KA/Z 18050 female end	1.98	1.34	2.44	0.75	0.41	0.22
KA/Z 18050 male end	1.98	1.34	2.44	0.75	0.33	0.22
KA/Z 18070 female end	2.77	1.89	3.23	0.75	0.41	0.22
KA/Z 18070 male end	2.77	1.89	3.23	0.75	0.33	0.22

Separator



Separator

Type	Order no.	Designation	Pack qty.
TR 14 18	018200009000	Separator	1

We recommend that separators be used if multiple round cables or conduits with differing diameters are to be installed. An offset configuration of the separators is advisable.



Separator

Type	TI inch
TR 14/18	0.06



MP 18.2 - Accessories

Assembly

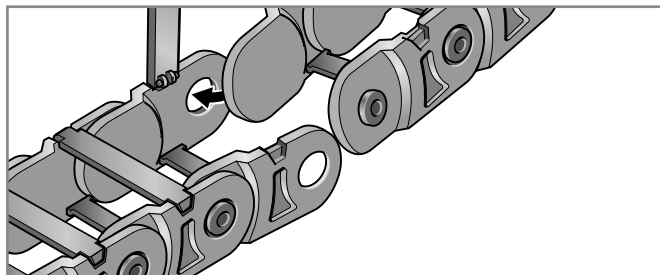

Step 1

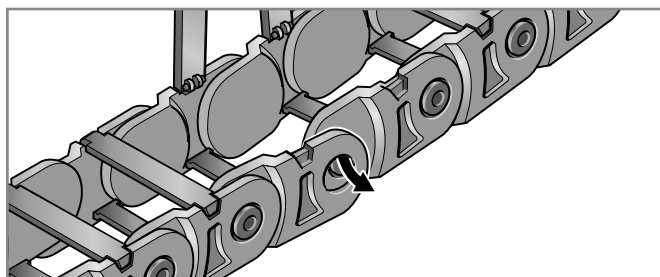

Step 2

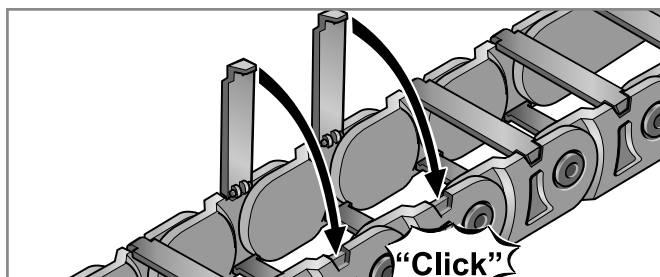

Step 3

Disassembly

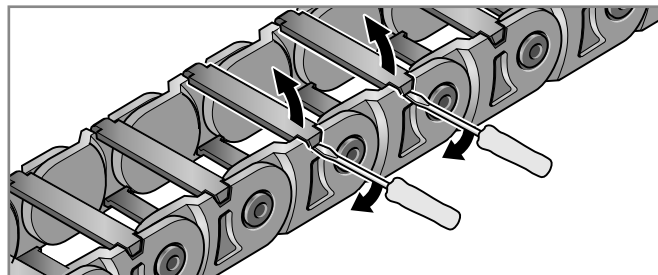

Step 1

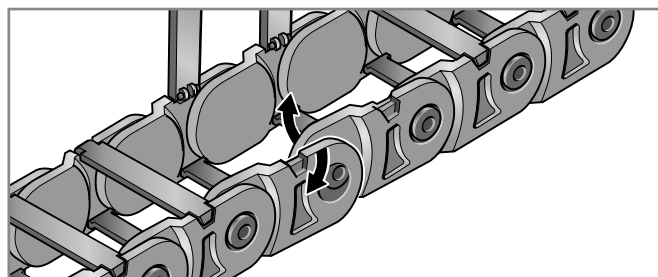

Step 2

Cable drag chain systems

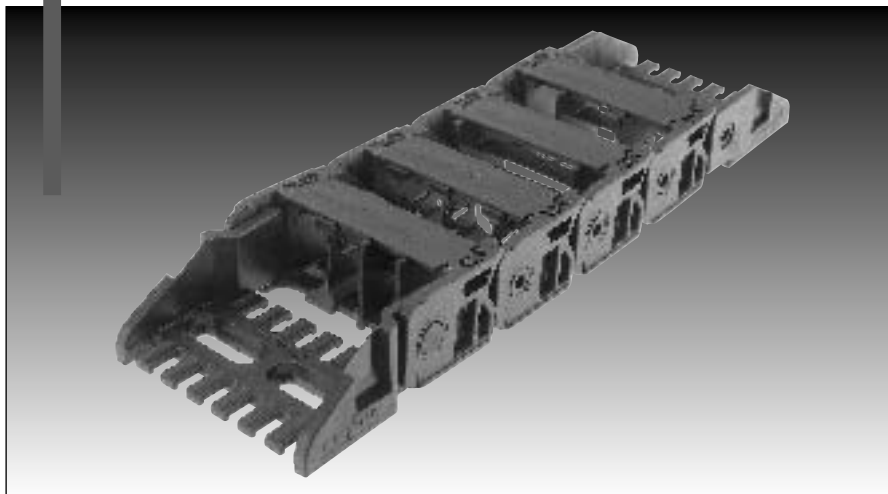

MultiLine

MP 3000



Order variants

Style (order code)						
Configuration (order code)						
Radius (order code) <small>The radii can be combined with any internal width</small>						
in inch						
Internal width (order code)						
in inch						
Outside width						
in inch						
MP3001	1.73	1.02	026			
MP3002	2.17	1.46	037	1.97	050	
MP3002.5	2.91	2.20	056	2.76	070	
MP3003	3.15	2.44	062	3.74	095	
MP3003.5	3.70	2.99	076	4.72	120	
MP3004	4.13	3.43	087	5.91	150	
MP3005	4.69	3.98	101	7.87	200	0
MP3006	5.63	4.92	125	11.81	300	1

Order-Number:	0300			0			0
---------------	-------------	--	--	----------	--	--	----------

Configuration:

0 PA crossbar every link; w/bias
 1 PA crossbar every link; w/o bias

Style:

0 Standard (PA/black)
 1 UL94/V0 (PA/oxide red)
 5 Polypropylene (PP/blue)
 7 ESD (PA/light gray)
 9 Custom version

Sample order:

0300 026 050 0000

Internal width = 1.02 in (26 mm)
 Radius = 1.97 in (50 mm)
 Configuration = 0
 Style = 0

Ideal operating conditions:

- Compact dimensions with opening cover in inside bend
- Quiet operation
- High stability
- Flexible internal separation
- Rotated 90° unsupported
- Version with bias (RV) for greater self-supporting length
- Version with bias (RV) for gliding arrangement

Alternative chain type:

- MP 25 G closed series
- MP 32 can be opened on both sides
- MP 32 variable widths
- MP 32 greater stresses
- MP 32 flange connection (KA-F)
- MP 32 reverse radii

Features

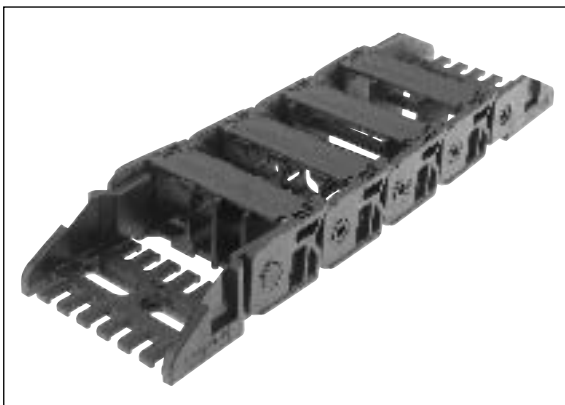

- Radii with or without bias (RV/RK)
- Reverse radius combinations
- Integrable separator for cable separation
- Chain bracket with metal inserts and strain relief
- Plug-in shelf system for reliable cable guidance
- ESD cable drag chains for use in areas at risk of explosion
- H-shelf for simple cable separation in the chain compartment
- ESD cable drag chains for use in areas of electrostatic discharge
- Crossbars, folding on one side
- Strain relief plate ZL

Technical data

Chain link dimensions (inch) (mm)

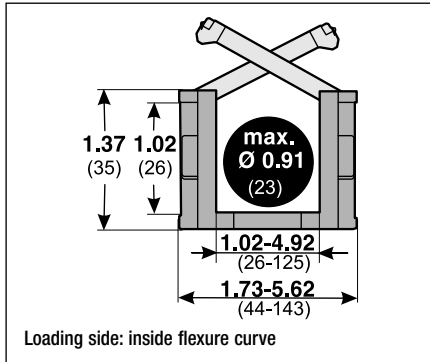

Material characteristics standard (PA/black)

Operating temperature: -22 to 248° F
 Gliding friction factor: 0.30
 Static friction factor: 0.45
 Fire classification: Based on UL94 HB

Other material properties on request

Technical specifications

Travel distance, gliding, L_g : 196.85 ft
 Travel distance, self-supporting, L_s : see diagram
 Travel distance, vertical, hanging, L_{vn} : 131.23 ft
 Travel distance, vertical, upright, L_{vs} : 9.84 ft
 Rotated 90°, self-supporting, L_{90r} : 2.30 ft
 Speed, gliding, V_g : 9.84 ft/s
 Speed, self-supporting, V_s : 19.69 ft/s
 Acceleration, gliding, a_g : 32.81 ft/s²
 Acceleration, self-supporting, a_s : 49.21 ft/s²

Self-supporting length

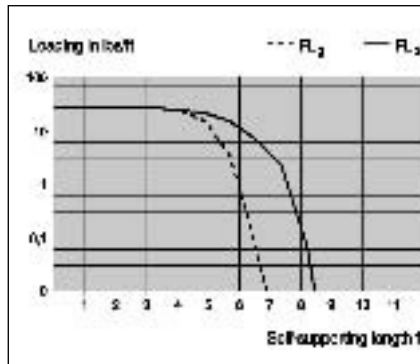
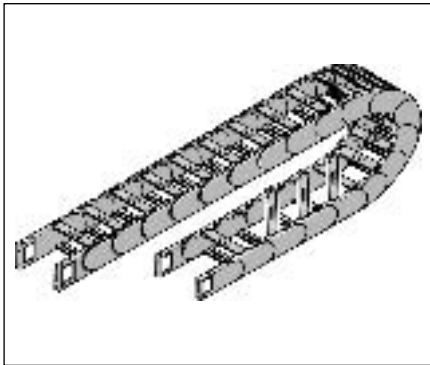

FL₁:
 Ideal installation situation for high stresses at the limit of the max. travel parameters. In this range the chain upper run is still biased, straight or has a max. sag of 0.39 – 1.97 in (10 – 50 mm) depending on the type of chain.

FL₂:
 Satisfactory installation position for many applications working in the lower to middle range of the max. travel parameters. Depending on the chain type, the sag of the chain upper run is >0.39 – 1.97 in (>10 – 50 mm) but certainly less than the max. sag.

If the sag is greater than FL₂, the arrangement is unsuitable and should be avoided. Please choose a more stable Murrplastik cable drag chain.

Determining the chain length

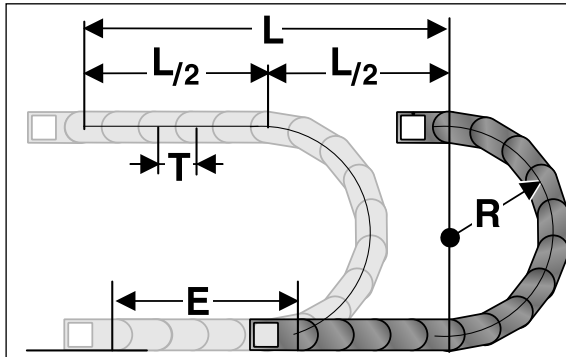

L = Travel distance
 R = Radius
 T = Pitch
 E = Distance between entry point and middle of travel distance

Determining the chain length

$$\text{Length} = \frac{L}{2} + \pi \times R + 2 \times T + E$$

≈ 1 ft(m) chain = 7(22) links each 1.77 in (45 mm)

The fixed point of the cable drag chain should be connected in the middle of the travel distance. This arrangement gives the shortest connection between the fixed point and the moving point and thus the most efficient chain length.

Installation dimensions (in inch)

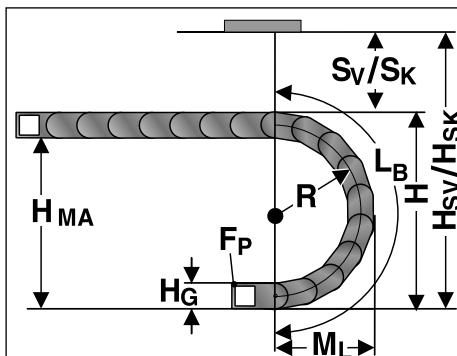

Radius R	1.97	2.76	3.74	4.72	5.91	7.87	11.81
Outside height of chain link (H_o)	1.38	1.38	1.38	1.38	1.38	1.38	1.38
Height of bend (H)	5.31	6.89	8.86	10.83	13.19	17.28	25.00
Height of moving end connection (H_{Ma})	3.94	5.51	7.48	9.45	11.81	15.75	23.62
Safety margin with bias (S_v)	1.77	1.77	1.77	1.77	1.77	1.77	1.77
Installation height with bias (H_{sv})	7.09	8.66	10.63	12.60	14.96	18.90	26.77
Safety margin without bias (S_k)	0.39	0.39	0.39	0.39	0.39	0.39	0.39
Installation height without bias (H_{sk})	5.71	7.28	9.25	11.22	13.58	17.52	25.39
Arc projection (M_l)	4.41	5.20	6.22	7.17	8.35	10.31	14.25
Bend length (L_b)	10.12	12.60	15.67	18.78	22.48	28.66	41.02



Chain bracket

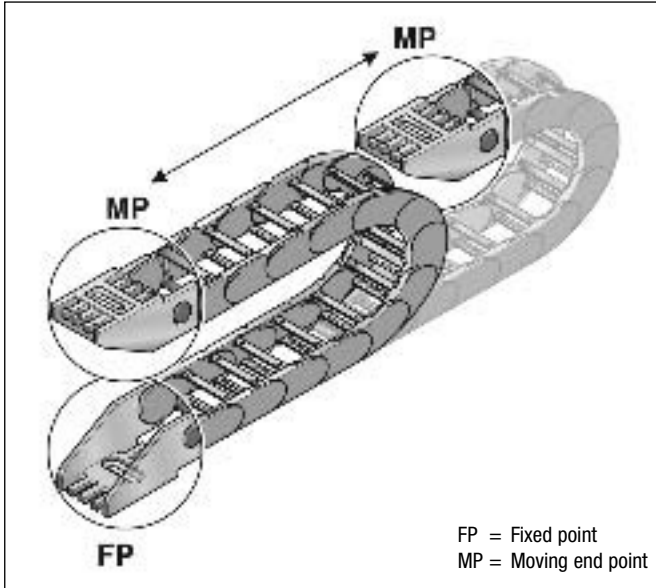

Chain bracket U-part



Top

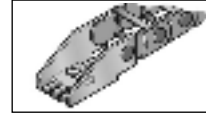

Bottom

Chain bracket angle



Bottom/Outside

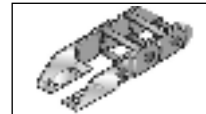

Bottom/Inside

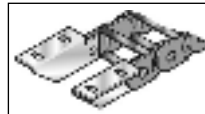

Top/Outside

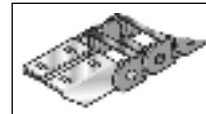

Top/Inside

Chain bracket U-part

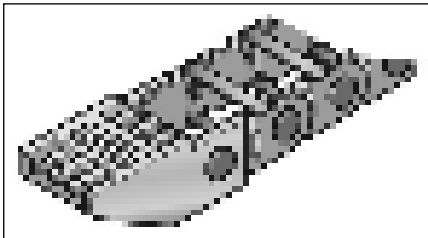

KA/Z 3...

Type	Order no.		Pack qty.
KA/Z 3001 female end	030000008000	for inside width 1.02 in (26 mm)	1
KA/Z 3001 male end	030000008100	for inside width 1.02 in (26 mm)	1
KA/Z 3002 female end	030000008200	for inside width 1.46 in (37 mm)	1
KA/Z 3002 male end	030000008300	for inside width 1.46 in (37 mm)	1
KA/Z 3002.5 female end	030000007600	for inside width 2.20 in (56 mm)	1
KA/Z 3002.5 male end	030000007700	for inside width 2.20 in (56 mm)	1
KA/Z 3003 female end	030000008400	for inside width 2.44 in (62 mm)	1
KA/Z 3003 male end	030000008500	for inside width 2.44 in (62 mm)	1
KA/Z 3003.5 female end	030000007800	for inside width 2.99 in (76 mm)	1
KA/Z 3003.5 male end	030000007900	for inside width 2.99 in (76 mm)	1
KA/Z 3004 female end	030000008600	for inside width 3.43 in (87 mm)	1
KA/Z 3004 male end	030000008700	for inside width 3.43 in (87 mm)	1
KA/Z 3005 female end	030000008800	for inside width 3.98 in (101 mm)	1
KA/Z 3005 male end	030000008900	for inside width 3.98 in (101 mm)	1
KA/Z 3006 female end	030000009300	for inside width 4.92 in (125 mm)	1
KA/Z 3006 male end	030000009400	for inside width 4.92 in (125 mm)	1

The chain bracket, type KA/Z 3001–3006, is a plastic part with extrusion-coated metal insert. The bracket is precisely adjusted to the respective chain width and only needs to be snapped in at the chain link. Please order one male and one female end bracket for each chain. The brackets should be fastened with M6 screws. The cables or tubes may be fastened with cable ties at the integrated strain relief of the chain bracket.

Chain bracket angle

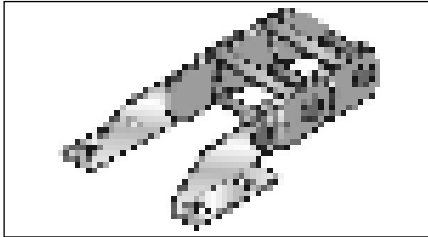

KA 3...

Type	Order no.	Material	Pack qty.
KA 3008 Female end	0300000052	Sheet steel	1
KA 3008 Male end	0300000053	Sheet steel	1
KA 3009 Female end	0300000054	Stainless steel 1.4301	1
KA 3009 Male end	0300000055	Stainless steel 1.4301	1

Please order one female end (left hole + right hole) and one male end (left bolt + right bolt) for each chain.

Chain bracket U-part

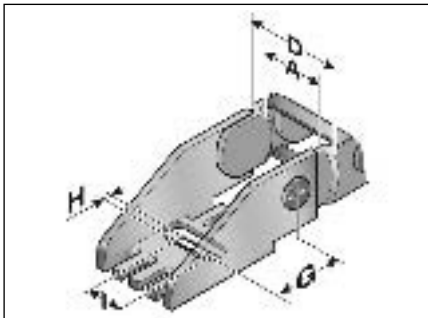

KA/Z 3001

Type	A inch	D inch	G inch	H Ø inch	I inch
KA/Z 3001	1.02	1.73	1.24	0.26	0.73

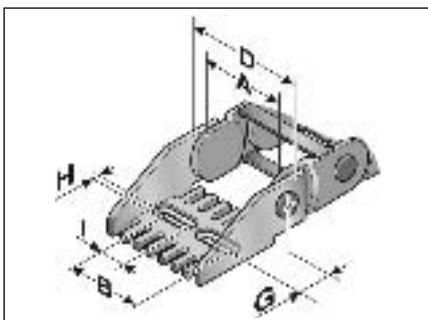

KA/Z 3002-3006

Type	A inch	B inch	D inch	G inch	H Ø inch	I inch
KA/Z 3002	1.46	1.18	2.17	1.24	0.26	0.30
KA/Z 3002.5	2.20	1.89	2.91	1.24	0.26	0.30
KA/Z 3003	2.44	2.17	3.15	1.24	0.26	0.73
KA/Z 3003.5	2.99	2.68	3.70	1.24	0.26	0.73
KA/Z 3004	3.43	3.15	4.13	1.24	0.26	0.73
KA/Z 3005	3.98	3.70	4.69	1.24	0.26	0.73
KA/Z 3006	4.92	4.67	5.71	1.24	0.26	0.73



Chain bracket angle

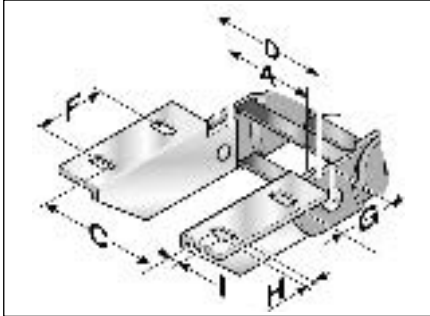

Bottom and top/outside

Type	A inch	C inch	D inch	F inch	G inch	H Ø inch	I inch
KA 3008 Female end	1.02	1.91	1.73	0.98	0.83	0.26	0.18
KA 3008 Male end	1.02	2.24	1.73	0.98	0.83	0.26	0.18
KA 3008 Female end	1.46	2.34	2.17	0.98	0.83	0.26	0.18
KA 3008 Male end	1.46	2.68	2.17	0.98	0.83	0.26	0.18
KA 3008 Female end	2.20	3.09	2.91	0.98	0.83	0.26	0.18
KA 3008 Male end	2.20	3.43	2.93	0.98	0.83	0.26	0.18
KA 3008 Female end	2.44	3.33	3.15	0.98	0.83	0.26	0.18
KA 3008 Male end	2.44	3.66	3.15	0.98	0.83	0.26	0.18
KA 3008 Female end	2.99	3.88	3.70	0.98	0.83	0.26	0.18
KA 3008 Male end	2.99	4.21	3.70	0.98	0.83	0.26	0.18
KA 3008 Female end	3.43	4.31	4.15	0.98	0.83	0.26	0.18
KA 3008 Male end	3.43	4.65	4.13	0.98	0.83	0.26	0.18
KA 3008 Female end	3.98	4.86	4.70	0.98	0.83	0.26	0.18
KA 3008 Male end	3.98	5.20	4.69	0.98	0.83	0.26	0.18
KA 3008 Female end	4.92	5.81	5.71	0.98	0.83	0.26	0.18
KA 3008 Male end	4.92	6.14	5.71	0.98	0.83	0.26	0.18

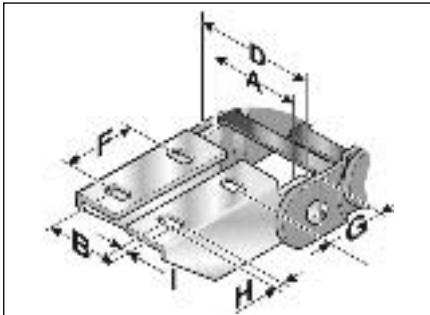

Bottom and top/inside

Type	A inch	B inch	D inch	F inch	G inch	H Ø inch	I inch
KA 3008 Female end	1.46	1.12	2.17	0.98	0.83	0.26	0.18
KA 3008 Male end	1.46	1.32	2.17	0.98	0.83	0.26	0.18
KA 3008 Female end	2.20	1.87	2.91	0.98	0.83	0.26	0.18
KA 3008 Male end	2.20	2.07	2.91	0.98	0.83	0.26	0.18
KA 3008 Female end	2.44	2.11	3.15	0.98	0.83	0.26	0.18
KA 3008 Male end	2.44	2.30	3.15	0.98	0.83	0.26	0.18
KA 3008 Female end	2.99	2.66	3.70	0.98	0.83	0.26	0.18
KA 3008 Male end	2.99	2.85	3.70	0.98	0.83	0.26	0.18
KA 3008 Female end	3.43	3.09	4.13	0.98	0.83	0.26	0.18
KA 3008 Male end	3.43	3.29	4.13	0.98	0.83	0.26	0.18
KA 3008 Female end	3.98	3.64	4.69	0.98	0.83	0.26	0.18
KA 3008 Male end	3.98	3.84	4.69	0.98	0.83	0.26	0.18
KA 3008 Female end	4.92	4.59	5.71	0.98	0.83	0.26	0.18
KA 3008 Male end	4.92	4.78	5.71	0.98	0.83	0.26	0.18

Separator

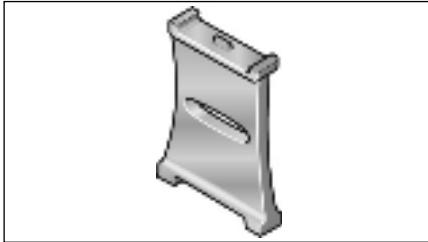

Separator

Type	Order no.	Designation	Pitch inch	Version	Pack qty.
TR 3000	030000009000	Separator	0.12	moveable	1
TR 3001	030000009200	Separator	0.12	moveable/lockable	1

We recommend that separators be used if multiple round cables or conduits with differing diameters are to be installed. An offset configuration of the separators is advisable. The lockable separator must be used for side-mounted cable drag chains to prevent the separator from slipping down.

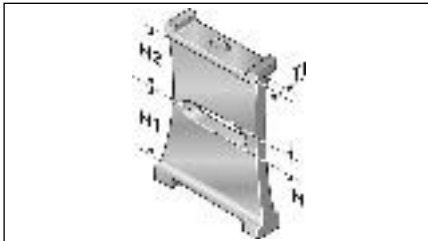

Separator

Type	TI inch	H inch	H1 inch	H2 inch
TR 3000	0.06	0.10	0.51	0.51
TR 3001	0.06	0.10	0.51	0.51

H-shaped shelf unit

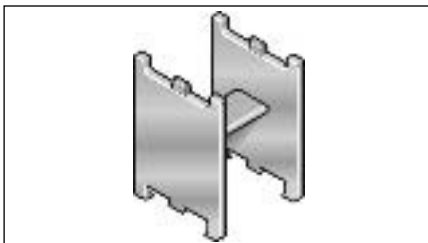

H-shaped shelf unit

Type	Order no.	Designation	Pitch inch	Pack qty.
RE 26/15	100000261510	RE 26/15 H-shaped shelf unit	0.12	1
RE 26/27	100000262710	RE 26/27 H-shaped shelf unit	0.12	1
RE 26/51	100000265110	RE 26/51 H-shaped shelf unit	0.12	1

Insert to obtain additional levels in pre-defined distances.

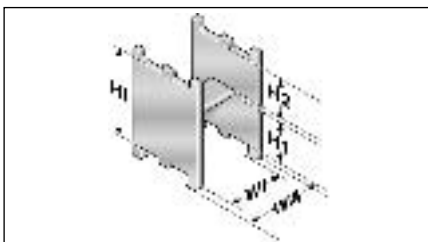

H-shaped shelf unit

Type	WA inch	WI inch	H1 inch	H2 inch	HI inch
RE 26/15	0.69	0.49	0.54	0.38	1.02
RE 26/27	1.16	0.96	0.54	0.38	1.02
RE 26/51	2.11	1.91	0.54	0.38	1.02



MP 3000 - Accessories

Shelving system

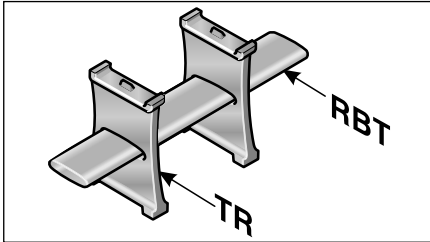

Shelving system

Type	Order no.	Designation	Width inch	Pitch inch	Pack qty.
RBT 037	100000003700	RBT 037 shelf	1.46	0.12	1
RBT 062	100000006200	RBT 062 shelf	2.44	0.12	1
RBT 086	100000008600	RBT 086 shelf	3.39	0.12	1
RBT 101	100000010100	RBT 101 shelf	3.98	0.12	1

The shelf must be used with a minimum of two separators to create a shelving system. The additional levels prevent cables from criss-crossing and therefore destroying each other, while also avoiding excessive friction. The shelves are matched to the available chain widths.

Assembly

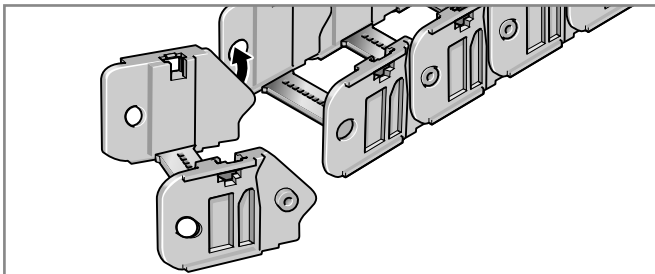

Step 1

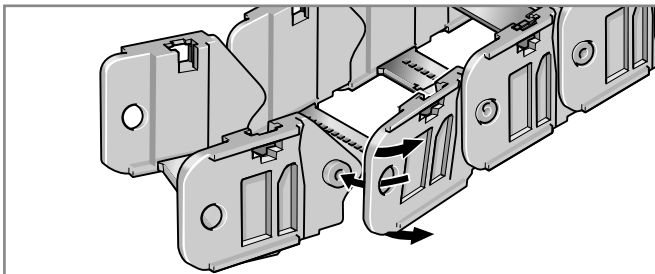

Step 2

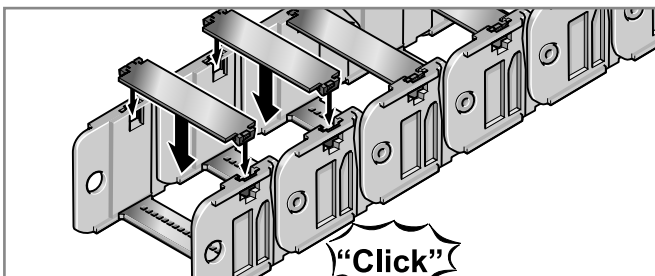

Step 3

Disassembly

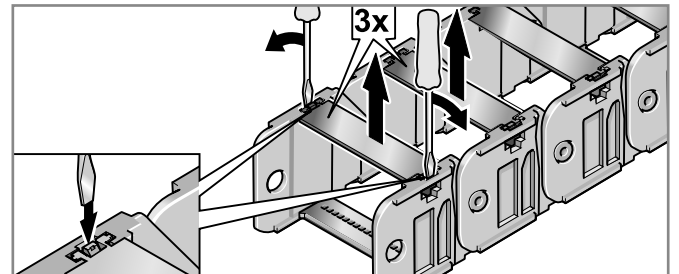

Step 1

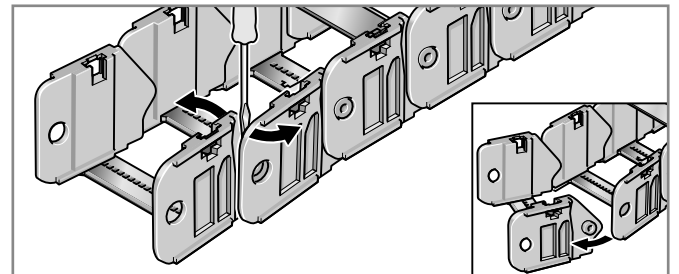

Step 2

Cable drag chain systems

PowerLine

MP 32

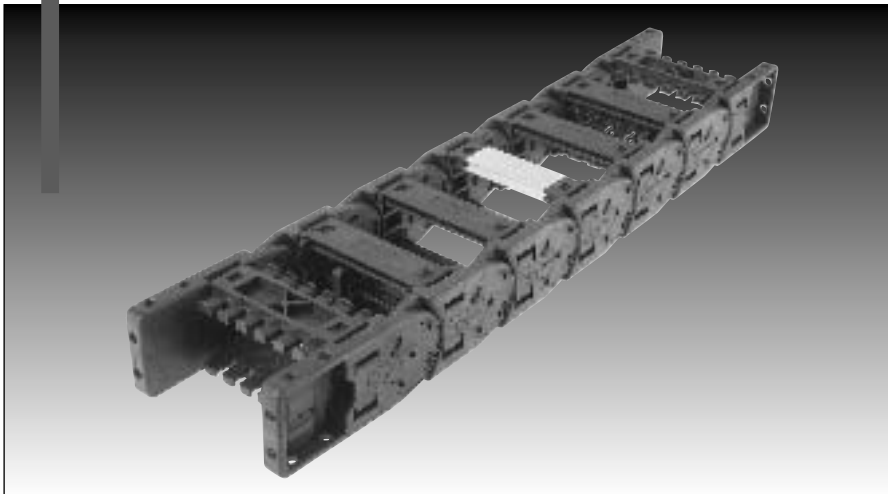



MP 32 - PowerLine

Order variants

Style (order code)						
Configuration (order code) * = standard						
Radius (order code) <small>The radii can be combined with any internal width</small>						
in inch						
Internal width (order code)						
in inch						
Outside width (order code)						
in inch						
MP32 045	2.80	1.77	045			
MP32 062	3.46	2.44	062			
MP32 071	3.82	2.80	071			
MP32 084	4.33	3.31	084			
MP32 096	4.80	3.78	096			
MP32 107	5.24	4.21	107			
MP32 121	5.79	4.76	121			
MP32 133	6.26	5.24	133			
MP32 144	6.69	5.67	144			
MP32 146	6.77	5.75	146			
MP32 158	7.24	6.22	158			
MP32 171	7.76	6.73	171			
MP32 182	8.19	7.17	182			
MP32 196	8.74	7.72	196			
MP32 220	9.69	8.66	220			
MP32 246	10.71	9.69	246			
MP32 296	12.68	11.65	296			
MP32 346	14.65	13.62	346			
MP32 396	16.61	15.59	396	3.15	080	
MP32 446	18.58	17.56	446	3.94	100	0
MP32 496	20.55	19.53	496	4.72	120	2*
MP32 546	22.52	21.50	546	5.91	150	4
MP32 xxx	inside	>3.15		7.87	200	6
	+ 1.02	-23.62	Alu	9.84	250	9
						0
						2*
						4
						6
						9

Order-Number:

Configuration:

- 0 PA crossbar every link; w/bias
- 2* PA crossbar EOL; w/bias
- 4 AL crossbar every link; w/bias
- 6 AL crossbar EOL; w/bias
- 9 Custom version

Style:

- 0 Standard (PA/black)
- 9 Custom version

Sample order:

0320 045 080 0000

Internal width = 1.77 in (45 mm)
 Radius = 3.15 in (80 mm)
 Configuration = 0
 Style = 0

Ideal operating conditions:

- Extreme accelerations
- Extreme speeds
- Extreme self-supporting lengths
- Very high additional loads
- Both sides must be opened
- Aluminum frame bridge in variable lengths
- Flexible internal separation
- Rotated 90° unsupported
- Rotated 90° horizontal

Alternative chain type:

- MP 36 G closed series
- MP 18. opening cover in inside bend
- MP 35 easier to use

Features

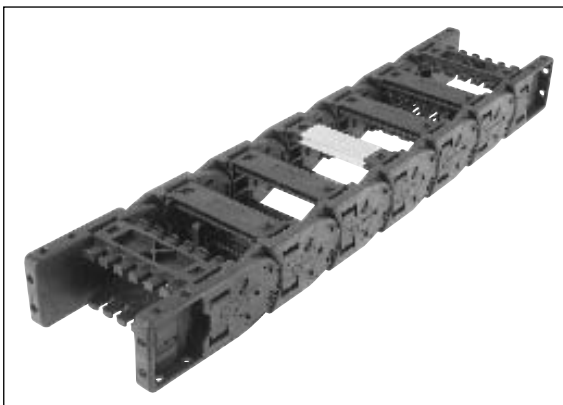

- Chain bracket, can be fastened on three sides
- Crossbar/cover can be removed from inside and outside flexure curve
- Reverse radius combinations
- Foldable shelf system for reliable cable guidance
- Crossbar connector for securing of large frame bridge widths
- Crossbar strain relief can be integrated into chain bracket
- Radii with medium bias (R) for all applications
- Aluminum frame bridges with integrated lock grid in variable lengths
- Integrable separator for cable separation

Technical data

Chain link dimensions (inch) (mm)

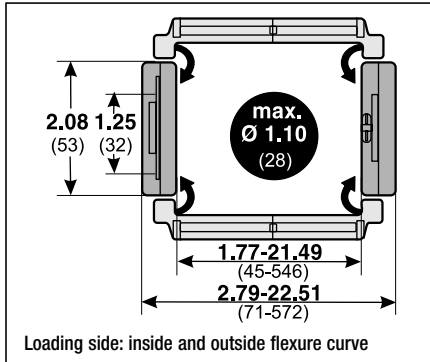

Material characteristics standard (PA/black)

Operating temperature:	-22 to 248° F
Gliding friction factor:	0.30
Static friction factor:	0.45
Fire classification:	Based on UL94 HB
Other material properties on request	

Technical specifications

Travel distance, gliding, L_g :	328.08 ft
Travel distance, self-supporting, L_s :	see diagram
Travel distance, vertical, hanging, L_{vs} :	196.85 ft
Travel distance, vertical, upright, L_{vs} :	16.40 ft
Rotated 90°, self-supporting, L_{90r} :	6.56 ft
Speed, gliding, V_g :	16.40 ft/s
Speed, self-supporting, V_s :	65.62 ft/s
Acceleration, gliding, a_g :	82.02 ft/s ²
Acceleration, self-supporting, a_s :	98.43 ft/s ²

Self-supporting length

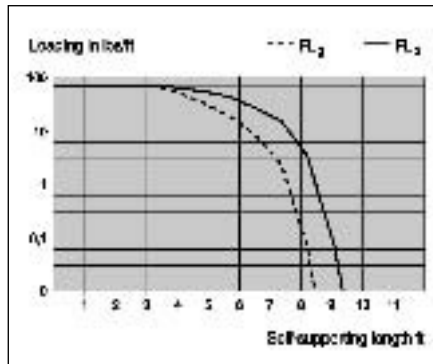
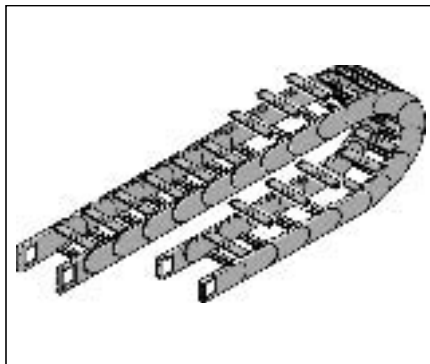

FL_g:
Ideal installation situation for high stresses at the limit of the max. travel parameters. In this range the chain upper run is still biased, straight or has a max. sag of 0.39 – 1.97 in (10 – 50 mm) depending on the type of chain.

FL_s:
Satisfactory installation position for many applications working in the lower to middle range of the max. travel parameters. Depending on the chain type, the sag of the chain upper run is >0.39 – 1.97 in (>10 – 50 mm) but certainly less than the max. sag.

If the sag is greater than FL_s, the arrangement is unsuitable and should be avoided. Please choose a more stable Murrplastik cable drag chain.

Determining the chain length

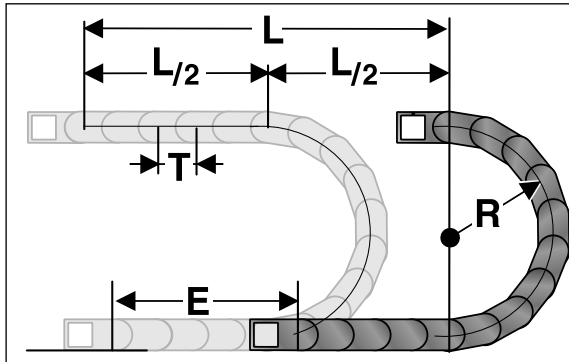

L = Travel distance
R = Radius
T = Pitch
E = Distance between entry point and middle of travel distance

Determining the chain length

$$\text{Length} = \frac{L}{2} + \pi \times R + E$$

≈ 1 ft(m) chain = 5(16) links each 2.54 in (64,5 mm)

The fixed point of the cable drag chain should be connected in the middle of the travel distance. This arrangement gives the shortest connection between the fixed point and the moving point and thus the most efficient chain length.

Installation dimensions (in inch)

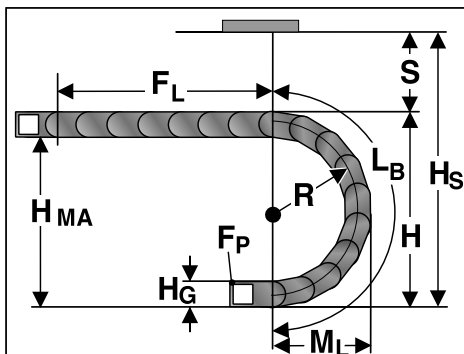

Radius R	3.15	3.94	4.72	5.91	7.87	9.84
Outside height of chain link (H_0)	2.09	2.09	2.09	2.09	2.09	2.09
Height of bend (H)	9.17	10.75	12.32	14.69	18.62	22.56
Height of moving end connection (H_{MA})	7.09	8.66	10.24	12.60	16.54	20.47
Safety margin (S)	1.18	1.18	1.18	1.18	1.18	1.18
Installation height (H_s)	10.35	11.93	13.50	15.87	19.80	23.74
Arc projection (M_L)	7.13	7.91	8.70	9.88	11.85	13.82
Bend length (L_b)	16.93	19.41	21.89	25.59	31.77	37.95



Chain bracket

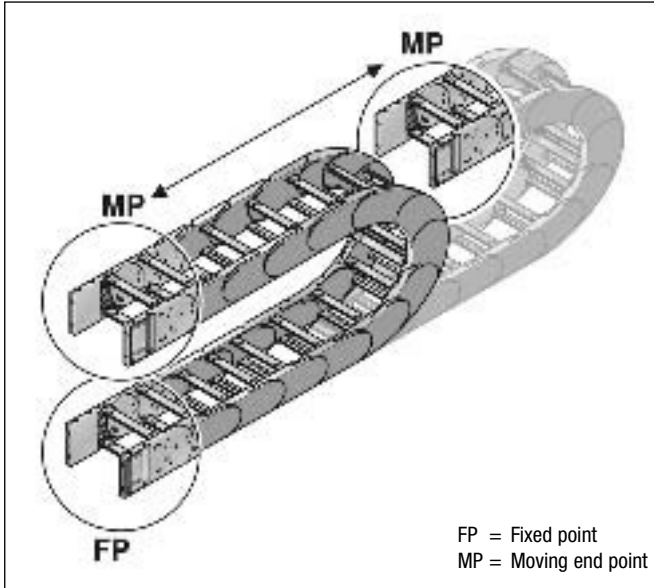

Flexible chain bracket

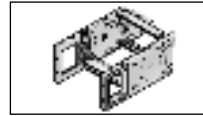

Flexible

Flexible chain bracket

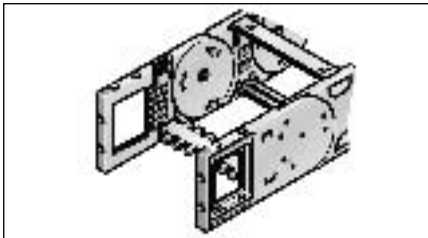

KA 32...

Type	Order no.	Version	Pack qty.
KA 32-FB	0321000054	with bushing	1
KA 32-FG	0321000055	with thread	1

This chain bracket offers universal connection options (top, bottom and front) and is attached to the ends of the chain like a side link. This allows the chain to move right up to the bracket. Each chain requires one male and one female bracket. M5 screws are used to secure the brackets in place. Extrusion-coated metal bushings with either a through-hole (-FB) or a threaded hole (-FG) ensure the permanent, high-strength transmission of even extreme forces onto the cable drag chain.

Flexible chain bracket

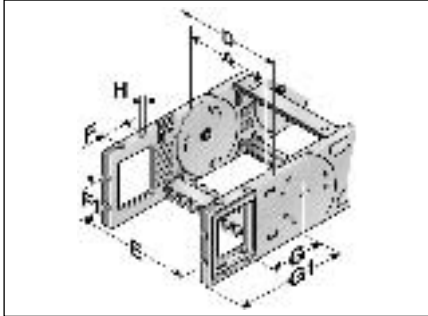

Flexible with through-hole (KA 32-FB)

Type	A inch	D inch	E inch	F inch	F1 inch	G inch	G1 inch	H Ø inch
KA 32-FB	1.77	2.80	2.32	0.89	0.87	2.28	3.66	0.22
KA 32-FB	2.44	3.46	2.99	0.89	0.87	2.28	3.66	0.22
KA 32-FB	2.80	3.82	3.35	0.89	0.87	2.28	3.66	0.22
KA 32-FB	3.31	4.33	3.86	0.89	0.87	2.28	3.66	0.22
KA 32-FB	3.78	4.80	4.33	0.89	0.87	2.28	3.66	0.22
KA 32-FB	4.21	5.24	4.76	0.89	0.87	2.28	3.66	0.22
KA 32-FB	4.76	5.79	5.31	0.89	0.87	2.28	3.66	0.22
KA 32-FB	5.24	6.26	5.79	0.89	0.87	2.28	3.66	0.22
KA 32-FB	5.67	6.69	6.22	0.89	0.87	2.28	3.66	0.22
KA 32-FB	5.75	6.77	6.30	0.89	0.87	2.28	3.66	0.22
KA 32-FB	6.22	7.24	6.77	0.89	0.87	2.28	3.66	0.22
KA 32-FB	6.73	7.76	7.28	0.89	0.87	2.28	3.66	0.22
KA 32-FB	7.17	8.19	7.72	0.89	0.87	2.28	3.66	0.22
KA 32-FB	7.72	8.74	8.27	0.89	0.87	2.28	3.66	0.22
KA 32-FB	8.66	9.69	9.21	0.89	0.87	2.28	3.66	0.22
KA 32-FB	9.69	10.71	10.24	0.89	0.87	2.28	3.66	0.22
KA 32-FB	11.65	12.68	12.20	0.89	0.87	2.28	3.66	0.22
KA 32-FB	13.62	14.65	14.17	0.89	0.87	2.28	3.66	0.22
KA 32-FB	15.59	16.61	16.14	0.89	0.87	2.28	3.66	0.22
KA 32-FB	17.56	18.58	18.11	0.89	0.87	2.28	3.66	0.22
KA 32-FB	19.53	20.55	20.08	0.89	0.87	2.28	3.66	0.22
KA 32-FB	21.50	22.52	22.05	0.89	0.87	2.28	3.66	0.22

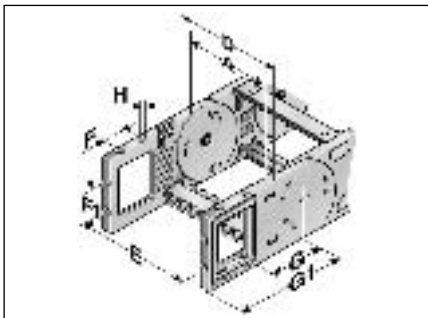

Flexible with with threaded bushing (KA 32-FG)

Type	A inch	D inch	E inch	F inch	F1 inch	G inch	G1 inch	H
KA 32-FG	1.77	2.80	2.32	0.89	0.87	2.28	3.66	M5
KA 32-FG	2.44	3.46	2.99	0.89	0.87	2.28	3.66	M5
KA 32-FG	2.80	3.82	3.35	0.89	0.87	2.28	3.66	M5
KA 32-FG	3.31	4.33	3.86	0.89	0.87	2.28	3.66	M5
KA 32-FG	3.78	4.80	4.33	0.89	0.87	2.28	3.66	M5
KA 32-FG	4.21	5.24	4.76	0.89	0.87	2.28	3.66	M5
KA 32-FG	4.76	5.79	5.31	0.89	0.87	2.28	3.66	M5
KA 32-FG	5.24	6.26	5.79	0.89	0.87	2.28	3.66	M5
KA 32-FG	5.67	6.69	6.22	0.89	0.87	2.28	3.66	M5
KA 32-FG	5.75	6.77	6.30	0.89	0.87	2.28	3.66	M5
KA 32-FG	6.22	7.24	6.77	0.89	0.87	2.28	3.66	M5
KA 32-FG	6.73	7.76	7.28	0.89	0.87	2.28	3.66	M5
KA 32-FG	7.17	8.19	7.72	0.89	0.87	2.28	3.66	M5
KA 32-FG	7.72	8.74	8.27	0.89	0.87	2.28	3.66	M5
KA 32-FG	8.66	9.69	9.21	0.89	0.87	2.28	3.66	M5
KA 32-FG	9.69	10.71	10.24	0.89	0.87	2.28	3.66	M5
KA 32-FG	11.65	12.68	12.20	0.89	0.87	2.28	3.66	M5
KA 32-FG	13.62	14.65	14.17	0.89	0.87	2.28	3.66	M5
KA 32-FG	15.59	16.61	16.14	0.89	0.87	2.28	3.66	M5
KA 32-FG	17.56	18.58	18.11	0.89	0.87	2.28	3.66	M5
KA 32-FG	19.53	20.55	20.08	0.89	0.87	2.28	3.66	M5
KA 32-FG	21.50	22.52	22.05	0.89	0.87	2.28	3.66	M5



Assembly instruction flexible chain bracket

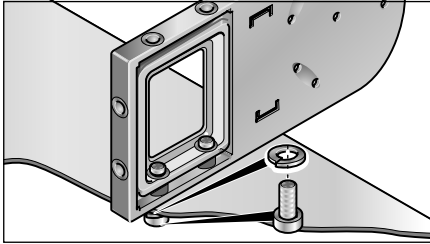

Chain bracket with threaded bushing

Brass bushings guarantee long-lasting fastening without cold flow in the plastic.

Version KA-FB:

Integrated through-hole fastened down using screw and nut.

Version KA-FG:

Built-in threads allow for quick and easy on-site mounting, since a screw, including a retaining washer where necessary, is sufficient.

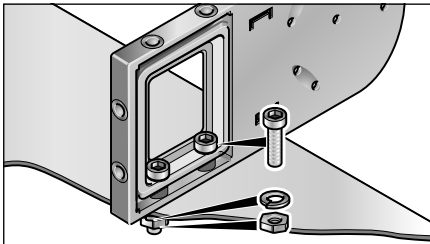

Chain bracket with bushing

Separator



Separator

Type	Order no.	Designation	Pitch inch	Pack qty.
TR 32	032000009200	Separator	0.22	1

We recommend that separators be used if multiple round cables or conduits with differing diameters are to be installed. An offset configuration of the separators is advisable.

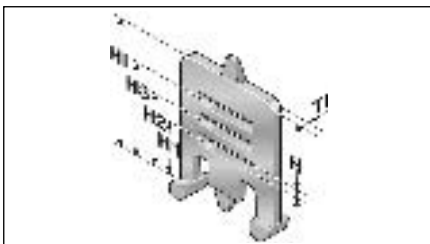

Separator

Type	T1 inch	H inch	H1 inch	H2 inch	H3 inch	H1 inch
TR 32	0.12	0.17	0.41	0.64	0.87	1.28

H-shaped shelf unit

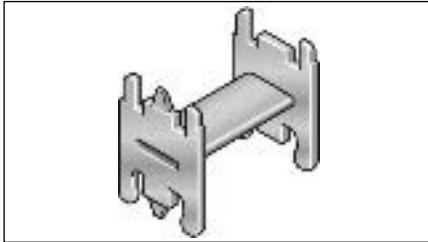

H-shaped shelf unit

Type	Order no.	Designation	Pitch inch	Pack qty.
RE 32/35	100000322010	RE 32/35 H-shaped shelf unit	0.22	1
RE 32/52	100000323510	RE 32/52 H-shaped shelf unit	0.22	1
RE 32/75	100000327510	RE 32/75 H-shaped shelf unit	0.22	1

Insert to obtain additional levels in pre-defined distances.

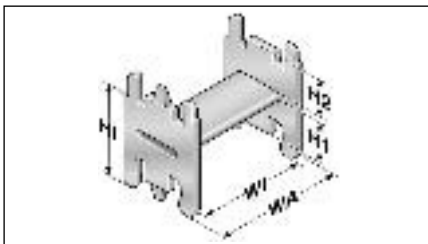

H-shaped shelf unit

Type	WA inch	WI inch	H1 inch	H2 inch	HI inch
RE 32/35	1.70	1.39	0.56	0.56	1.28
RE 32/52	2.36	2.05	0.56	0.56	1.28
RE 32/75	3.24	2.93	0.65	0.47	1.28

Shelving system

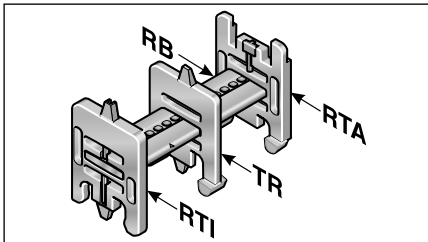

Shelving system

Type	Order no.	Designation	Width inch	Pitch inch	Pack qty.
RB 031	100000003100	RB 031 Shelf	1.22	0.22	1
RB 048	100000004800	RB 048 Shelf	1.89	0.22	1
RB 070	100000007000	RB 070 Shelf	2.76	0.22	1
RB 092	100000009200	RB 092 Shelf	3.62	0.22	1
RB 100	100000010000	RB 100 Shelf	3.94	0.22	1
RB 128	100000012800	RB 128 Shelf	5.04	0.22	1
RB 167	100000016700	RB 167 Shelf	6.57	0.22	1
RB 218	100000021800	RB 218 Shelf	8.58	0.22	1
RTA 32	1000910100	RTA 32 Shelf support, external, incl. pin		0.22	1
RTI 32	1000911100	RTI 32 Shelf support, internal, incl. pin		0.22	1

In connection with at least two shelf supports (RTI/RTA) the shelf becomes a shelving system. The additional levels prevent cables from criss-crossing and therefore destroying each other, while also avoiding excessive friction. The shelf system can be pre-assembled on request.

RTA shelf supports are positioned on the outer edge of the internal chain compartment.

RTI shelf supports are positioned in the center of the internal chain compartment in case the shelf system does not span the entire width.

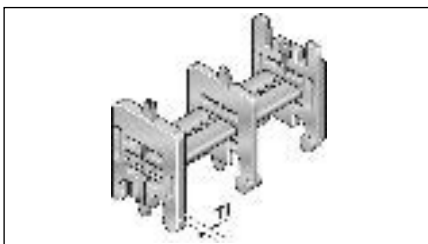

Shelving system

Type	TI inch
RTA/RTI	0.24



Crossbar connector

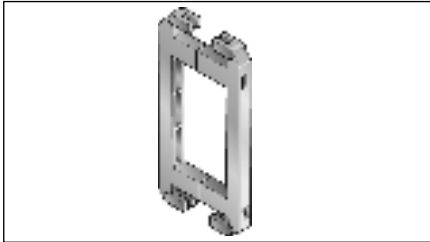

Crossbar connector

Type	Order no.	Designation	Pack qty.
RSV 32	032000009600	RSV 32 Crossbar connector	1
RSV 32 Alu	032000009800	RSV 32 Crossbar connector for aluminum crossbridges	1

For frame bridges wider than 9.69 in (246 mm), we recommend the use of crossbar connectors. These prevent deformation to the frame bridge under large amounts of additional weight of the chain assembly.

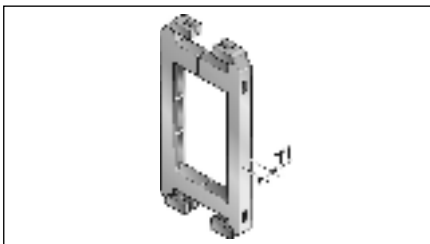

Type	TI inch
RSV 32	0.30
RSV 32 Alu	0.30

Crossbar strain relief plate RS-ZL

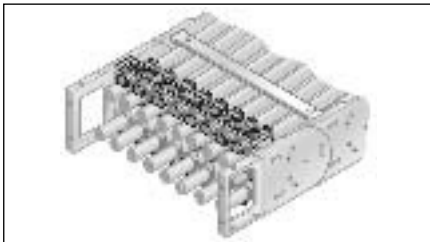

Crossbar strain relief plate RS-ZL

Type	Order no.	For internal width inch	Pack qty.
RS-ZL 045-5	052004500010	1.77	1
RS-ZL 062-5	052006200010	2.44	1
RS-ZL 071-5	052007100010	2.80	1
RS-ZL 084-5	052008400010	3.31	1
RS-ZL 096-5	052009600010	3.78	1
RS-ZL 107-5	052010700010	4.21	1
RS-ZL 121-5	052012100010	4.76	1
RS-ZL 133-5	052013300010	5.24	1
RS-ZL 5.67/5.75-5	052014400010	5.67/5.75	1
RS-ZL 158-5	052015800010	6.22	1
RS-ZL 171-5	052017100010	6.73	1
RS-ZL 182-5	052018200010	7.17	1
RS-ZL 196-5	052019600010	7.72	1
RS-ZL 220-5	052022000010	8.66	1
RS-ZL 246-5	052024600010	9.69	1

Fixed integrated frame bridge strain relief plates in the chain brackets. Tailored to all frame bridge widths up to 9.69 in (246 mm). May be assembled on the inside and outside flexure curves at both chain endings.

Strain relief type BAK

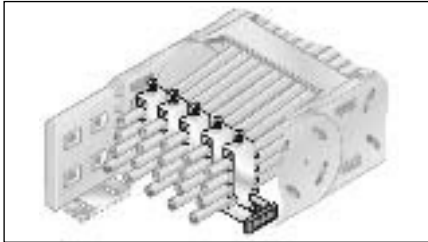

Strain relief with hooped clamp

Type	Order no.	Designation	Ø inch	Number of seats	Pack qty.
C-rail	81661610	C-profile rail			1
BA 12	81661036	BA 12 Hooped clamp	0.35–0.47	1	1
BAK 14	81661002	BAK 14 Hooped clamp	6–0.55	1	1
BAK 18	81661004	BAK 18 Hooped clamp	0.55–18	1	1
BAK 22	81661006	BAK 22 Hooped clamp	0.71–0.87	1	1
BAK 26	81661008	BAK 26 Hooped clamp	0.87–1.02	1	1
BAK 30	81661010	BAK 30 Hooped clamp	1.02–1.18	1	1
BAK 34	81661000	BAK 34 Hooped clamp	1.18–1.34	1	1
BAK 38	81661044	BAK 38 Hooped clamp	1.34–1.50	1	1
BAK 42	81661032	BAK 42 Hooped clamp	1.50–1.65	1	1
BAK 46	81661050	BAK 46 Hooped clamp	1.65–1.81	1	1
BA 12/2	81661038	BA 12/2 Hooped clamp	0.35–0.47	2	1
BAK 14/2	81661012	BAK 14/2 Hooped clamp	0.39–0.55	2	1
BAK 18/2	81661014	BAK 18/2 Hooped clamp	0.55–18	2	1
BAK 22/2	81661016	BAK 22/2 Hooped clamp	0.71–0.87	2	1
BAK 26/2	81661018	BAK 26/2 Hooped clamp	0.87–1.02	2	1
BAK 30/2	81661048	BAK 30/2 Hooped clamp	1.02–1.18	2	1
BAK 34/2	81661044	BAK 34/2 Hooped clamp	1.18–1.34	2	1
BAK 38/2	81661046	BAK 38/2 Hooped clamp	1.34–1.50	2	1
BAK 42/2	81661034	BAK 42/2 Hooped clamp	1.50–1.65	2	1
BAK 12/3	81661020	BAK 12/3 Hooped clamp	0.35–0.47	3	1
BAK 14/3	81661022	BAK 14/3 Hooped clamp	12–0.55	3	1
BAK 16/3	81661024	BAK 16/3 Hooped clamp	0.55–16	3	1
BAK 18/3	81661026	BAK 18/3 Hooped clamp	0.63–0.71	3	1
BAK 20/3	81661028	BAK 20/3 Hooped clamp	0.71–0.79	3	1
BAK 22/3	81661030	BAK 22/3 Hooped clamp	0.79–0.87	3	1

Fixed integrated strain relief in the chain connections. Available in all widths (also individual widths for aluminum frame ridges). May be assembled on the inside and outside flexure curves at both chain endings. Chain content is secured through hooped clamps that are available in different sizes. Material: Galvanized steel.

When ordering please indicate the type of chain and internal width.



Reverse radius

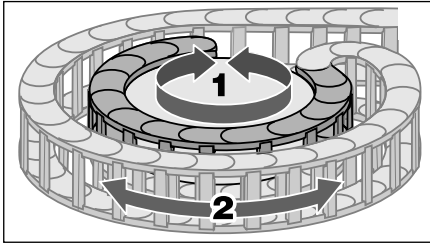

Rotating movement

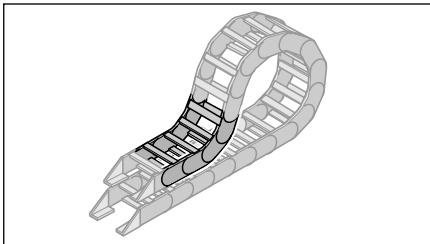

lowered chain bracket

Type	Order no.	Radius inch	Reverse radius inch	Pack qty.
SR 32 (RÜ200/R120)	32000008060	4.72	7.87	1
SR 32 (RÜ200/R135)	32000010060	5.31	7.87	1
SR 32 (RÜ200/R150)	32000012060	5.91	7.87	1
SR 32 (RÜ200/R170)	32000015060	6.69	7.87	1
SR 32 (RÜ200/R200)	32000020060	7.87	7.87	1
SR 32 (RÜ200/R250)	32000025060	9.84	7.87	1

Side links with radius forward (R) and radius backward (Rü) allow for movement in two directions. This is intended for rotating movements and lowered chain brackets.

Assembly

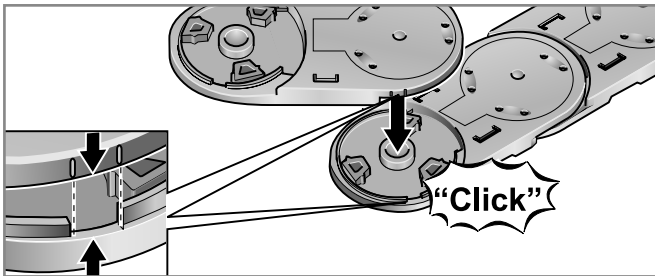

Step 1

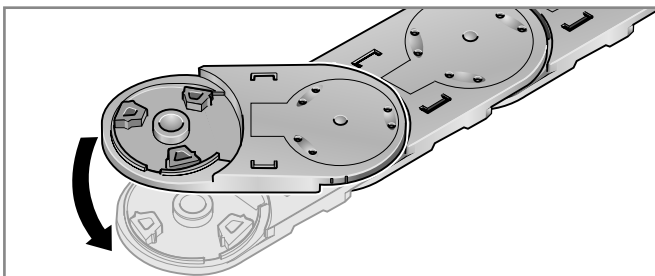

Step 2

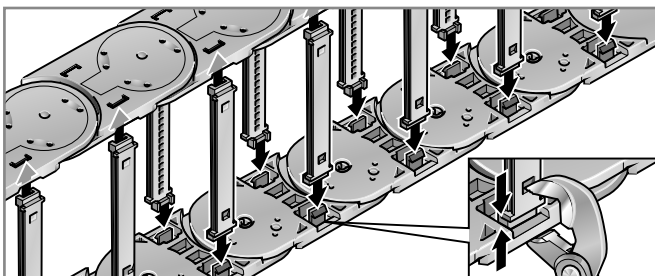

Step 3

Disassembly

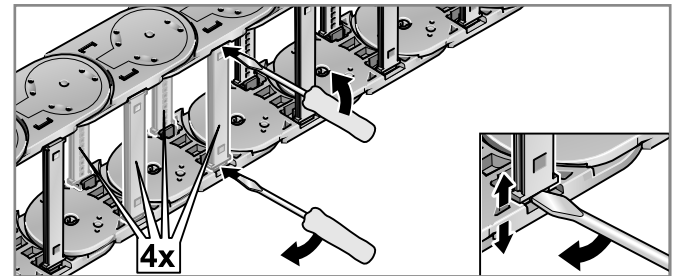

Step 1

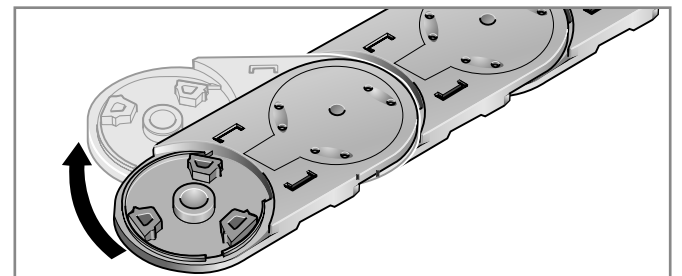

Step 2

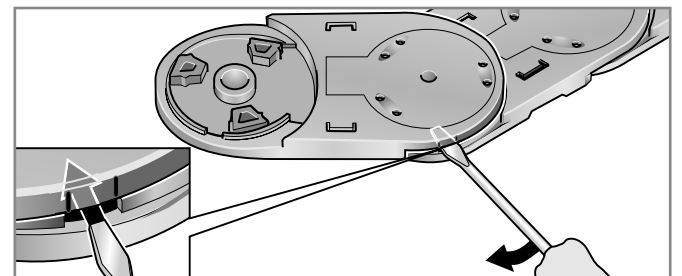

Step 3

Cable drag chain systems

PowerLine

MP 32.2

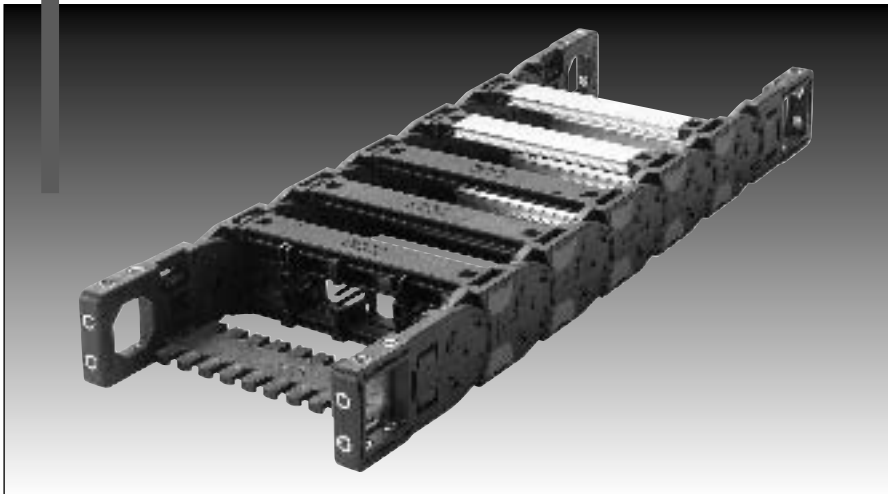



MP 32.2 - PowerLine 2nd generation

Order variants

Style (order code)						
Configuration (order code) *= standard						
Radius (order code) <small>The radii can be combined with any internal width</small>						
in inch						
Internal width (order code)						
in inch						
Outside width (order code)						
in inch						
MP 32.2 045	2.80	1.77	045			
MP 32.2 062	3.46	2.44	062			
MP 32.2 071	3.82	2.80	071			
MP 32.2 084	4.33	3.31	084			
MP 32.2 096	4.80	3.78	096			
MP 32.2 107	5.24	4.21	107			
MP 32.2 121	5.79	4.76	121			
MP 32.2 133	6.26	5.24	133			
MP 32.2 144	6.69	5.67	144			
MP 32.2 146	6.77	5.75	146			
MP 32.2 158	7.24	6.22	158			
MP 32.2 171	7.76	6.73	171			
MP 32.2 182	8.19	7.17	182			
MP 32.2 196	8.74	7.72	196			
MP 32.2 220	9.69	8.66	220			
MP 32.2 246	10.71	9.69	246			
MP 32.2 296	12.68	11.65	296			
MP 32.2 346	14.65	13.62	346			
MP 32.2 396	16.61	15.59	396	3.15	080	
MP 32.2 446	18.58	17.56	446	3.94	100	0
MP 32.2 496	20.55	19.53	496	4.72	120	2*
MP 32.2 546	22.52	21.50	546	5.91	150	4
MP 32.2 xxx	inside	>1.77	Alu	7.87	200	6
	+ 1.02	-23.62		9.84	250	9
						0
						2*
						4
						6
						9

Configuration:

- 0 PA crossbar every link; w/bias
- 2* PA crossbar EOL; w/bias
- 4 AL crossbar every link; w/bias
- 6 AL crossbar EOL; w/bias
- 9 Custom version

Style:

- 0 Standard (PA/black)
- 5 Polypropylene (PP/blue)
- 7 ESD (PA/light gray)
- 9 Custom version

Sample order:

0322 045 080 0000

Internal width = 1.77 in (45 mm)
 Radius = 3.15 in (80 mm)
 Configuration = 0
 Style = 0

Ideal operating conditions:

- Extreme accelerations
- Extreme speeds
- Very high additional loads
- Both sides must be opened
- Long travel distances
- Extreme self-supporting lengths









Alternative chain type:

- MP 32.3 closed series
- MP 35 for easy applications, opens toward inner bend
- MP 32 greater unsupported lengths

Order-Number:

Features



-  Chain bracket, can be fastened on three sides
-  Side links with CLICK lock for easy opening
-  Crossbar strain relief can be integrated into chain bracket
-  Foldable shelf system for reliable cable guidance
-  ESD cable drag chains for use in areas at risk of explosion
-  Crossbar/cover can be removed from inside and outside flexure curve
-  Radii with medium bias (R) for all applications
-  C-profile rail can be integrated into chain bracket
-  ESD cable drag chains for use in areas of electrostatic discharge

Technical data

Chain link dimensions (inch) (mm)

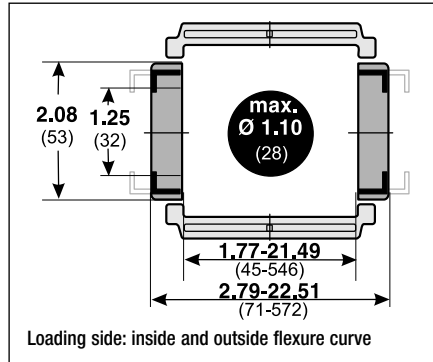

Material characteristics standard (PA/black)

Operating temperature: -22 to 248° F
 Gliding friction factor: 0.30
 Static friction factor: 0.45
 Fire classification: Based on UL94 HB

Other material properties on request

Technical specifications

Travel distance, gliding, L_g : 328.08 ft
 Travel distance, self-supporting, L_s : see diagram
 Travel distance, vertical, hanging, L_{vs} : 196.85 ft
 Travel distance, vertical, upright, L_{vs} : 16.40 ft
 Rotated 90°, self-supporting, L_{90r} : 3.28 ft
 Speed, gliding, V_g : 16.40 ft/s
 Speed, self-supporting, V_r : 65.62 ft/s
 Acceleration, gliding, a_g : 82.02 ft/s²
 Acceleration, self-supporting, a_s : 98.43 ft/s²

Self-supporting length

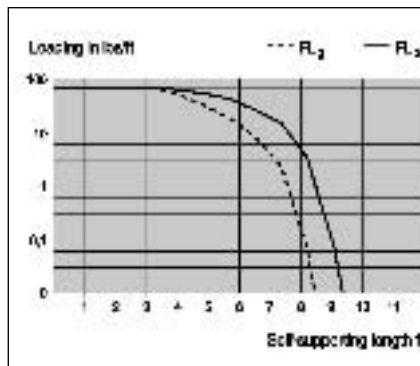
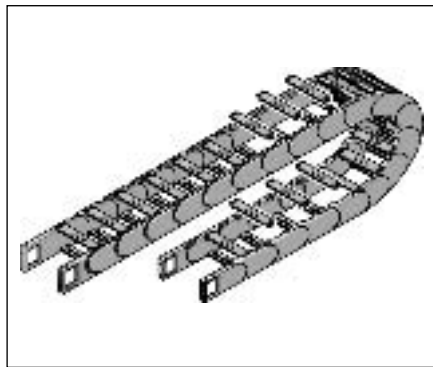

FL₁:
 Ideal installation situation for high stresses at the limit of the max. travel parameters. In this range the chain upper run is still biased, straight or has a max. sag of 0.39 – 1.97 in (10 – 50 mm) depending on the type of chain.

FL₂:
 Satisfactory installation position for many applications working in the lower to middle range of the max. travel parameters. Depending on the chain type, the sag of the chain upper run is >0.39 – 1.97 in (>10 – 50 mm) but certainly less than the max. sag.

If the sag is greater than FL₂, the arrangement is unsuitable and should be avoided. Please choose a more stable Murrplastik cable drag chain.

Determining the chain length

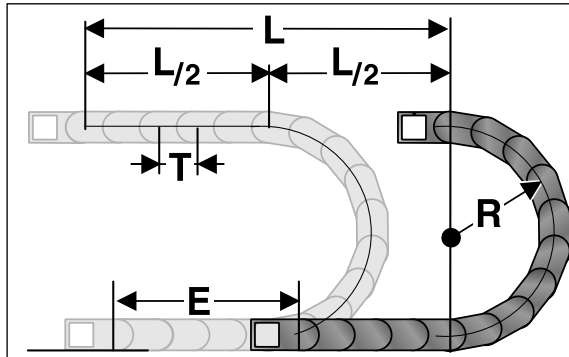

L = Travel distance
 R = Radius
 T = Pitch
 E = Distance between entry point and middle of travel distance

Determining the chain length

$$\text{Length} = \frac{L}{2} + \pi \times R + E$$

$$\approx 1 \text{ ft(m) chain} = 5(16) \text{ links each } 2.54 \text{ in (64,5 mm)}$$

The fixed point of the cable drag chain should be connected in the middle of the travel distance. This arrangement gives the shortest connection between the fixed point and the moving point and thus the most efficient chain length.

Installation dimensions (in inch)

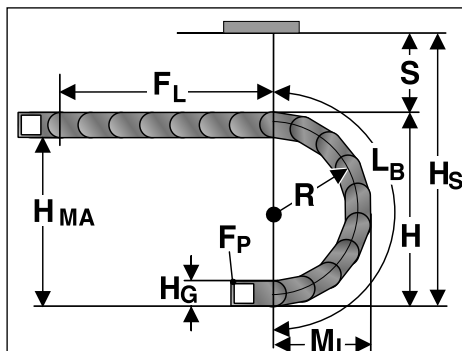

Radius R	3.15	3.94	4.72	5.91	7.87	9.84
Outside height of chain link (H_o)	2.09	2.09	2.09	2.09	2.09	2.09
Height of bend (H)	9.17	10.75	12.32	14.69	18.62	22.56
Height of moving end connection (H_{MA})	7.09	8.66	10.24	12.60	16.54	20.47
Safety margin (S)	1.18	1.18	1.18	1.18	1.18	1.18
Installation height (H_s)	10.36	11.93	13.50	15.87	19.80	23.74
Arc projection (M_L)	7.13	7.91	8.70	9.88	11.85	13.82
Bend length (L_b)	16.93	19.41	21.89	25.59	31.77	37.95



MP 32.2 - PowerLine 2nd generation

Chain bracket

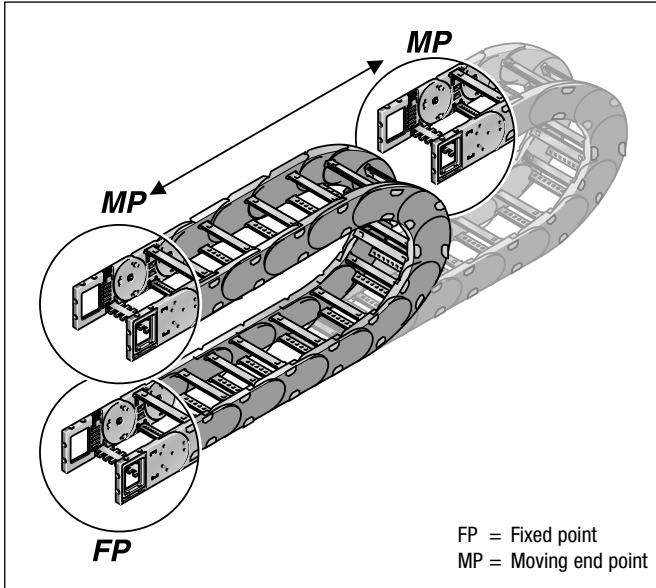

Flexible chain bracket

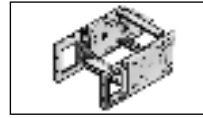

Flexible

Flexible chain bracket

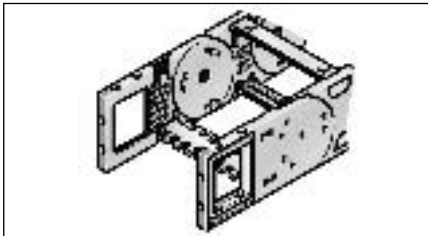

KA 32...

Type	Order no.	Version	Pack qty.
KA 32-FB	0321000054	with bushing	1
KA 32-FG	0321000055	with thread	1

This chain bracket offers universal connection options (top, bottom and front) and is attached to the ends of the chain like a side link. This allows the chain to move right up to the bracket. Each chain requires one male and one female bracket. M5 screws are used to secure the brackets in place. Extrusion-coated metal bushings with either a through-hole (-FB) or a threaded hole (-FG) ensure the permanent, high-strength transmission of even extreme forces onto the cable drag chain.

Flexible chain bracket

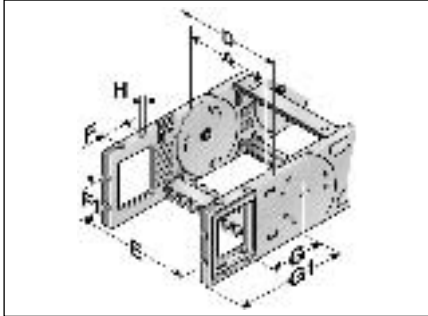

Flexible with through-hole (KA 32-FB)

Type	A inch	D inch	E inch	F inch	F1 inch	G inch	G1 inch	H Ø inch
KA 32-FB	1.77	2.80	2.32	0.89	0.87	2.28	3.66	0.22
KA 32-FB	2.44	3.46	2.99	0.89	0.87	2.28	3.66	0.22
KA 32-FB	2.80	3.82	3.35	0.89	0.87	2.28	3.66	0.22
KA 32-FB	3.31	4.33	3.86	0.89	0.87	2.28	3.66	0.22
KA 32-FB	3.78	4.80	4.33	0.89	0.87	2.28	3.66	0.22
KA 32-FB	4.21	5.24	4.76	0.89	0.87	2.28	3.66	0.22
KA 32-FB	4.76	5.79	5.31	0.89	0.87	2.28	3.66	0.22
KA 32-FB	5.24	6.26	5.79	0.89	0.87	2.28	3.66	0.22
KA 32-FB	5.67	6.69	6.22	0.89	0.87	2.28	3.66	0.22
KA 32-FB	5.75	6.77	6.30	0.89	0.87	2.28	3.66	0.22
KA 32-FB	6.22	7.24	6.77	0.89	0.87	2.28	3.66	0.22
KA 32-FB	6.73	7.76	7.28	0.89	0.87	2.28	3.66	0.22
KA 32-FB	7.17	8.19	7.72	0.89	0.87	2.28	3.66	0.22
KA 32-FB	7.72	8.74	8.27	0.89	0.87	2.28	3.66	0.22
KA 32-FB	8.66	9.69	9.21	0.89	0.87	2.28	3.66	0.22
KA 32-FB	9.69	10.71	10.24	0.89	0.87	2.28	3.66	0.22
KA 32-FB	11.65	12.68	12.20	0.89	0.87	2.28	3.66	0.22
KA 32-FB	13.62	14.65	14.17	0.89	0.87	2.28	3.66	0.22
KA 32-FB	15.59	16.61	16.14	0.89	0.87	2.28	3.66	0.22
KA 32-FB	17.56	18.58	18.11	0.89	0.87	2.28	3.66	0.22
KA 32-FB	19.53	20.55	20.08	0.89	0.87	2.28	3.66	0.22
KA 32-FB	21.50	22.52	22.05	0.89	0.87	2.28	3.66	0.22

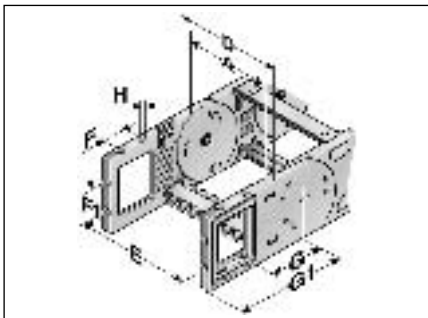

Flexible with with threaded bushing (KA 32-FG)

Type	A inch	D inch	E inch	F inch	F1 inch	G inch	G1 inch	H
KA 32-FG	1.77	2.80	2.32	0.89	0.87	2.28	3.66	M5
KA 32-FG	2.44	3.46	2.99	0.89	0.87	2.28	3.66	M5
KA 32-FG	2.80	3.82	3.35	0.89	0.87	2.28	3.66	M5
KA 32-FG	3.31	4.33	3.86	0.89	0.87	2.28	3.66	M5
KA 32-FG	3.78	4.80	4.33	0.89	0.87	2.28	3.66	M5
KA 32-FG	4.21	5.24	4.76	0.89	0.87	2.28	3.66	M5
KA 32-FG	4.76	5.79	5.31	0.89	0.87	2.28	3.66	M5
KA 32-FG	5.24	6.26	5.79	0.89	0.87	2.28	3.66	M5
KA 32-FG	5.67	6.69	6.22	0.89	0.87	2.28	3.66	M5
KA 32-FG	5.75	6.77	6.30	0.89	0.87	2.28	3.66	M5
KA 32-FG	6.22	7.24	6.77	0.89	0.87	2.28	3.66	M5
KA 32-FG	6.73	7.76	7.28	0.89	0.87	2.28	3.66	M5
KA 32-FG	7.17	8.19	7.72	0.89	0.87	2.28	3.66	M5
KA 32-FG	7.72	8.74	8.27	0.89	0.87	2.28	3.66	M5
KA 32-FG	8.66	9.69	9.21	0.89	0.87	2.28	3.66	M5
KA 32-FG	9.69	10.71	10.24	0.89	0.87	2.28	3.66	M5
KA 32-FG	11.65	12.68	12.20	0.89	0.87	2.28	3.66	M5
KA 32-FG	13.62	14.65	14.17	0.89	0.87	2.28	3.66	M5
KA 32-FG	15.59	16.61	16.14	0.89	0.87	2.28	3.66	M5
KA 32-FG	17.56	18.58	18.11	0.89	0.87	2.28	3.66	M5
KA 32-FG	19.53	20.55	20.08	0.89	0.87	2.28	3.66	M5
KA 32-FG	21.50	22.52	22.05	0.89	0.87	2.28	3.66	M5



Assembly instruction flexible chain bracket

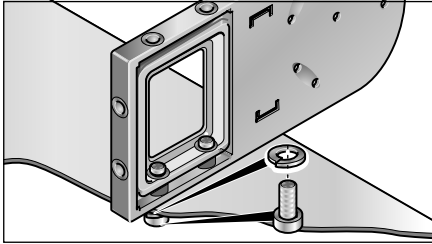

Chain bracket with threaded bushing

Brass bushings guarantee long-lasting fastening without cold flow in the plastic.

Version KA-FB:

Integrated through-hole fastened down using screw and nut.

Version KA-FG:

Built-in threads allow for quick and easy on-site mounting, since a screw, including a retaining washer where necessary, is sufficient.

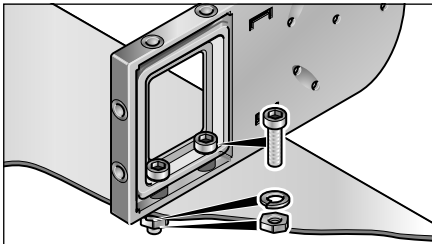

Chain bracket with bushing

Separator

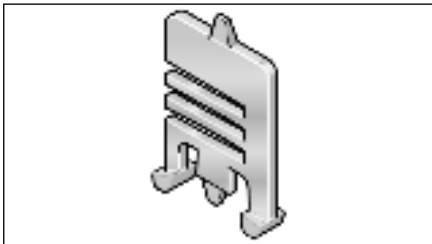

Separator

Type	Order no.	Designation	Pitch inch	Pack qty.
TR 1.26	032200009200	Separator	0.22	1

We recommend that separators be used if multiple round cables or conduits with differing diameters are to be installed. An offset configuration of the separators is advisable.

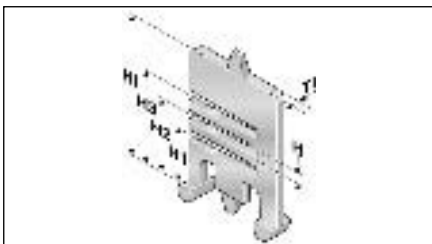

Separator

Type	T1 inch	H inch	H1 inch	H2 inch	H3 inch	H1 inch
TR 32.1	0.14	0.16	0.33	0.57	0.81	1.26

Shelving system

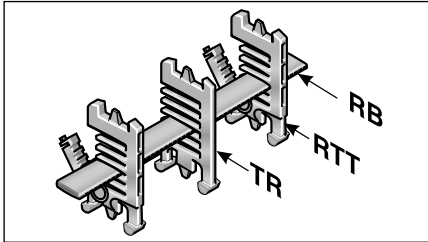

Shelving system

Type	Order no.	Designation	Width inch	Pitch inch	Pack qty.
RB 028-5	100000002800	RB 028-5 Shelf	1.10	0.22	1
RB 056-5	100000005600	RB 056-5 Shelf	2.20	0.22	1
RB 084-5	100000008400	RB 084-5 Shelf	3.31	0.22	1
RB 112-5	100000011200	RB 112-5 Shelf	4.41	0.22	1
RB 140-5	100000014000	RB 140-5 Shelf	5.51	0.22	1
RB 168-5	100000016800	RB 168-5 Shelf	6.61	0.22	1
RB 196-5	100000019600	RB 196-5 Shelf	7.72	0.22	1
RTT 32	100090322000	RTT 32 Shelf support, divisible		0.22	1

In connection with at least two shelf supports (RTT) the shelf becomes a shelving system. The additional levels prevent cables from criss-crossing and therefore destroying each other, while also avoiding excessive friction. Pre-assembly is not necessary as the shelving system and cabling can be assembled quickly and easily on site.

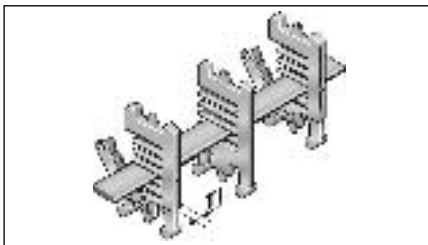

Shelving system

Type	TI inch
RTT 32	0.28

Crossbar connector

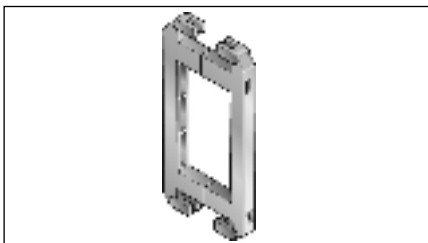

Crossbar connector

Type	Order no.	Designation	Pack qty.
RSV 32	032000009600	RSV 32 Crossbar connector	1
RSV 32 Alu	032000009800	RSV 32 Crossbar connector for aluminum crossbridges	1

For frame bridges wider than 9.69 in (246 mm), we recommend the use of crossbar connectors. These prevent deformation to the frame bridge under large amounts of additional weight of the chain assembly.

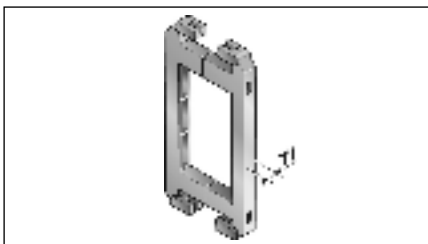

Type	TI inch
RSV 32	0.30
RSV 32 Alu	0.30



Crossbar strain relief plate RS-ZL



Crossbar strain relief plate RS-ZL

Type	Order no.	For internal width inch	Pack qty.
RS-ZL 045-5	052004500010	1.77	1
RS-ZL 062-5	052006200010	2.44	1
RS-ZL 071-5	052007100010	2.80	1
RS-ZL 084-5	052008400010	3.31	1
RS-ZL 096-5	052009600010	3.78	1
RS-ZL 107-5	052010700010	4.21	1
RS-ZL 121-5	052012100010	4.76	1
RS-ZL 133-5	052013300010	5.24	1
RS-ZL 5.67/5.75-5	052014400010	5.67/5.75	1
RS-ZL 158-5	052015800010	6.22	1
RS-ZL 171-5	052017100010	6.73	1
RS-ZL 182-5	052018200010	7.17	1
RS-ZL 196-5	052019600010	7.72	1
RS-ZL 8.66-5	052022000010	8.66	1
RS-ZL 246-5	052024600010	9.69	1

Fixed integrated frame bridge strain relief plates in the chain brackets. Tailored to all frame bridge widths up to 9.69 in (246 mm). May be assembled on the inside and outside flexure curves at both chain endings.

Strain relief type BAK

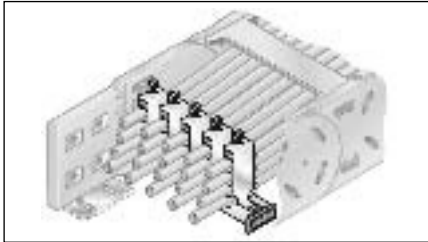

Strain relief with hooped clamp

Type	Order no.	Designation	Ø inch	Number of seats	Pack qty.
C-rail	81661610	C-profile rail			1
BA 12	81661036	BA 12 Hooped clamp	0.35–0.47	1	1
BAK 14	81661002	BAK 14 Hooped clamp	0.24–0.55	1	1
BAK 18	81661004	BAK 18 Hooped clamp	0.55–0.71	1	1
BAK 22	81661006	BAK 22 Hooped clamp	0.71–0.87	1	1
BAK 26	81661008	BAK 26 Hooped clamp	0.87–1.02	1	1
BAK 30	81661010	BAK 30 Hooped clamp	1.02–1.18	1	1
BAK 34	81661000	BAK 34 Hooped clamp	1.18–1.34	1	1
BAK 38	81661044	BAK 38 Hooped clamp	1.34–1.50	1	1
BAK 42	81661032	BAK 42 Hooped clamp	1.50–1.65	1	1
BAK 46	81661050	BAK 46 Hooped clamp	1.65–1.81	1	1
BA 12/2	81661038	BA 12/2 Hooped clamp	0.35–0.47	2	1
BAK 14/2	81661012	BAK 14/2 Hooped clamp	0.39–0.55	2	1
BAK 18/2	81661014	BAK 18/2 Hooped clamp	0.55–0.71	2	1
BAK 22/2	81661016	BAK 22/2 Hooped clamp	0.71–0.87	2	1
BAK 26/2	81661018	BAK 26/2 Hooped clamp	0.87–1.02	2	1
BAK 30/2	81661048	BAK 30/2 Hooped clamp	1.02–1.18	2	1
BAK 34/2	81661044	BAK 34/2 Hooped clamp	1.18–1.34	2	1
BAK 38/2	81661046	BAK 38/2 Hooped clamp	1.34–1.50	2	1
BAK 42/2	81661034	BAK 42/2 Hooped clamp	1.50–1.65	2	1
BAK 12/3	81661020	BAK 12/3 Hooped clamp	0.35–0.47	3	1
BAK 14/3	81661022	BAK 14/3 Hooped clamp	0.47–0.55	3	1
BAK 16/3	81661024	BAK 16/3 Hooped clamp	0.55–0.63	3	1
BAK 18/3	81661026	BAK 18/3 Hooped clamp	0.63–0.71	3	1
BAK 20/3	81661028	BAK 20/3 Hooped clamp	0.71–0.79	3	1
BAK 22/3	81661030	BAK 22/3 Hooped clamp	0.79–0.87	3	1

Fixed integrated strain relief in the chain connections. Available in all widths (also individual widths for aluminum frame ridges). May be assembled on the inside and outside flexure curves at both chain endings. Chain content is secured through hooped clamps that are available in different sizes. Material: Galvanized steel.

When ordering please indicate the type of chain and internal width.



MP 32.2 - Accessories

Assembly Disassembly

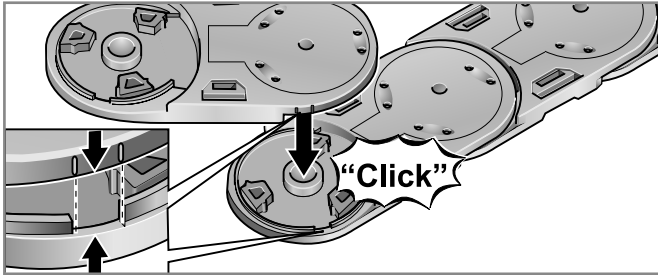

Step 1

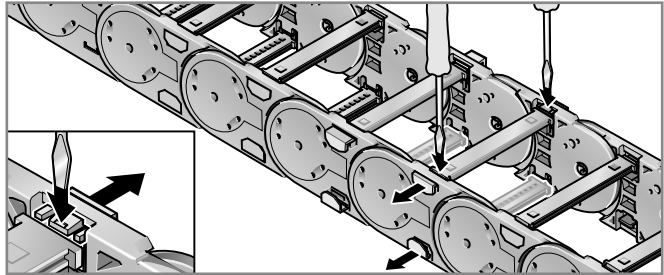

Step 1

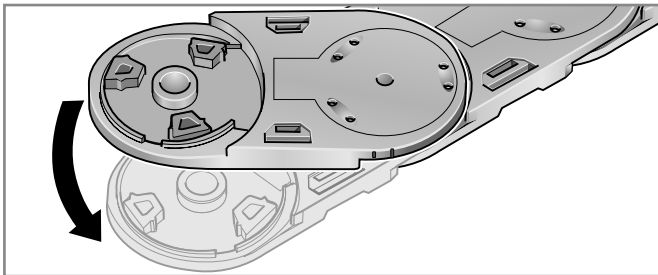

Step 2

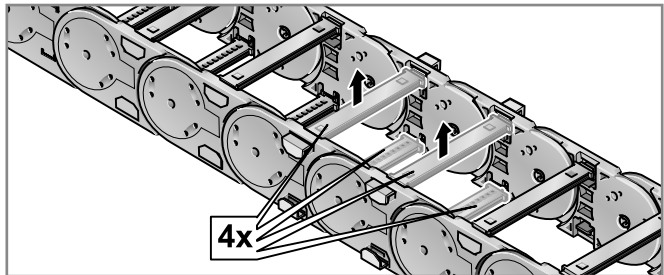

Step 2

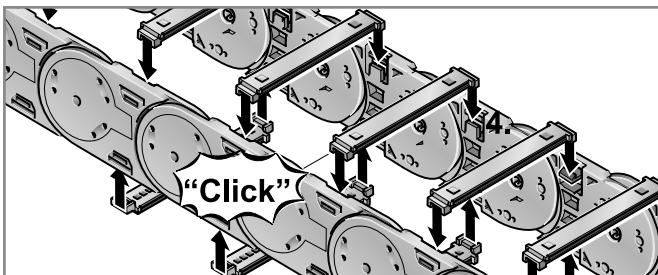

Step 3

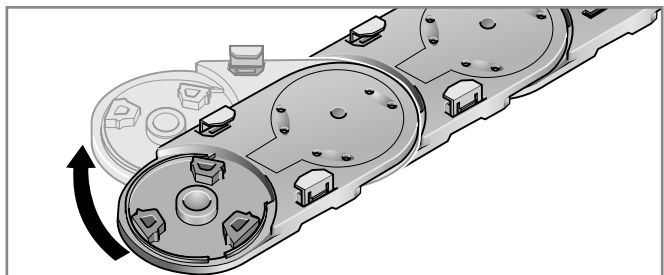

Step 3

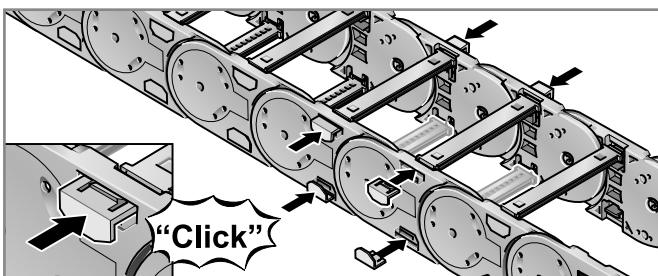

Step 4

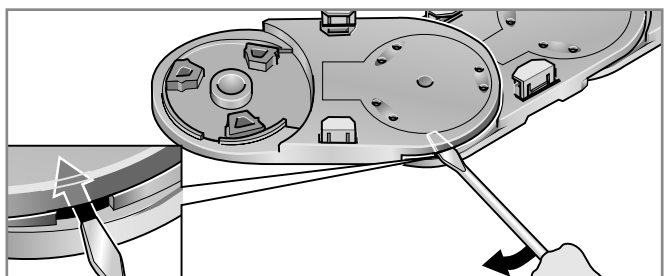

Step 4

Cable drag chain systems

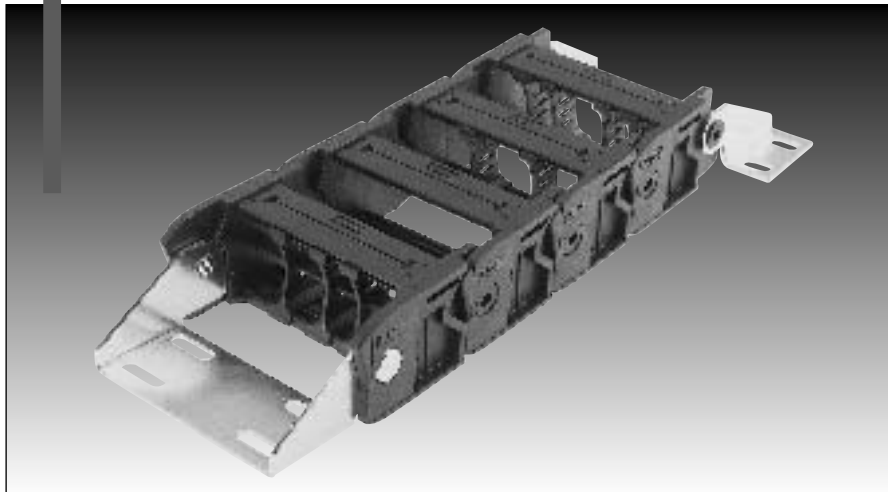

MultiLine

MP 35



MP 35 - MultiLine

Order variants

Style (order code)							
Configuration (order code)							
Radius (order code)		The radii can be combined with any internal width					
in inch							
Internal width (order code)							
in inch							
Outside width							
in inch							
MP35 062	3.23	2.44	062	2.76	070	0	0
MP35 086	4.17	3.39	086	3.94	100	1	9
MP35 102	4.80	4.02	102	5.91	150		
MP35 125	5.71	4.92	125	7.87	200		
MP35 150	6.69	5.91	150	11.81	300		

Order-Number:	0350			0			0
----------------------	-------------	--	--	----------	--	--	----------

Configuration:

0 PA crossbar every link; w/bias
 1 PA crossbar every link; w/o bias

Style:

0 Standard (PA/black)
 9 Custom version

Sample order:

0350 062 070 0000

Internal width = 2.44 in (62 mm)
 Radius = 2.76 in (70 mm)
 Configuration = 0
 Style = 0

Ideal operating conditions:







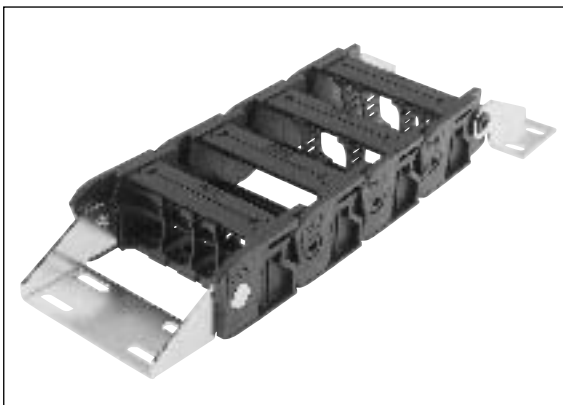

- Compact dimensions with opening cover in inside bend
- Quiet operation
- High stability
- Flexible internal separation
- Rotated 90° unsupported
- Version with bias (RV) for greater self-supporting length
- Version with bias (RV) for gliding arrangement

Alternative chain type:

- MP 36 G closed series
- MP 32 can be opened on both sides
- MP 32 variable widths
- MP 32 greater stresses
- MP 32 flange connection (KA-F)
- MP 32 reverse radii

Features



-  Chain bracket with variably positionable metal angle
-  Reverse radius combinations
-  Integrable separator for cable separation
-  Plug-in shelf system for reliable cable guidance
-  Chain bracket/metal bracket
-  Radii with or without bias (RV/RK)
-  H-shelf for simple cable separation in the chain compartment
-  Crossbars can be removed on one side
-  Strain relief plate ZL

Technical data

Chain link dimensions (inch) (mm)

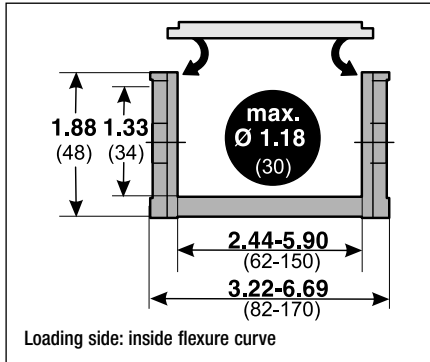

Material characteristics standard (PA/black)

Operating temperature: -22 to 248° F
 Gliding friction factor: 0.30
 Static friction factor: 0.45
 Fire classification: Based on UL94 HB

Other material properties on request

Technical specifications

Travel distance, gliding, L_g : 262.47 ft
 Travel distance, self-supporting, L_s : see diagram
 Travel distance, vertical, hanging, L_{vh} : 131.23 ft
 Travel distance, vertical, upright, L_{vu} : 9.84 ft
 Rotated 90°, self-supporting, L_{90r} : 3.28 ft
 Speed, gliding, V_g : 9.84 ft/s
 Speed, self-supporting, V_s : 32.81 ft/s
 Acceleration, gliding, a_g : 49.21 ft/s²
 Acceleration, self-supporting, a_s : 65.62 ft/s²

Self-supporting length

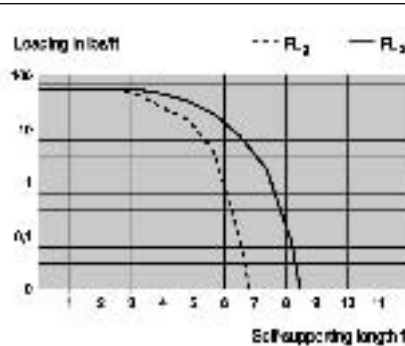
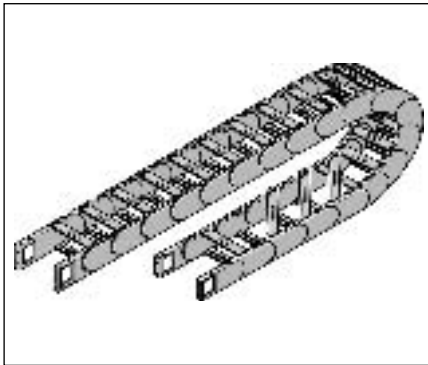

FL₁:
 Ideal installation situation for high stresses at the limit of the max. travel parameters. In this range the chain upper run is still biased, straight or has a max. sag of 0.39 – 1.97 in (10 – 50 mm) depending on the type of chain.

FL₂:
 Satisfactory installation position for many applications working in the lower to middle range of the max. travel parameters. Depending on the chain type, the sag of the chain upper run is >0.39 – 1.97 in (>10 – 50 mm) but certainly less than the max. sag.

If the sag is greater than FL₂, the arrangement is unsuitable and should be avoided. Please choose a more stable Murrplastik cable drag chain.

Determining the chain length

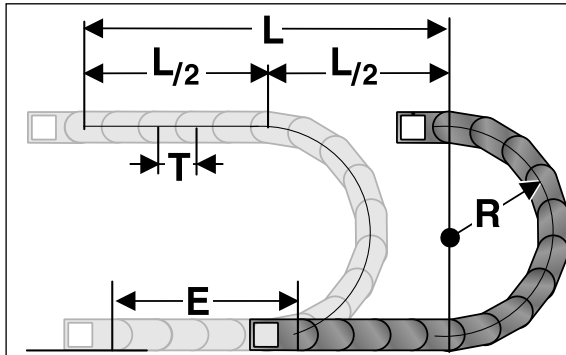

Determining the chain length

$$\text{Length} = \frac{L}{2} + \pi \times R + 2 \times T + E$$

≈ 1 ft(m) chain = 6(17) links each 2.28 in (58 mm)

The fixed point of the cable drag chain should be connected in the middle of the travel distance. This arrangement gives the shortest connection between the fixed point and the moving point and thus the most efficient chain length.

Installation dimensions (in inch)

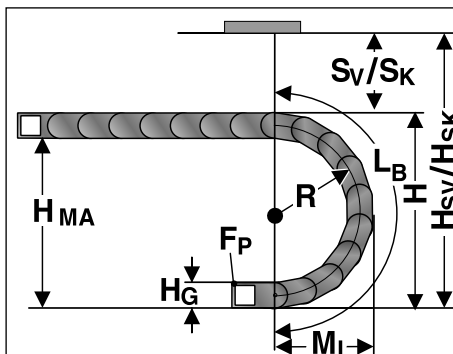

Radius R	2.76	3.94	5.91	7.87	11.81
Outside height of chain link (H_o)	1.89	1.89	1.89	1.89	1.89
Height of bend (H)	7.40	9.76	13.70	17.64	25.51
Height of moving end connection (H_{ma})	5.51	7.87	11.81	15.75	23.62
Safety margin with bias (S_v)	1.57	1.57	1.57	1.57	1.57
Installation height with bias (H_{sv})	8.98	11.34	15.28	19.21	27.09
Safety margin without bias (S_k)	0.59	0.59	0.59	0.59	0.59
Installation height without bias (H_{sk})	7.99	10.35	14.29	18.23	26.10
Arc projection (M_l)	5.98	7.17	9.13	11.10	15.04
Bend length (L_b)	13.90	17.60	23.78	29.96	42.32



Chain bracket

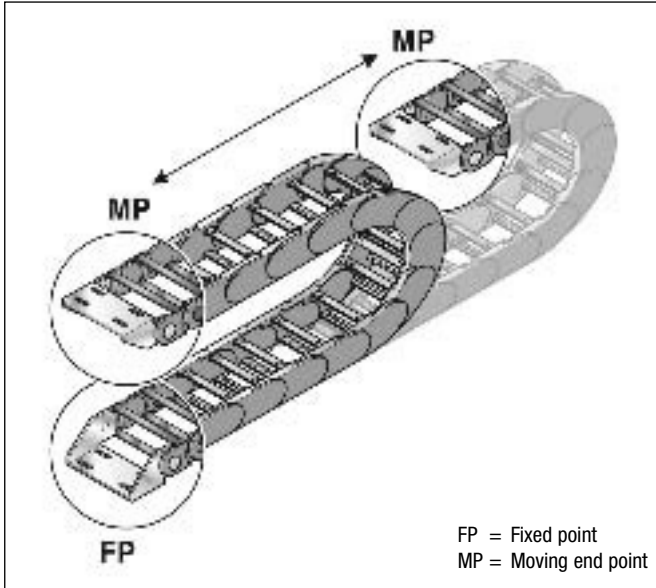

Chain bracket U-part

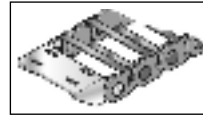

Top

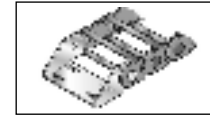

Bottom

Chain bracket angle



Bottom/Outside

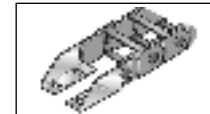

Bottom/Inside

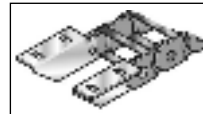

Top/Outside

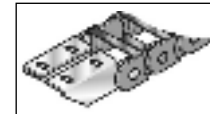

Top/Inside

Chain bracket U-part

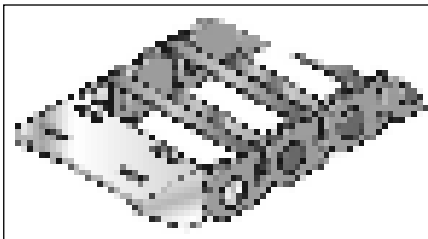

KA 35062–KA 35150

Type	Order no.	Material	Pack qty.
KA 35062 Female end	03500007000	Sheet steel	1
KA 35062 Male end	03500007100	Sheet steel	1
KA 35086 Female end	03500007200	Sheet steel	1
KA 35086 Male end	03500007300	Sheet steel	1
KA 35102 Female end	03500007400	Sheet steel	1
KA 35102 Male end	03500007500	Sheet steel	1
KA 35125 Female end	03500007600	Sheet steel	1
KA 35125 Male end	03500007700	Sheet steel	1
KA 35150 Female end	03500007800	Sheet steel	1
KA 35150 Male end	03500007900	Sheet steel	1
KA 35062 Female end	03500008000	Stainless steel 1.4301	1
KA 35062 Male end	03500008100	Stainless steel 1.4301	1
KA 35086 Female end	03500008200	Stainless steel 1.4301	1
KA 35086 Male end	03500008300	Stainless steel 1.4301	1
KA 35102 Female end	03500008400	Stainless steel 1.4301	1
KA 35102 Male end	03500008500	Stainless steel 1.4301	1
KA 35125 Female end	03500008600	Stainless steel 1.4301	1
KA 35125 Male end	03500008700	Stainless steel 1.4301	1
KA 35150 Female end	03500008800	Stainless steel 1.4301	1
KA 35150 Male end	03500008900	Stainless steel 1.4301	1

The metal connection (U-shaped part) is precisely adjusted to the respective chain width. It only needs to be snapped in the chain link. Please order one male and one female end bracket for each chain. The brackets should be fastened with M6 screws.

Chain bracket angle

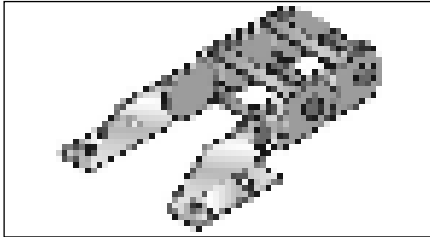

KA 3508–KA 3509

Type	Order no.	Material	Pack qty.
KA 3508 Female end	0350000054	Sheet steel	1
KA 3508 Male end	0350000055	Sheet steel	1
KA 3509 Female end	0350000056	Stainless steel 1.4301	1
KA 3509 Male end	0350000057	Stainless steel 1.4301	1

Please order one male and one female end bracket for each chain.

Chain bracket U-part

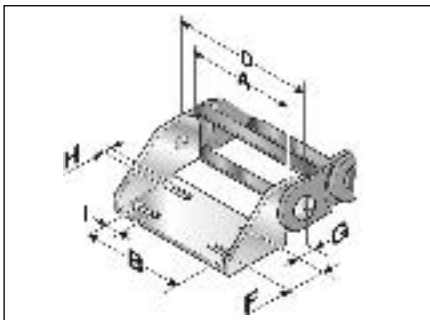

KA 35062-150

Type	A inch	B inch	D inch	F inch	G inch	H Ø inch	I inch
KA 35062	2.44	2.11	3.23	0.98	0.79	0.28	0.59
KA 35086	3.39	3.05	4.17	0.98	0.79	0.28	0.59
KA 35102	4.02	3.68	4.80	0.98	0.79	0.28	0.59
KA 35125	4.92	4.59	5.71	0.98	0.79	0.28	0.59
KA 35150	5.91	5.59	6.69	0.98	0.79	0.28	0.59

Chain bracket angle

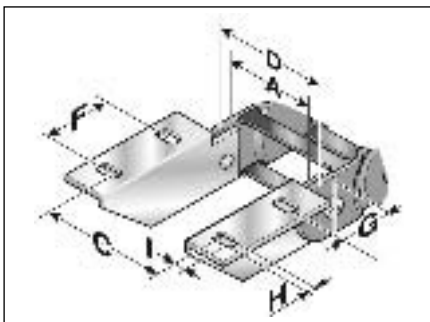

Angle exterior

Type	A inch	C inch	D inch	F inch	G inch	H Ø inch	I inch
KA 3508/09 Female end	2.44	3.54	3.23	0.98	0.79	0.28	0.31
KA 3508/09 Male end	2.44	3.96	3.23	0.98	0.79	0.28	0.31
KA 3508/09 Female end	3.39	4.49	4.17	0.98	0.79	0.28	0.31
KA 3508/09 Male end	3.39	4.90	4.17	0.98	0.79	0.28	0.31
KA 3508/09 Female end	4.02	5.12	4.80	0.98	0.79	0.28	0.31
KA 3508/09 Male end	4.02	5.53	4.80	0.98	0.79	0.28	0.31
KA 3508/09 Female end	4.92	6.02	5.71	0.98	0.79	0.28	0.31
KA 3508/09 Male end	4.92	6.44	5.71	0.98	0.79	0.28	0.31
KA 3508/09 Female end	5.91	7.01	6.69	0.98	0.79	0.28	0.31
KA 3508/09 Male end	5.91	7.42	6.69	0.98	0.79	0.28	0.31

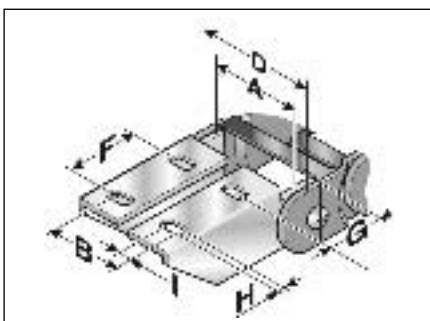

Angle interior

Type	A inch	B inch	D inch	F inch	G inch	H Ø inch	I inch
KA 3508/09 Female end	2.44	2.17	3.23	0.98	0.79	0.28	0.31
KA 3508/09 Male end	2.44	1.97	3.23	0.98	0.79	0.28	0.31
KA 3508/09 Female end	3.39	3.11	4.17	0.98	0.79	0.28	0.31
KA 3508/09 Male end	3.39	2.91	4.17	0.98	0.79	0.28	0.31
KA 3508/09 Female end	4.02	3.74	4.80	0.98	0.79	0.28	0.31
KA 3508/09 Male end	4.02	3.54	4.80	0.98	0.79	0.28	0.31
KA 3508/09 Female end	4.92	4.65	5.71	0.98	0.79	0.28	0.31
KA 3508/09 Male end	4.92	4.45	5.71	0.98	0.79	0.28	0.31
KA 3508/09 Female end	5.91	5.63	6.69	0.98	0.79	0.28	0.31
KA 3508/09 Male end	5.91	5.43	6.69	0.98	0.79	0.28	0.31



Separator



Separator

Type	Order no.	Designation	Pitch inch	Pack qty.
TR 35	035000009200	Separator	0.12 lockable	1

We recommend that separators be used if multiple round cables or conduits with differing diameters are to be installed. An offset configuration of the separators is advisable.

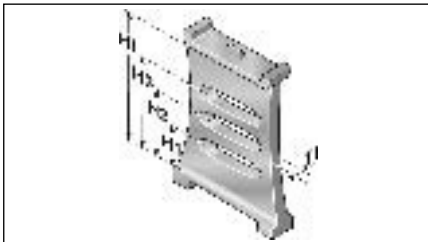

Separator

Type	T1 inch	H1 inch	H2 inch	H3 inch	HI inch	H inch
TR 35	0.08	0.43	0.67	0.90	1.33	0.10

H-shaped shelf unit

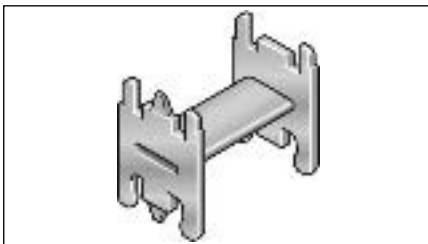

H-shaped shelf unit

Type	Order no.	Designation	Pitch inch	Pack qty.
RE 35/33	100000353310	RE 35/33 H-shaped shelf unit	0.22	1
RE 35/48	100000354810	RE 35/48 H-shaped shelf unit	0.22	1
RE 35/57	100000355710	RE 35/57 H-shaped shelf unit	0.22	1

Insert to obtain additional levels in pre-defined distances.

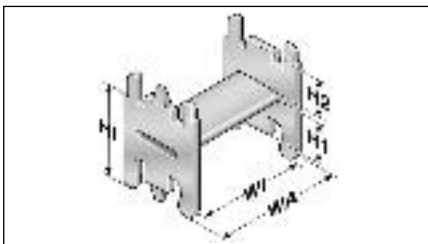

H-shaped shelf unit

Type	WA inch	WI inch	H1 inch	H2 inch	HI inch
RE 35/33	1.40	1.20	0.71	0.47	1.30
RE 35/48	1.99	1.79	0.71	0.47	1.30
RE 35/57	2.34	2.15	0.71	0.47	1.30

Shelving system

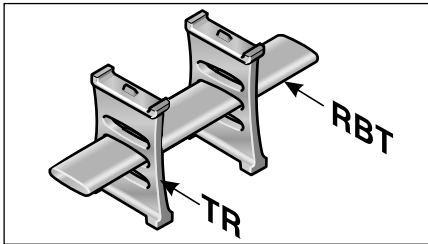

Shelving system

Type	Order no.	Designation	Width inch	Pitch inch	Pack qty.
RBT 062	100000006200	RBT 062 shelf	2.44	0.12	1
RBT 086	100000008600	RBT 086 shelf	3.39	0.12	1
RBT 101	100000010100	RBT 101 shelf	3.98	0.12	1
RBT 125	100000012500	RBT 125 shelf	4.92	0.12	1
RBT 150	100000015000	RBT 150 shelf	5.91	0.12	1

The shelf must be used with a minimum of two separators to create a shelving system. The additional levels prevent cables from criss-crossing and therefore destroying each other, while also avoiding excessive friction. The shelves are matched to the available chain widths.

Assembly

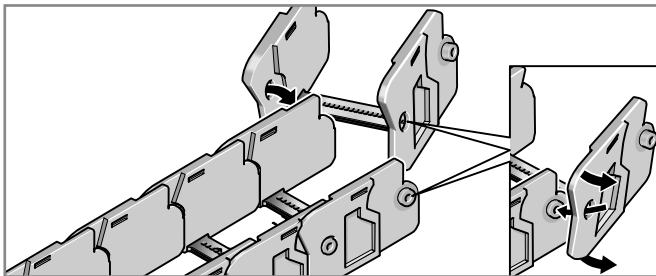

Step 1

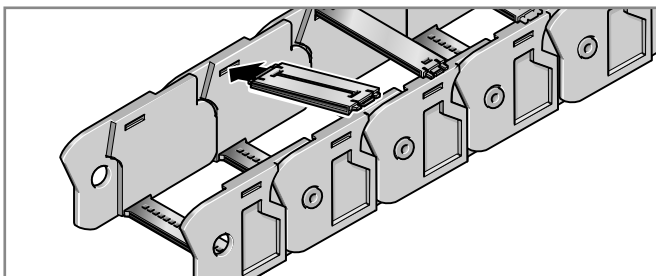

Step 2

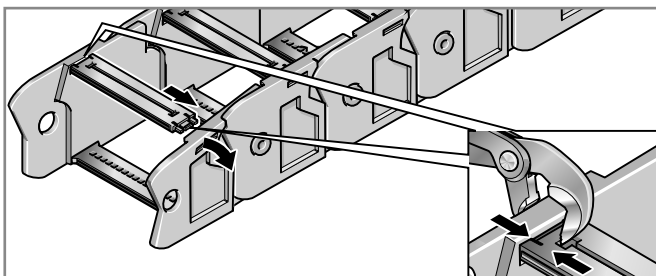

Step 3

Disassembly

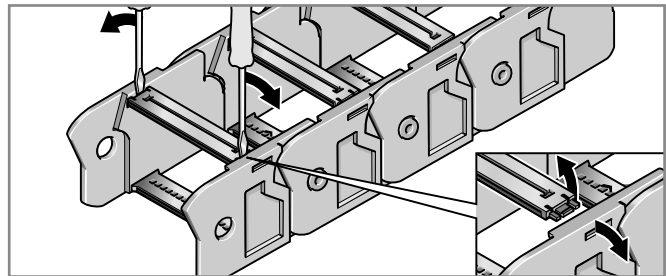

Step 1

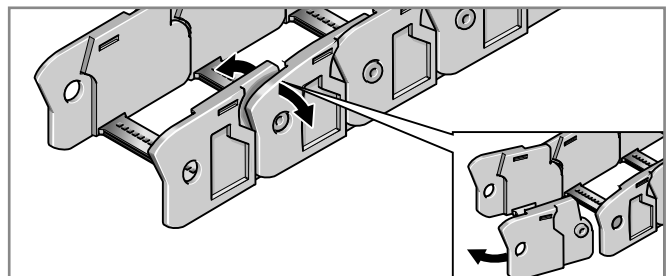

Step 2

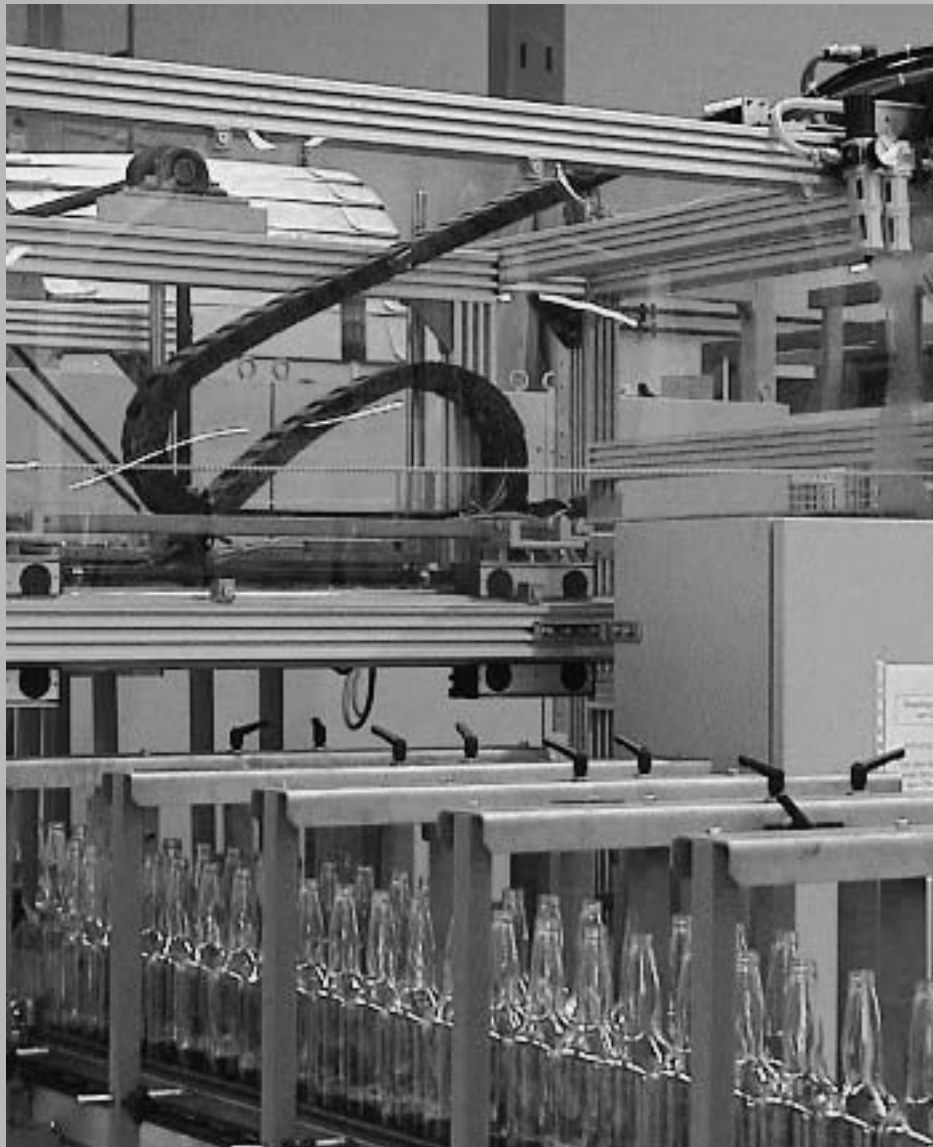

Cable drag chain systems

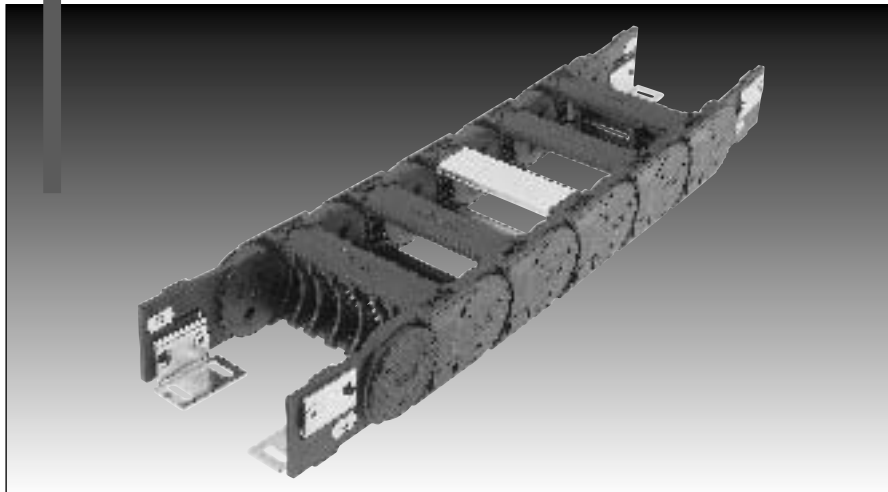

MultiLine

MP 44



MP 44 - MultiLine

Order variants

Style (order code)						
Configuration (order code) * = standard						
Radius (order code) <small>The radii can be combined with any internal width</small>						
in inch						
Internal width (order code)						
in inch						
Outside width in inch						
MP44 045	3.07	1.77	045			0*
MP44 062	3.74	2.44	062			1*
MP44 084	4.61	3.31	084			2
MP44 105	5.43	4.13	105	3.54	090	3
MP44 144	6.97	5.67	144	4.92	125	4
MP44 182	8.46	7.17	182	5.91	150	5
MP44 xxx	inside + 1.30	>118 -23.62	Alu	7.87	200	6
				9.84	250	7
						8
						9
						0
						9

Order-Number:

Configuration:

- 0* PA crossbar every link; w/bias
- 1* PA crossbar every link; w/o bias
- 2 PA crossbar EOL; w/bias
- 3 PA crossbar EOL; w/o bias
- 4 AL crossbar every link; w/bias
- 5 AL crossbar every link; w/o bias
- 6 AL crossbar EOL; w/bias
- 7 AL crossbar EOL; w/o bias
- 9 Custom version

Style:

- 0 Standard (PA/black)
- 9 Custom version

Sample order:

0440 045 090 0000

Internal width = 1.77 in (45 mm)
 Radius = 3.54 in (90 mm)
 Configuration = 0
 Style = 0

Ideal operating conditions:

- Opening cover in inside/outside bend
- Flexible internal separation
- Aluminum frame bridge in variable lengths
- Gliding arrangement
- Unsupported arrangement
- Quiet operation

Alternative chain type:

- MP 43 G closed series
- MP 41 greater stresses
- MP 41 flange connection (KA-F)
- MP 41 reverse radii

Features

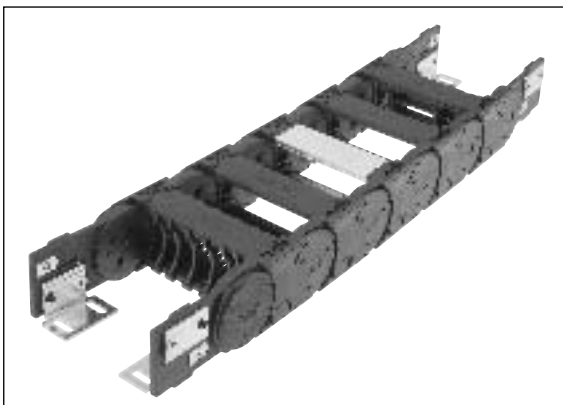

Chain bracket with variably positionable metal angle



Radii with or without bias (RV/RK)



Plug-in shelf system for reliable cable guidance



Crossbar/cover can be removed from inside and outside flexure curve



Aluminum frame bridges with integrated lock grid in variable lengths



Strain relief plate ZL

Technical data

Chain link dimensions (inch) (mm)

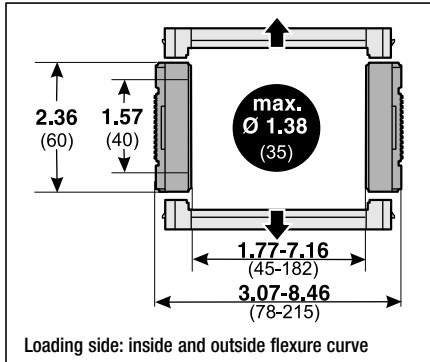

Material characteristics standard (PA/black)

Operating temperature: -22 to 248° F
 Gliding friction factor: 0.30
 Static friction factor: 0.45
 Fire classification: Based on UL94 HB

Other material properties on request

Technical specifications

Travel distance, gliding, L_g : 164.04 ft
 Travel distance, self-supporting, L_s : see diagram
 Travel distance, vertical, hanging, L_{vh} : 131.23 ft
 Travel distance, vertical, upright, L_{vu} : 9.84 ft
 Rotated 90°, self-supporting, L_{90r} : 3.28 ft
 Speed, gliding, V_g : 16.40 ft/s
 Speed, self-supporting, V_s : 49.21 ft/s
 Acceleration, gliding, a_g : 49.21 ft/s²
 Acceleration, self-supporting, a_s : 65.62 ft/s²

Self-supporting length

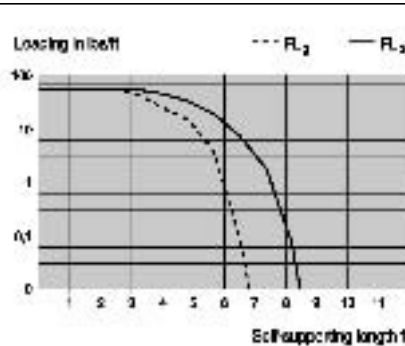
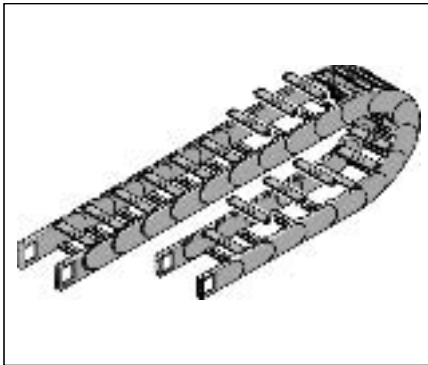

FL₂:
 Ideal installation situation for high stresses at the limit of the max. travel parameters. In this range the chain upper run is still biased, straight or has a max. sag of 0.39 – 1.97 in (10 – 50 mm) depending on the type of chain.

FL₃:
 Satisfactory installation position for many applications working in the lower to middle range of the max. travel parameters. Depending on the chain type, the sag of the chain upper run is >0.39 – 1.97 in (>10 – 50 mm) but certainly less than the max. sag.

If the sag is greater than FL₃, the arrangement is unsuitable and should be avoided. Please choose a more stable Murrplastik cable drag chain.

Determining the chain length

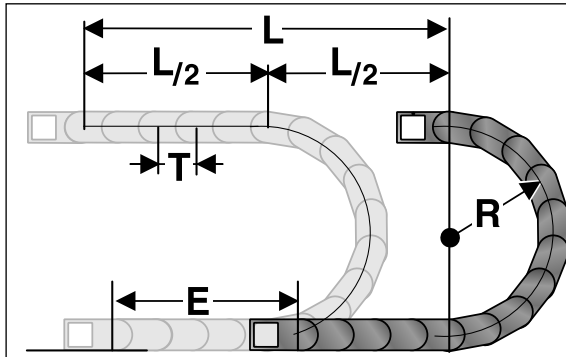

Determining the chain length

$$\text{Length} = \frac{L}{2} + \pi \times R + E$$

$$\approx 1 \text{ ft(m) chain} = 4(13) \text{ links each } 2.97 \text{ in (75,5 mm)}$$

The fixed point of the cable drag chain should be connected in the middle of the travel distance. This arrangement gives the shortest connection between the fixed point and the moving point and thus the most efficient chain length.

Installation dimensions (in inch)

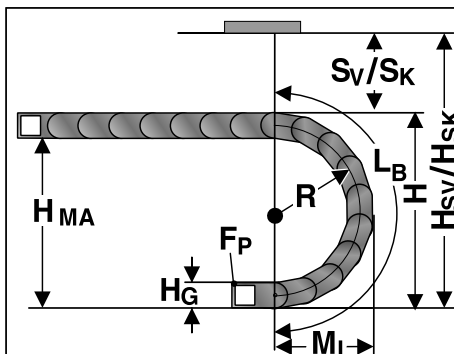

Radius R	3.54	4.92	5.91	7.78	9.84
Outside height of chain link (H_o)	2.36	2.36	2.36	2.36	2.36
Height of bend (H)	9.45	12.20	14.17	18.11	22.05
Height of moving end connection (H_{ma})	7.09	9.84	11.81	15.75	19.69
Safety margin with bias (S_v)	1.50	1.50	1.50	1.50	1.50
Installation height with bias (H_{sv})	10.94	13.70	15.67	19.61	23.54
Safety margin without bias (S_k)	0.51	0.51	0.51	0.51	0.51
Installation height without bias (H_{sk})	9.96	12.72	14.69	18.62	22.56
Arc projection (M_l)	7.72	9.06	10.08	12.05	14.02
Bend length (L_b)	17.80	22.13	25.24	31.42	37.60



Chain bracket

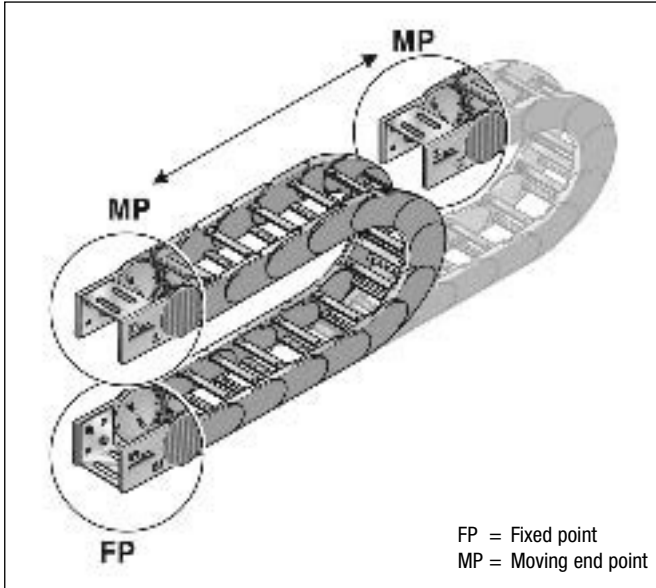

Chain bracket U-part



Top

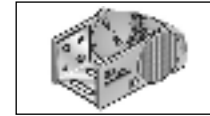

Bottom

Chain bracket angle



Bottom/Outside

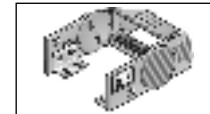

Bottom/Inside

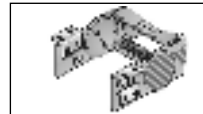

Top/Outside

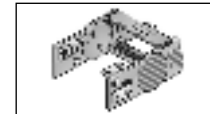

Top/Inside

Chain bracket U-part

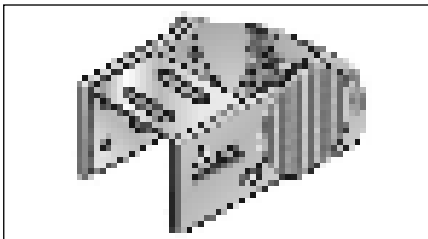

KA 44 U

Type	Order no.	Pack qty.
KA 44 U	0440000054	1

Special for the 1.77 in (45 mm) inside width chain if an inside mounting position is desired. Bracket can be mounted up or down.

Chain bracket angle

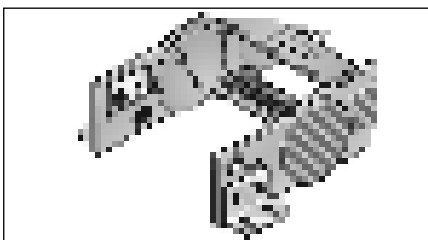

KA 44

Type	Order no.	Material	Pack qty.
KA 44	0440000050	Sheet steel	1
KA 44	0440000052	Stainless steel 1.4301	1

There are several options regarding the chain bracket. The fixed-point bracket (inside/bottom) and the moving end bracket (inside/top) are supplied as standard. However, any other combination can be supplied upon request. The chain bracket is fastened at the end like a side link. This enables the chain to move right up to the bracket. Each chain requires two chain brackets. The brackets should be fastened with M6 screws.

Chain bracket U-part

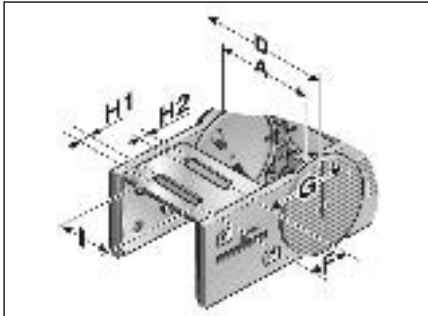

KA 44 U

Type	A inch	D inch	F inch	G inch	H1 inch	H2 inch	I inch
KA 44 U	1.77	3.07	1.10	1.77	0.26	0.33	1.30

Chain bracket angle

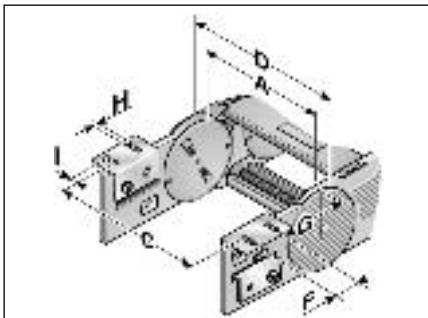

KA 44: Bottom and top/outside

Type	A inch	C inch	D inch	F inch	G inch	H Ø inch	I inch
KA 44	2.44	3.96	3.74	1.26	1.70	0.26	0.49
KA 44	3.31	4.82	4.61	1.26	1.70	0.26	0.49
KA 44	4.13	5.65	5.43	1.26	1.70	0.26	0.49
KA 44	5.67	7.19	6.97	1.26	1.70	0.26	0.49
KA 44	7.17	8.68	8.46	1.26	1.70	0.26	0.49
KA 44	variable	A+1.52	A+1.30	1.26	1.70	0.26	0.49

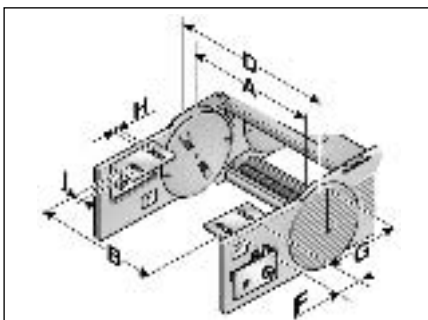

KA 44: Bottom and top/inside

Type	A inch	B inch	D inch	F inch	G inch	H Ø inch	I inch
KA 44	2.44	1.87	3.74	1.26	1.70	0.26	0.49
KA 44	3.31	2.74	4.61	1.26	1.70	0.26	0.49
KA 44	4.13	3.56	5.43	1.26	1.70	0.26	0.49
KA 44	5.67	5.10	6.97	1.26	1.70	0.26	0.49
KA 44	7.17	6.59	8.46	1.26	1.70	0.26	0.49
KA 44	variable	A-0.57	A+1.30	1.26	1.70	0.26	0.49



MP 44 - Accessories

Separator

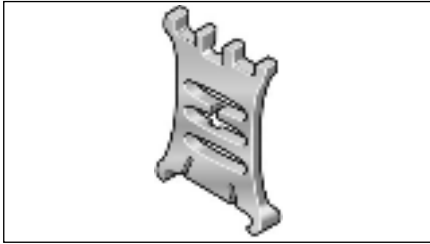

Separator

Type	Order no.	Designation	Pitch inch	Pack qty.
TF 44	044000009400	Separator	0.22	1
TL 44	044000009200	Separator	0.22 for aluminum crossbridges	1

We recommend that separators be used if multiple round cables or conduits with differing diameters are to be installed. An offset configuration of the separators is advisable. The TL 44 should be used for applications with aluminum frame bridges or movable separators.

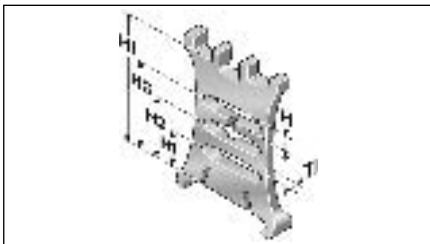

Separator

Type	T1 inch	H inch	H1 inch	H2 inch	H3 inch	HI inch
TF 44	0.16	0.17	0.59	0.88	1.16	1.57
TL 44	0.16	0.17	0.60	0.88	1.16	1.57

Shelving system

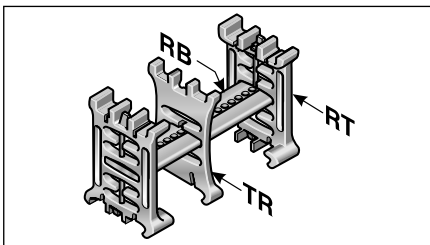

Shelving system

Type	Order no.	Designation	Width inch	Pitch inch	Pack qty.
RB 031	100000003100	RB 031 Shelf	1.22	0.22	1
RB 048	100000004800	RB 048 Shelf	1.89	0.22	1
RB 070	100000007000	RB 070 Shelf	2.76	0.22	1
RB 092	100000009200	RB 092 Shelf	3.62	0.22	1
RB 100	100000010000	RB 100 Shelf	3.94	0.22	1
RB 128	100000012800	RB 128 Shelf	5.04	0.22	1
RB 167	100000016700	RB 167 Shelf	6.57	0.22	1
RT 44	1000902100	RT 44 Shelf support		0.22	incl. pin 1

In connection with at least two shelf supports (RT) the shelf becomes a shelving system. The additional levels prevent cables from criss-crossing and therefore destroying each other, while also avoiding excessive friction. The shelving system may be pre-assembled on request.

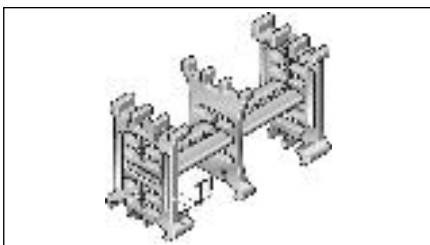

Shelving system

Type	T1 inch
RT 44	0.26

Assembly

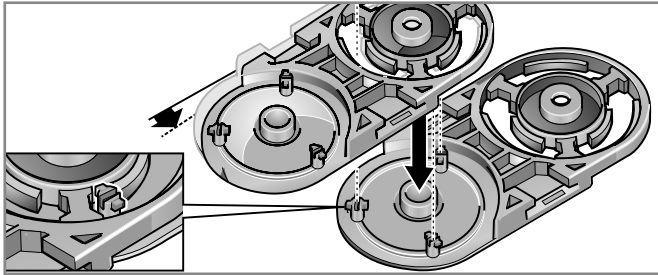

Step 1

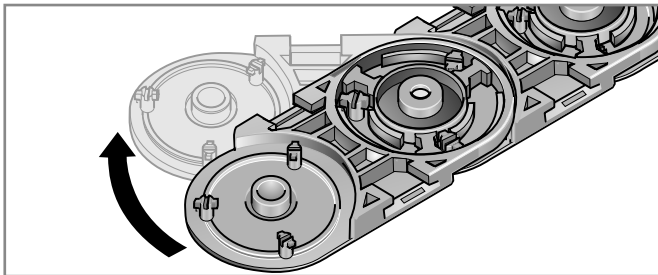

Step 2

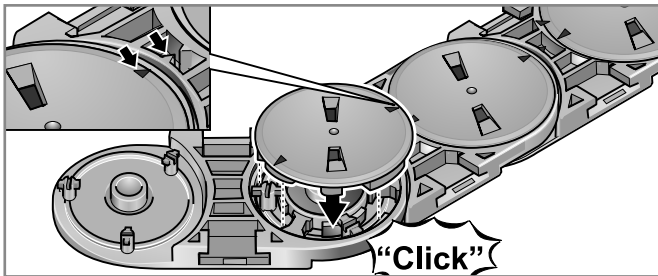

Step 3

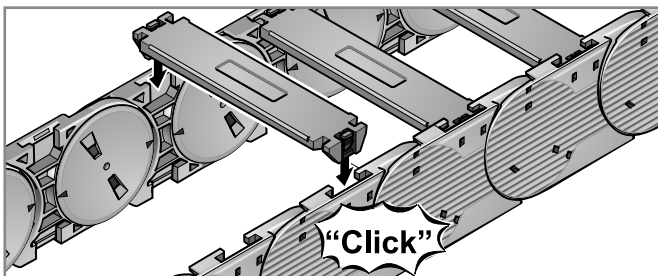

Step 4

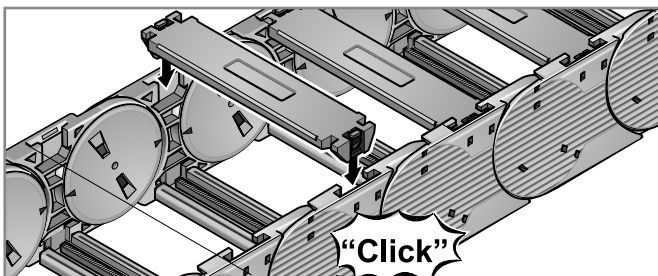

Step 5

Disassembly

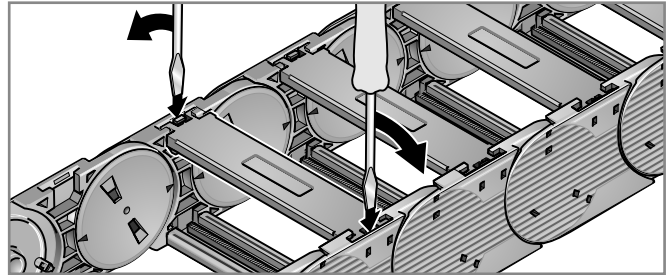

Step 1

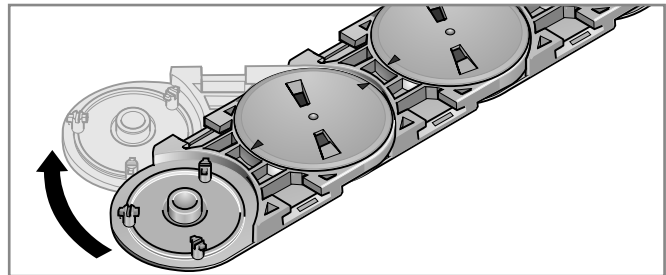

Step 2

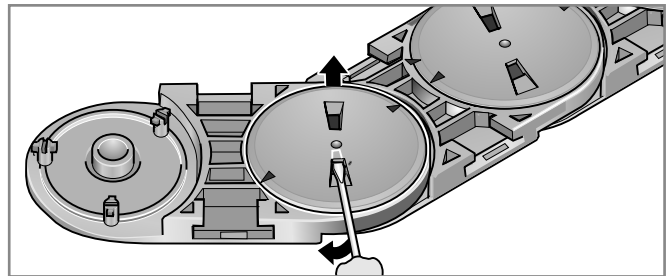

Step 3

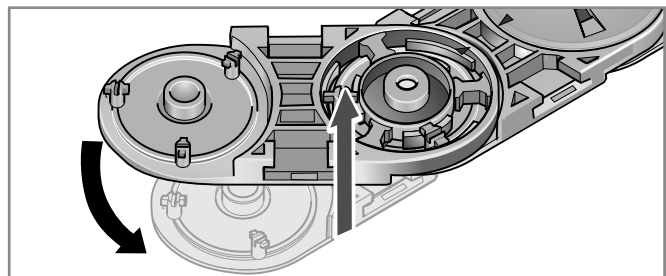

Step 4



Cable drag chain systems

PowerLine

MP 41

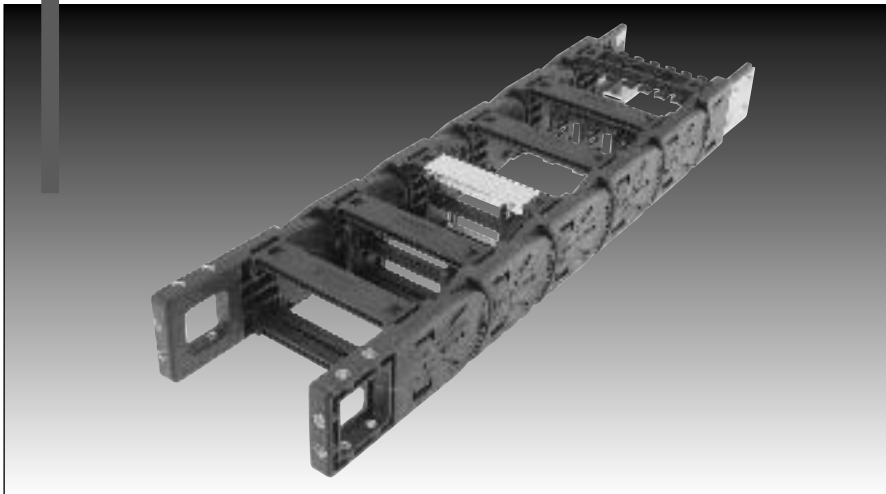



MP 41 - PowerLine

Order variants

Style (order code)									
Configuration (order code) *= standard									
Radius (order code) <small>The radii can be combined with any internal width</small>									
in inch									
Internal width (order code)									
in inch									
Outside width (order code)									
in inch									
MP41 045	3.03	1.77	045						
MP41 062	3.70	2.44	062						
MP41 071	4.06	2.80	071						
MP41 084	4.57	3.31	084						
MP41 096	5.04	3.78	096						
MP41 107	5.47	4.21	107						
MP41 121	6.02	4.76	121						
MP41 133	6.57	5.24	133						
MP41 144	6.93	5.67	144						
MP41 146	7.01	5.75	146						
MP41 158	7.56	6.22	158						
MP41 171	7.99	6.73	171						
MP41 182	8.43	7.17	182						
MP41 196	8.98	7.72	196						
MP41 220	9.92	8.66	220						
MP41 246	10.94	9.69	246						
MP41 296	12.91	11.65	296						
MP41 346	14.88	13.62	346						
MP41 396	16.85	15.59	396	3.54	090			0	
MP41 446	18.82	17.56	446	4.72	120			2*	
MP41 496	20.79	19.53	496	5.91	150			4	
MP41 546	22.76	21.50	546	7.87	200			6	
MP41 xxx	inside + 1.26	>3.15	Alu	9.84	250			9	0
		-23.62		11.81	300				9

Order Number:

Configuration:

- 0 PA crossbar every link; w/bias
- 2* PA crossbar EOL; w/bias
- 4 AL crossbar every link; w/bias
- 6 AL crossbar EOL; w/bias
- 9 Custom version

Style:

- 0 Standard (PA/black)
- 9 Custom version

Sample order:

0410 045 090 0000

Internal width = 1.77 in (45 mm)
 Radius = 3.54 in (90 mm)
 Configuration = 0
 Style = 0

Ideal operating conditions:

- Extreme accelerations
- Extreme speeds
- Extreme self-supporting lengths
- Very high additional loads
- Both sides must be opened
- Aluminum frame bridge in variable lengths
- Flexible internal separation
- Rotated 90° unsupported
- Rotated 90° horizontal

Alternative chain type:

- MP 44 version with/without bias
- MP 41.2 simpler assembly

Features

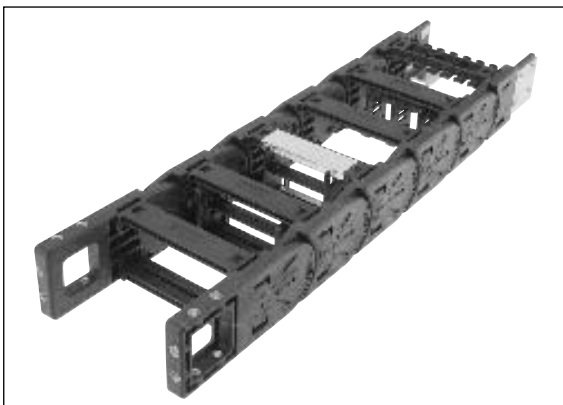

Chain bracket, can be fastened on three sides



Crossbar strain relief can be integrated into chain bracket



Radii with medium bias (R) for all applications



Aluminum frame bridges with integrated lock grid in variable lengths



Chain bracket with variably positionable metal angle



Crossbar/cover can be removed from inside and outside flexure curve



Reverse radius combinations

Technical data

Chain link dimensions (inch) (mm)

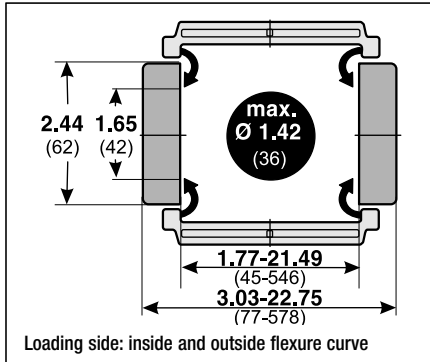

Material characteristics standard (PA/black)

Operating temperature: -22 to 248° F
 Gliding friction factor: 0.30
 Static friction factor: 0.45
 Fire classification: Based on UL94 HB

Other material properties on request

Technical specifications

Travel distance, gliding, L_g : 393.70 ft
 Travel distance, self-supporting, L_s : see diagram
 Travel distance, vertical, hanging, L_{vh} : 328.08 ft
 Travel distance, vertical, upright, L_{vu} : 19.69 ft
 Rotated 90°, self-supporting, L_{90r} : 6.56 ft
 Speed, gliding, V_g : 16.40 ft/s
 Speed, self-supporting, V_s : 65.62 ft/s
 Acceleration, gliding, a_g : 82.02 ft/s²
 Acceleration, self-supporting, a_s : 98.43 ft/s²

Self-supporting length

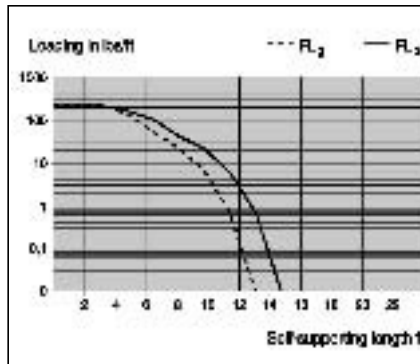
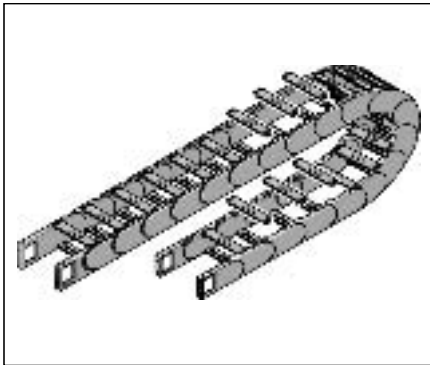

FL₁:
 Ideal installation situation for high stresses at the limit of the max. travel parameters. In this range the chain upper run is still biased, straight or has a max. sag of 0.39 – 1.97 in (10 – 50 mm) depending on the type of chain.

FL₂:
 Satisfactory installation position for many applications working in the lower to middle range of the max. travel parameters. Depending on the chain type, the sag of the chain upper run is >0.39 – 1.97 in (>10 – 50 mm) but certainly less than the max. sag.

If the sag is greater than FL₂, the arrangement is unsuitable and should be avoided. Please choose a more stable Murrplastik cable drag chain.

Determining the chain length

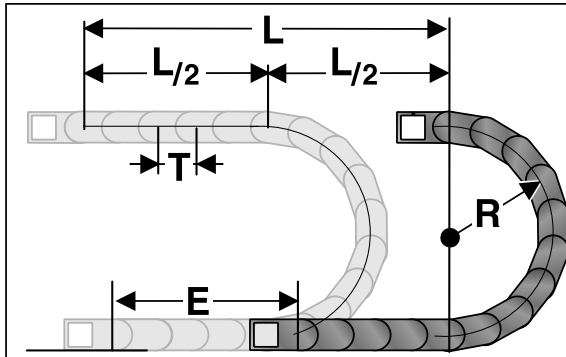

Determining the chain length

$$\text{Length} = \frac{L}{2} + \pi \times R + E$$

≈ 1 ft(m) chain = 4(13) links each 3.03 in (77 mm)

The fixed point of the cable drag chain should be connected in the middle of the travel distance. This arrangement gives the shortest connection between the fixed point and the moving point and thus the most efficient chain length.

Installation dimensions (in inch)

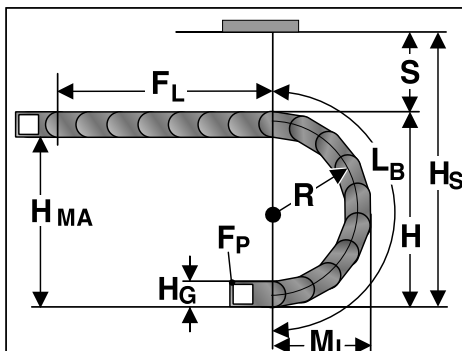

Radius R	3.54	4.72	5.91	7.87	9.84	11.81
Outside height of chain link (H_o)	2.44	2.44	2.44	2.44	2.44	2.44
Height of bend (H)	9.92	12.28	14.65	18.58	22.52	26.46
Height of moving end connection (H_{MA})	7.48	9.84	12.20	16.14	20.08	24.02
Safety margin (S)	1.18	1.18	1.18	1.18	1.18	1.18
Installation height (H_s)	11.10	13.46	15.83	19.76	23.70	27.64
Arc projection (M_L)	7.99	9.17	10.35	12.32	14.29	16.26
Bend length (L_b)	18.62	22.32	26.02	32.20	38.39	44.57



Chain bracket

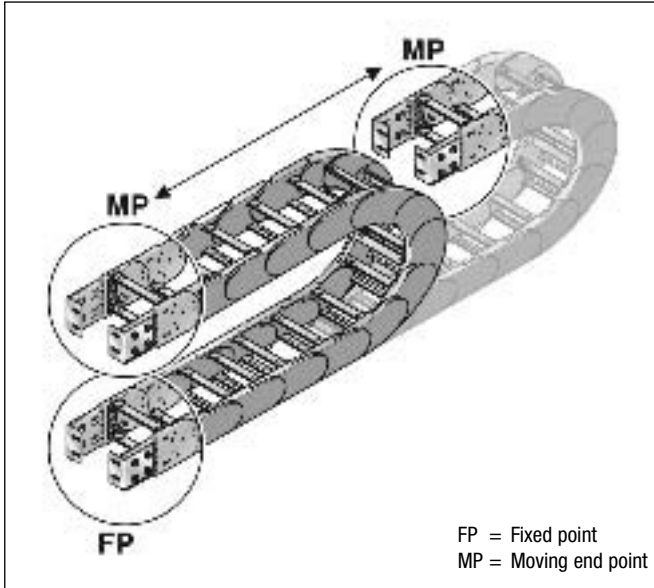

Flexible chain bracket

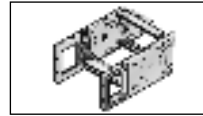

Chain bracket angle

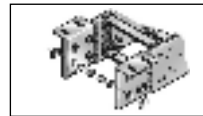

Top/Outside

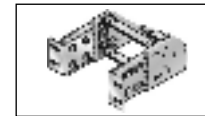

Front/Outside

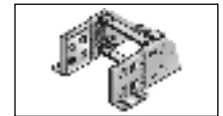

Bottom/Outside

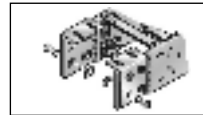

Top/Inside

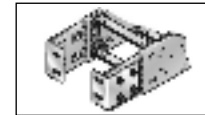

Front/Inside

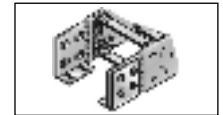

Bottom/Inside

Flexible chain bracket

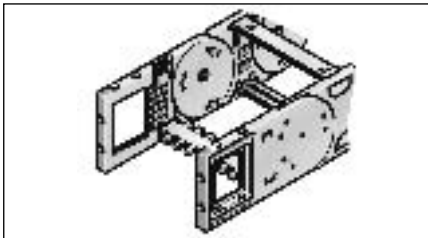

KA 41...

Type	Order no.	Version	Pack qty.
KA 41-FB	0411000054	with bushing	1
KA 41-FG	0411000055	with thread	1

This chain bracket offers universal connection options (top, bottom and front) and is attached to the ends of the chain like a side link. This allows the chain to move right up to the bracket. Each chain requires one male and one female bracket. M6 screws are used to secure the brackets in place. Extrusion-coated metal bushings with either a through-hole (-FB) or a threaded hole (-FG) ensure the permanent, high-strength transmission of even extreme forces onto the cable drag chain.

Chain bracket angle

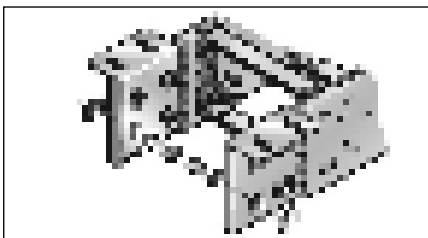

KA 41

Type	Order no.	Pack qty.
KA 41	0410000051	1

There are several options regarding the chain bracket. The fixed-point bracket (inside/bottom) and the moving end bracket (inside/top) are supplied as standard. However, any other combination can be supplied upon request. The chain bracket is fastened at the end like a side link. This enables the chain to move right up to the bracket. Each chain requires two chain brackets. The brackets should be fastened with M6 screws.

Flexible chain bracket

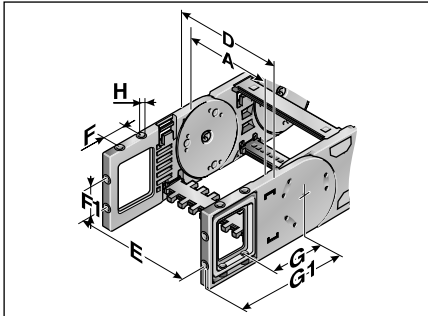

Flexible with through-hole

Type	A inch	D inch	E inch	F inch	F1 inch	G inch	G1 inch	H Ø inch
KA 41-FB	1.77	3.11	2.56	0.89	0.87	3.11	4.72	0.26
KA 41-FB	2.44	3.78	3.23	0.89	0.87	3.11	4.72	0.26
KA 41-FB	2.80	4.13	3.58	0.89	0.87	3.11	4.72	0.26
KA 41-FB	3.31	4.65	4.09	0.89	0.87	3.11	4.72	0.26
KA 41-FB	3.78	5.12	4.57	0.89	0.87	3.11	4.72	0.26
KA 41-FB	4.21	5.55	5.00	0.89	0.87	3.11	4.72	0.26
KA 41-FB	4.76	6.10	5.55	0.89	0.87	3.11	4.72	0.26
KA 41-FB	5.24	6.57	6.06	0.89	0.87	3.11	4.72	0.26
KA 41-FB	5.67	7.01	6.46	0.89	0.87	3.11	4.72	0.26
KA 41-FB	5.75	7.09	6.54	0.89	0.87	3.11	4.72	0.26
KA 41-FB	6.22	7.56	7.01	0.89	0.87	3.11	4.72	0.26
KA 41-FB	6.73	8.07	7.52	0.89	0.87	3.11	4.72	0.26
KA 41-FB	7.17	8.50	7.95	0.89	0.87	3.11	4.72	0.26
KA 41-FB	7.72	9.06	8.50	0.89	0.87	3.11	4.72	0.26
KA 41-FB	8.66	10.00	9.45	0.89	0.87	3.11	4.72	0.26
KA 41-FB	9.69	11.02	10.47	0.89	0.87	3.11	4.72	0.26
KA 41-FB	11.65	12.99	12.44	0.89	0.87	3.11	4.72	0.26
KA 41-FB	13.62	14.96	14.41	0.89	0.87	3.11	4.72	0.26
KA 41-FB	15.59	16.93	16.38	0.89	0.87	3.11	4.72	0.26
KA 41-FB	17.56	18.90	18.35	0.89	0.87	3.11	4.72	0.26
KA 41-FB	19.53	20.87	20.31	0.89	0.87	3.11	4.72	0.26
KA 41-FB	21.50	22.83	22.28	0.89	0.87	3.11	4.72	0.26
KA 41-FB	variable	A+1.34	A+0.79	0.89	0.87	3.11	4.72	0.26

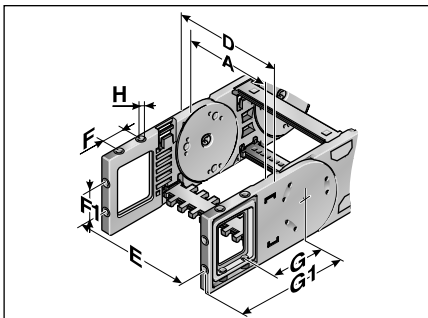

Flexible with threaded bushing

Type	A inch	D inch	E inch	F inch	F1 inch	G inch	G1 inch	H
KA 41-FG	1.77	3.11	2.56	0.89	0.87	3.11	4.72	M6
KA 41-FG	2.44	3.78	3.23	0.89	0.87	3.11	4.72	M6
KA 41-FG	2.80	4.13	3.58	0.89	0.87	3.11	4.72	M6
KA 41-FG	3.31	4.65	4.09	0.89	0.87	3.11	4.72	M6
KA 41-FG	3.78	5.12	4.57	0.89	0.87	3.11	4.72	M6
KA 41-FG	4.21	5.55	5.00	0.89	0.87	3.11	4.72	M6
KA 41-FG	4.76	6.10	5.55	0.89	0.87	3.11	4.72	M6
KA 41-FG	5.24	6.57	6.06	0.89	0.87	3.11	4.72	M6
KA 41-FG	5.67	7.01	6.46	0.89	0.87	3.11	4.72	M6
KA 41-FG	5.75	7.09	6.54	0.89	0.87	3.11	4.72	M6
KA 41-FG	6.22	7.56	7.01	0.89	0.87	3.11	4.72	M6
KA 41-FG	6.73	8.07	7.52	0.89	0.87	3.11	4.72	M6
KA 41-FG	7.17	8.50	7.95	0.89	0.87	3.11	4.72	M6
KA 41-FG	7.72	9.06	8.50	0.89	0.87	3.11	4.72	M6
KA 41-FG	8.66	10.00	9.45	0.89	0.87	3.11	4.72	M6
KA 41-FG	9.69	11.02	10.47	0.89	0.87	3.11	4.72	M6
KA 41-FG	11.65	12.99	12.44	0.89	0.87	3.11	4.72	M6
KA 41-FG	13.62	14.96	14.41	0.89	0.87	3.11	4.72	M6
KA 41-FG	15.59	16.93	16.38	0.89	0.87	3.11	4.72	M6
KA 41-FG	17.56	18.90	18.35	0.89	0.87	3.11	4.72	M6
KA 41-FG	19.53	20.87	20.31	0.89	0.87	3.11	4.72	M6
KA 41-FG	21.50	22.83	22.28	0.89	0.87	3.11	4.72	M6
KA 41-FG	variable	A+1.34	A+0.79	0.89	0.87	3.11	4.72	M6



Chain bracket angle

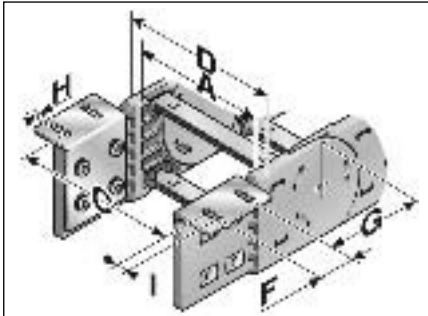

Bottom and top/outside

Type	A inch	C inch	D inch	F inch	G inch	H Ø inch	I inch
KA 41	1.77	3.13	3.03	1.26	3.11	0.26	0.55
KA 41	2.44	3.80	3.70	1.26	3.11	0.26	0.55
KA 41	2.80	4.15	4.06	1.26	3.11	0.26	0.55
KA 41	3.31	4.67	4.57	1.26	3.11	0.26	0.55
KA 41	3.78	5.14	5.04	1.26	3.11	0.26	0.55
KA 41	4.21	5.57	5.47	1.26	3.11	0.26	0.55
KA 41	4.76	6.12	6.02	1.26	3.11	0.26	0.55
KA 41	5.24	6.59	6.5	1.26	3.11	0.26	0.55
KA 41	5.67	7.03	6.93	1.26	3.11	0.26	0.55
KA 41	5.75	7.11	7.01	1.26	3.11	0.26	0.55
KA 41	6.22	7.58	7.48	1.26	3.11	0.26	0.55
KA 41	6.73	8.09	7.99	1.26	3.11	0.26	0.55
KA 41	7.17	8.52	8.39	1.26	3.11	0.26	0.55
KA 41	7.72	9.07	8.98	1.26	3.11	0.26	0.55
KA 41	8.66	10.02	9.92	1.26	3.11	0.26	0.55
KA 41	9.69	11.04	10.94	1.26	3.11	0.26	0.55
KA 41	11.65	13.01	12.91	1.26	3.11	0.26	0.55
KA 41	13.62	14.98	14.88	1.26	3.11	0.26	0.55
KA 41	15.59	16.95	16.85	1.26	3.11	0.26	0.55
KA 41	17.56	18.92	18.82	1.26	3.11	0.26	0.55
KA 41	19.53	20.89	20.79	1.26	3.11	0.26	0.55
KA 41	21.50	22.85	22.76	1.26	3.11	0.26	0.55
KA 41	variable	A+1.36	A+1.26	1.26	3.11	0.26	0.55

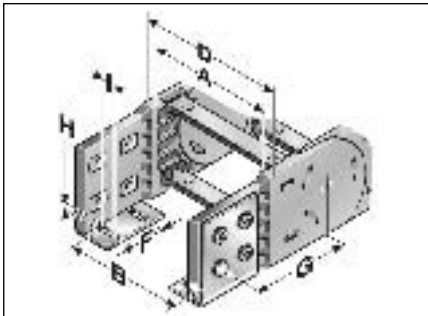

Bottom and top/inside

Type	A inch	B inch	D inch	F inch	G inch	H Ø inch	I inch
KA 41	1.77	1.67	3.03	1.26	3.11	0.26	0.55
KA 41	2.44	2.34	3.70	1.26	3.11	0.26	0.55
KA 41	2.80	2.70	4.06	1.26	3.11	0.26	0.55
KA 41	3.31	3.21	4.57	1.26	3.11	0.26	0.55
KA 41	3.78	3.68	5.04	1.26	3.11	0.26	0.55
KA 41	4.21	4.11	5.47	1.26	3.11	0.26	0.55
KA 41	4.76	4.67	6.02	1.26	3.11	0.26	0.55
KA 41	5.24	5.14	6.5	1.26	3.11	0.26	0.55
KA 41	5.67	5.57	6.93	1.26	3.11	0.26	0.55
KA 41	5.75	5.65	7.01	1.26	3.11	0.26	0.55
KA 41	6.22	6.12	7.48	1.26	3.11	0.26	0.55
KA 41	6.73	6.63	7.99	1.26	3.11	0.26	0.55
KA 41	7.17	7.07	8.39	1.26	3.11	0.26	0.55
KA 41	7.72	7.62	8.98	1.26	3.11	0.26	0.55
KA 41	8.66	8.56	9.92	1.26	3.11	0.26	0.55
KA 41	9.69	9.59	10.94	1.26	3.11	0.26	0.55
KA 41	11.65	11.56	12.91	1.26	3.11	0.26	0.55
KA 41	13.62	13.52	14.88	1.26	3.11	0.26	0.55
KA 41	15.59	15.49	16.85	1.26	3.11	0.26	0.55
KA 41	17.56	17.46	18.82	1.26	3.11	0.26	0.55
KA 41	19.53	19.43	20.79	1.26	3.11	0.26	0.55
KA 41	21.50	21.40	22.76	1.26	3.11	0.26	0.55
KA 41	variable	A-0.10	A+1.26	1.26	3.11	0.26	0.55

Chain bracket angle

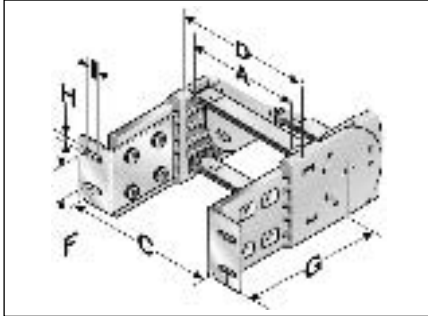

Front/Outside

Type	A inch	C inch	D inch	F inch	G inch	H Ø inch	I inch
KA 41	1.77	3.13	3.03	1.26	4.95	0.26	0.55
KA 41	2.44	3.80	3.70	1.26	4.95	0.26	0.55
KA 41	2.80	4.15	4.06	1.26	4.95	0.26	0.55
KA 41	3.31	4.67	4.57	1.26	4.95	0.26	0.55
KA 41	3.78	5.14	5.04	1.26	4.95	0.26	0.55
KA 41	4.21	5.57	5.47	1.26	4.95	0.26	0.55
KA 41	4.76	6.12	6.02	1.26	4.95	0.26	0.55
KA 41	5.24	6.59	6.5	1.26	4.95	0.26	0.55
KA 41	5.67	7.03	6.93	1.26	4.95	0.26	0.55
KA 41	5.75	7.11	7.01	1.26	4.95	0.26	0.55
KA 41	6.22	7.58	7.48	1.26	4.95	0.26	0.55
KA 41	6.73	8.09	7.99	1.26	4.95	0.26	0.55
KA 41	7.17	8.52	8.39	1.26	4.95	0.26	0.55
KA 41	7.72	9.07	8.98	1.26	4.95	0.26	0.55
KA 41	8.66	10.02	9.92	1.26	4.95	0.26	0.55
KA 41	9.69	11.04	10.94	1.26	4.95	0.26	0.55
KA 41	11.65	13.01	12.91	1.26	4.95	0.26	0.55
KA 41	13.62	14.98	14.88	1.26	4.95	0.26	0.55
KA 41	15.59	16.95	16.85	1.26	4.95	0.26	0.55
KA 41	17.56	18.92	18.82	1.26	4.95	0.26	0.55
KA 41	19.53	20.89	20.79	1.26	4.95	0.26	0.55
KA 41	21.50	22.85	22.76	1.26	4.95	0.26	0.55
KA 41	variable	A+1.36	A+1.26	1.26	4.95	0.26	0.55

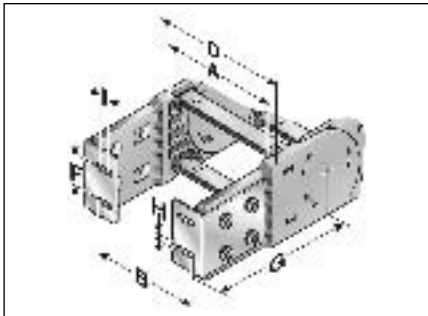

Front/Inside

Type	A inch	B inch	D inch	F inch	G inch	H Ø inch	I inch
KA 41	1.77	1.67	3.03	1.26	4.95	0.26	0.55
KA 41	2.44	2.34	3.70	1.26	4.95	0.26	0.55
KA 41	2.80	2.70	4.06	1.26	4.95	0.26	0.55
KA 41	3.31	3.21	4.57	1.26	4.95	0.26	0.55
KA 41	3.78	3.68	5.04	1.26	4.95	0.26	0.55
KA 41	4.21	4.11	5.47	1.26	4.95	0.26	0.55
KA 41	4.76	4.67	6.02	1.26	4.95	0.26	0.55
KA 41	5.24	5.14	6.5	1.26	4.95	0.26	0.55
KA 41	5.67	5.57	6.93	1.26	4.95	0.26	0.55
KA 41	5.75	5.65	7.01	1.26	4.95	0.26	0.55
KA 41	6.22	6.12	7.48	1.26	4.95	0.26	0.55
KA 41	6.73	6.63	7.99	1.26	4.95	0.26	0.55
KA 41	7.17	7.07	8.39	1.26	4.95	0.26	0.55
KA 41	7.72	7.62	8.98	1.26	4.95	0.26	0.55
KA 41	8.66	8.56	9.92	1.26	4.95	0.26	0.55
KA 41	9.69	9.59	10.94	1.26	4.95	0.26	0.55
KA 41	11.65	11.56	12.91	1.26	4.95	0.26	0.55
KA 41	13.62	13.52	14.88	1.26	4.95	0.26	0.55
KA 41	15.59	15.49	16.85	1.26	4.95	0.26	0.55
KA 41	17.56	17.46	18.82	1.26	4.95	0.26	0.55
KA 41	19.53	19.43	20.79	1.26	4.95	0.26	0.55
KA 41	21.50	21.40	22.76	1.26	4.95	0.26	0.55
KA 41	variable	A-0.10	A+1.26	1.26	4.95	0.26	0.55



Assembly instruction flexible chain bracket

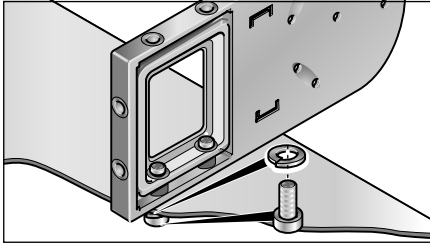

Chain bracket with threaded bushing

Brass bushings guarantee long-lasting fastening without cold flow in the plastic.

Version KA-FB:

Integrated through-hole fastened down using screw and nut.

Version KA-FG:

Built-in threads allow for quick and easy on-site mounting, since a screw, including a retaining washer where necessary, is sufficient.

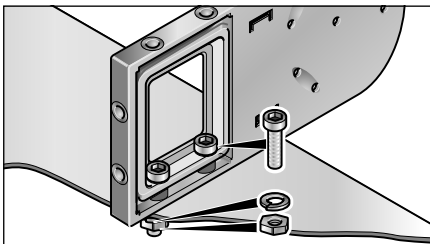

Chain bracket with bushing

Separator



Separator

Type	Order no.	Designation	Pitch inch	Pack qty.
TR 41	041000009200	Separator	0.22	1

We recommend that separators be used if multiple round cables or conduits with differing diameters are to be installed. An offset configuration of the separators is advisable.

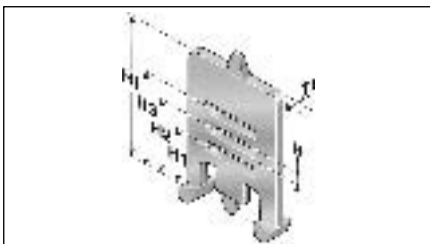

Separator

Type	T1 inch	H1 inch	H2 inch	H3 inch	H1 inch
TR 41	0.14	0.63	0.90	1.14	1.65

H-shaped shelf unit

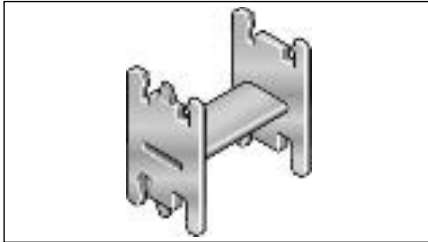

H-shaped shelf unit

Type	Order no.	Designation	Pitch inch	Pack qty.
RE 36/11	100000361112	RE 36/11 H-shaped shelf unit	0.22	1
RE 59/18	100000591812	RE 59/18 H-shaped shelf unit	0.22	1
RE 81/11	100000811112	RE 81/11 H-shaped shelf unit	0.22	1

Insert to obtain additional levels in pre-defined distances.

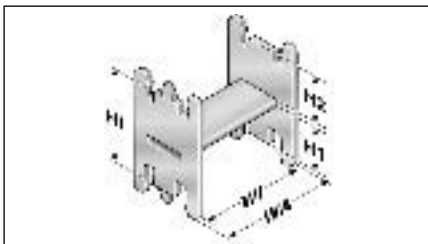

H-shaped shelf unit

Type	WA inch	WI inch	H1 inch	H2 inch	HI inch
RE 36/11	1.67	1.44	1.03	0.45	1.65
RE 59/18	2.56	2.32	0.74	0.74	1.65
RE 81/11	3.44	3.21	1.03	0.45	1.65

Shelving system

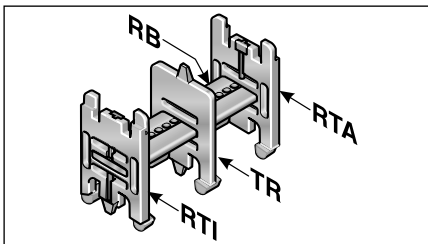

Shelving system

Type	Order no.	Designation	Width inch	Pitch inch	Pack qty.
RB 031	100000003100	RB 031 Shelf	1.22	0.22	1
RB 048	100000004800	RB 048 Shelf	1.89	0.22	1
RB 070	100000007000	RB 070 Shelf	2.76	0.22	1
RB 092	100000009200	RB 092 Shelf	3.62	0.22	1
RB 128	100000012800	RB 128 Shelf	5.04	0.22	1
RB 167	100000016700	RB 167 Shelf	6.57	0.22	1
RB 218	100000021800	RB 218 Shelf	8.58	0.22	1
RTA 41	1000810100	RTA 41 Shelf support, external, incl. pin		0.22	1
RTI 41	1000909100	RTI 41 Shelf support, internal, incl. pin		0.22	1

In connection with at least two shelf supports (RTI/RTA) the shelf becomes a shelving system. The additional levels prevent cables from criss-crossing and therefore destroying each other, while also avoiding excessive friction. The shelf system can be pre-assembled on request.

RTA shelf supports are positioned on the outer edge of the internal chain compartment.

RTI shelf supports are positioned in the center of the internal chain compartment in case the shelf system does not span the entire width.

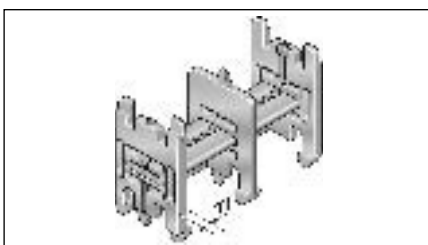

Shelving system

Type	T1 inch
RTA/RTI	0.24



Crossbar connector

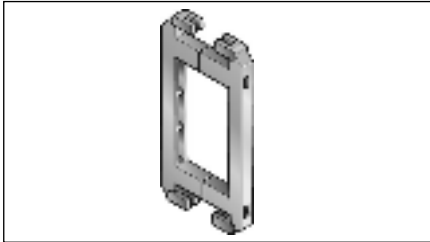

Crossbar connector

Type	Order no.	Designation	Pack qty.
RSV 41	041000009600	RSV 41 Crossbar connector	1
RSV 41 Alu	041000009800	RSV 41 Crossbar connector for aluminum crossbridges	1

For frame bridges wider than 9.69 in (246 mm), we recommend the use of crossbar connectors. These prevent deformation to the frame bridge under large amounts of additional weight of the chain assembly.

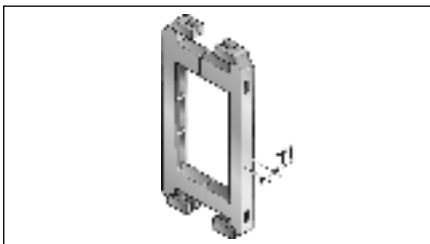

Type	TI inch
RSV 41	0.30
RSV 41 Alu	0.30

Crossbar strain relief plate RS-ZL

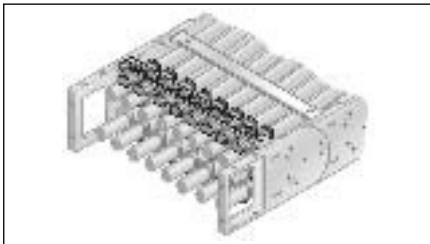

Crossbar strain relief plate RS-ZL

Type	Order no.	For internal width inch	Pack qty.
RS-ZL 045-5	052004500010	1.77	1
RS-ZL 062-5	052006200010	2.44	1
RS-ZL 071-5	052007100010	2.80	1
RS-ZL 084-5	052008400010	3.31	1
RS-ZL 096-5	052009600010	3.78	1
RS-ZL 107-5	052010700010	4.21	1
RS-ZL 121-5	052012100010	4.76	1
RS-ZL 133-5	052013300010	5.24	1
RS-ZL 5.67/5.75-5	052014400010	5.67/5.75	1
RS-ZL 158-5	052015800010	6.22	1
RS-ZL 171-5	052017100010	6.73	1
RS-ZL 182-5	052018200010	7.17	1
RS-ZL 196-5	052019600010	7.72	1
RS-ZL 220-5	052022000010	8.66	1
RS-ZL 246-5	052024600010	9.69	1

Fixed integrated frame bridge strain relief plates in the chain brackets. Tailored to all frame bridge widths up to 9.69 in (246 mm). May be assembled on the inside and outside flexure curves at both chain endings.

Strain relief type BAK

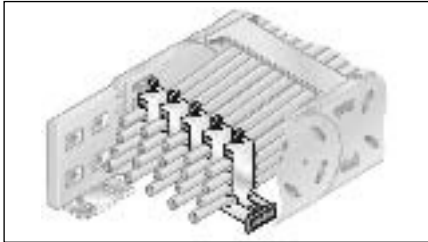

Strain relief with hooped clamp

Type	Order no.	Designation	Ø inch	Number of seats	Pack qty.
C-rail	81661610	C-profile rail			1
BA 12	81661036	BA 12 Hooped clamp	0.35–0.47	1	1
BAK 14	81661002	BAK 14 Hooped clamp	0.24–0.55	1	1
BAK 18	81661004	BAK 18 Hooped clamp	0.55–0.71	1	1
BAK 22	81661006	BAK 22 Hooped clamp	0.71–0.87	1	1
BAK 26	81661008	BAK 26 Hooped clamp	0.87–1.02	1	1
BAK 30	81661010	BAK 30 Hooped clamp	1.02–1.18	1	1
BAK 34	81661000	BAK 34 Hooped clamp	1.18–1.34	1	1
BAK 38	81661044	BAK 38 Hooped clamp	1.34–1.50	1	1
BAK 42	81661032	BAK 42 Hooped clamp	1.50–1.65	1	1
BAK 46	81661050	BAK 46 Hooped clamp	1.65–1.81	1	1
BA 12/2	81661038	BA 12/2 Hooped clamp	0.35–0.47	2	1
BAK 14/2	81661012	BAK 14/2 Hooped clamp	0.39–0.55	2	1
BAK 18/2	81661014	BAK 18/2 Hooped clamp	0.55–0.71	2	1
BAK 22/2	81661016	BAK 22/2 Hooped clamp	0.71–0.87	2	1
BAK 26/2	81661018	BAK 26/2 Hooped clamp	0.87–1.02	2	1
BAK 30/2	81661048	BAK 30/2 Hooped clamp	1.02–1.18	2	1
BAK 34/2	81661044	BAK 34/2 Hooped clamp	1.18–1.34	2	1
BAK 38/2	81661046	BAK 38/2 Hooped clamp	1.34–1.50	2	1
BAK 42/2	81661034	BAK 42/2 Hooped clamp	1.50–1.65	2	1
BAK 12/3	81661020	BAK 12/3 Hooped clamp	0.35–0.47	3	1
BAK 14/3	81661022	BAK 14/3 Hooped clamp	0.47–0.55	3	1
BAK 16/3	81661024	BAK 16/3 Hooped clamp	0.55–0.63	3	1
BAK 18/3	81661026	BAK 18/3 Hooped clamp	0.63–0.71	3	1
BAK 20/3	81661028	BAK 20/3 Hooped clamp	0.71–0.79	3	1
BAK 22/3	81661030	BAK 22/3 Hooped clamp	0.79–0.87	3	1

Fixed integrated strain relief in the chain connections. Available in all widths (also individual widths for aluminum frame ridges). May be assembled on the inside and outside flexure curves at both chain endings. Chain content is secured through hooped clamps that are available in different sizes. Material: Galvanized steel.

When ordering please indicate the type of chain and internal width.



Reverse radius

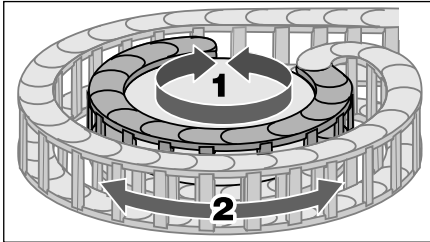

Rotating movement

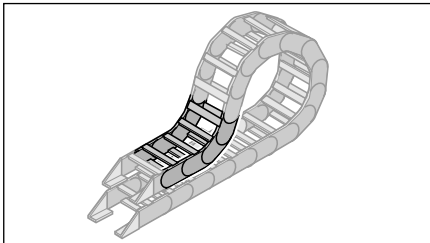

lowered chain bracket

Type	Order no.	Radius inch	Reverse radius inch	Pack qty.
SR 41 (RÜ200/R125)	41000009060	4.92	7.87	1
SR 41 (RÜ200/R160)	41000012060	6.30	7.87	1
SR 41 (RÜ200/R175)	41000015060	6.89	7.87	1
SR 41 (RÜ200/R200)	41000020060	7.87	7.87	1
SR 41 (RÜ200/R250)	41000025060	9.84	7.87	1
SR 41 (RÜ200/R300)	41000030060	11.81	7.87	1
SR 41 (RÜ200/R350)	41000035060	13.78	7.87	1

Side links with radius forward (R) and radius backward (Rü) allow for movement in two directions. This is intended for rotating movements and lowered chain brackets.

Assembly

Disassembly

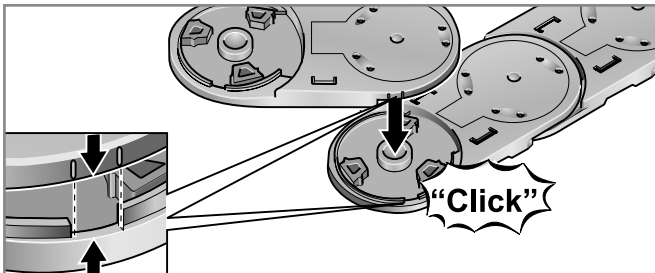

Step 1

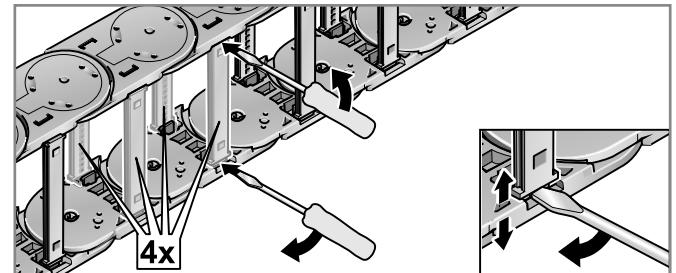

Step 1

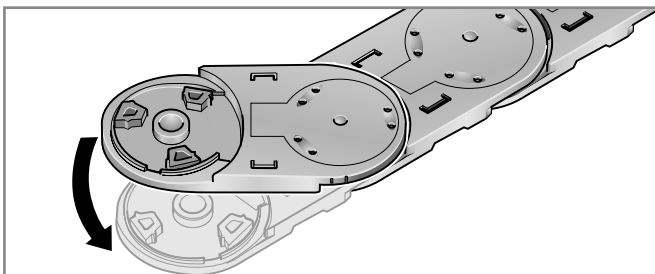

Step 2

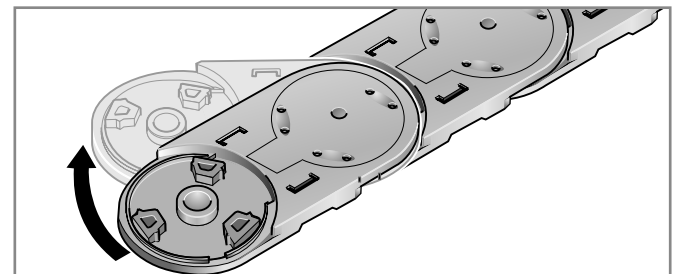

Step 2

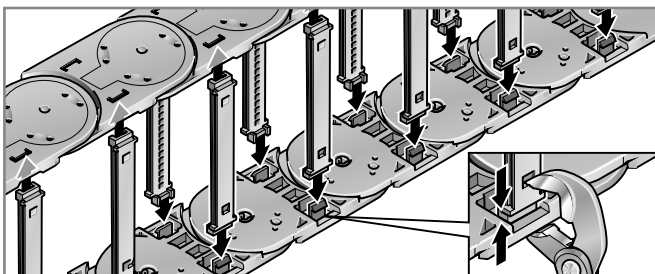

Step 3

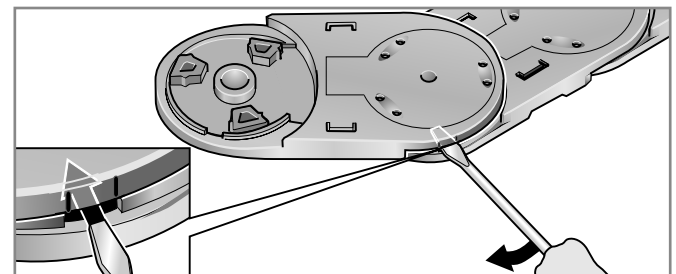

Step 3

Cable drag chain systems

PowerLine

MP 41.2

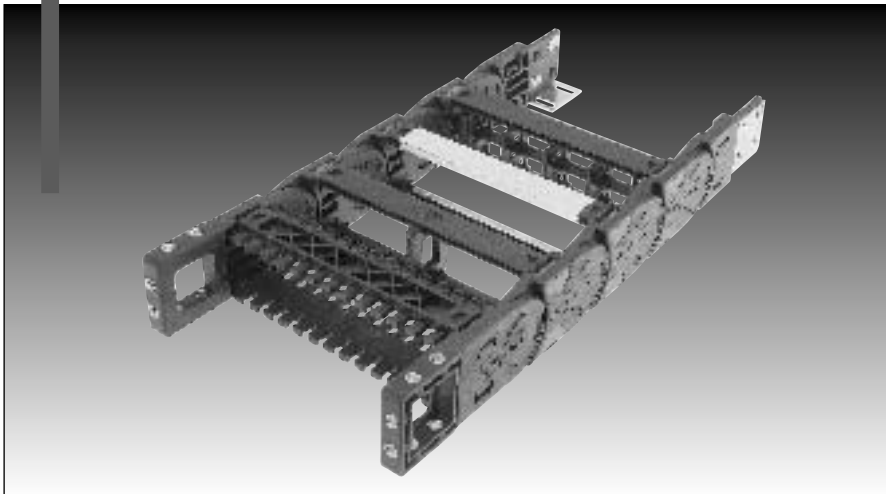



MP 41.2 - PowerLine 2nd generation

Order variants

Style (order code)

Configuration (order code) * = standard

Radius (order code) The radii can be combined with any internal width

in inch

Internal width (order code)

in inch

Outside width (order code)

in inch

MP41.2 045	3.03	1.77	045						
MP41.2 062	3.70	2.44	062						
MP41.2 071	4.06	2.80	071						
MP41.2 084	4.57	3.31	084						
MP41.2 096	5.04	3.78	096						
MP41.2 107	5.47	4.21	107						
MP41.2 121	6.02	4.76	121						
MP41.2 133	6.57	5.24	133						
MP41.2 144	6.93	5.67	144						
MP41.2 146	7.01	5.75	146						
MP41.2 158	7.56	6.22	158						
MP41.2 171	7.99	6.73	171						
MP41.2 182	8.43	7.17	182						
MP41.2 196	8.98	7.72	196						
MP41.2 220	9.92	8.66	220						
MP41.2 246	10.94	9.69	246						
MP41.2 296	12.91	11.65	296						
MP41.2 346	14.88	13.62	346						
MP41.2 396	16.85	15.59	396	3.54	090			0	
MP41.2 446	18.82	17.56	446	4.72	120			1	
MP41.2 496	20.79	19.53	496	5.91	150			2*	
MP41.2 546	22.76	21.50	546	7.87	200			3*	
MP41.2 xxx	inside + 1.26	>3.15	Alu	9.84	250			4	0
				11.81	300			5	5
								6	7
								7	7
								9	9

Order-Number:

Configuration:

- 0 PA crossbar every link; w/bias
- 1 PA crossbar every link; w/o bias
- 2* PA crossbar EOL; w/bias
- 3* PA crossbar EOL; w/o bias
- 4 AL crossbar every link; w/bias
- 5 AL crossbar every link; w/o bias
- 6 AL crossbar EOL; w/bias
- 7 AL crossbar EOL; w/o bias
- 9 Custom version

Style:

- 0 Standard (PA/black)
- 5 Polypropylene (PP/blue)
- 7 ESD (PA/light gray)
- 9 Custom version

Sample order:

0412 045 090 0000

Internal width = 1.77 in (45 mm)
 Radius = 3.54 in (90 mm)
 Configuration = 0
 Style = 0

Ideal operating conditions:

- Extreme accelerations
- Extreme speeds
- Very high additional loads
- Both sides must be opened
- Aluminum frame bridge in variable lengths
- Flexible internal separation

Alternative chain type:

- MP 44 version with/without bias
- MP 41 greater unsupported length

Features

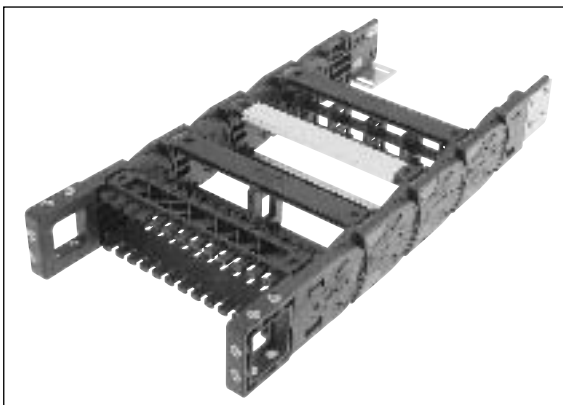

- Chain bracket, can be fastened on three sides
- Chain bracket with variably positionable metal angle
- Crossbar/cover can be removed from inside and outside flexure curve
- Side links with CLICK lock for easy opening
- Radii with or without bias (RK/RV)
- Crossbar strain relief can be integrated into chain bracket
- Aluminum frame bridges with integrated lock grid in variable lengths
- ESD cable drag chains for use in areas at risk of explosion
- Reverse radius combinations
- Foldable shelf system for reliable cable guidance

Technical data

Chain link dimensions (inch) (mm)

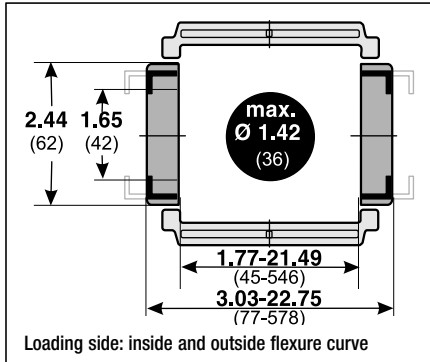

Material characteristics standard (PA/black)

Operating temperature: -22 to 248° F
 Gliding friction factor: 0.30
 Static friction factor: 0.45
 Fire classification: Based on UL94 HB

Other material properties on request

Technical specifications

Travel distance, gliding, L_g : 393.70 ft
 Travel distance, self-supporting, L_s : see diagram
 Travel distance, vertical, hanging, L_{vh} : 328.08 ft
 Travel distance, vertical, upright, L_{vu} : 19.69 ft
 Rotated 90°, self-supporting, L_{90r} : 3.28 ft
 Speed, gliding, V_g : 16.40 ft/s
 Speed, self-supporting, V_s : 65.62 ft/s
 Acceleration, gliding, a_g : 82.02 ft/s²
 Acceleration, self-supporting, a_s : 98.43 ft/s²

Self-supporting length

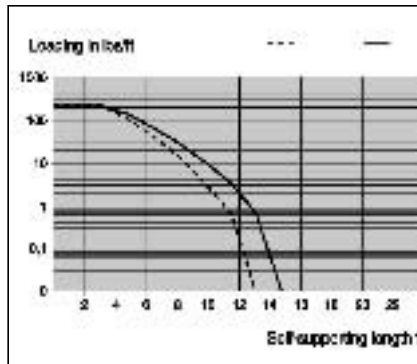
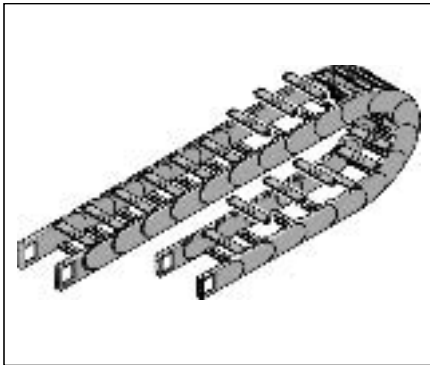

FL_g:
 Ideal installation situation for high stresses at the limit of the max. travel parameters. In this range the chain upper run is still biased, straight or has a max. sag of 0.39 – 1.97 in (10 – 50 mm) depending on the type of chain.

FL_s:
 Satisfactory installation position for many applications working in the lower to middle range of the max. travel parameters. Depending on the chain type, the sag of the chain upper run is >0.39 – 1.97 in (>10 – 50 mm) but certainly less than the max. sag.

If the sag is greater than FL_s, the arrangement is unsuitable and should be avoided. Please choose a more stable Murrplastik cable drag chain.

Determining the chain length

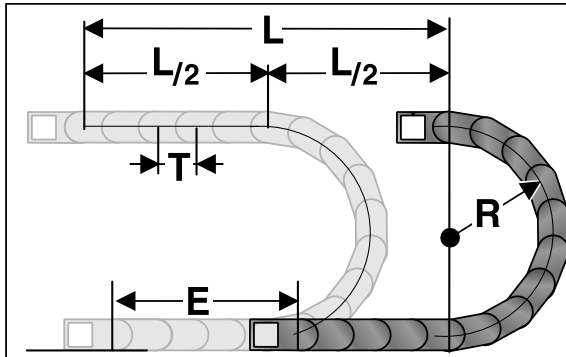

Determining the chain length

$$\text{Length} = \frac{L}{2} + \pi \times R + E$$

≈ 1 ft(m) chain = 4(13) links each 3.03 in (77 mm)

The fixed point of the cable drag chain should be connected in the middle of the travel distance. This arrangement gives the shortest connection between the fixed point and the moving point and thus the most efficient chain length.

Installation dimensions (in inch)

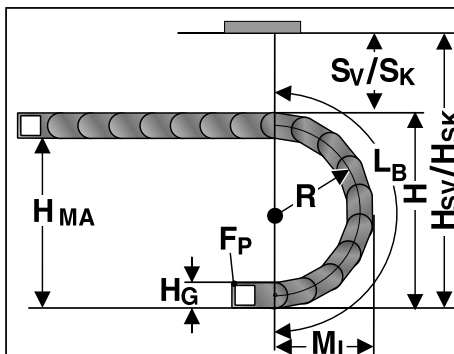

Radius R	3.54	4.72	5.91	7.87	9.84	11.81
Outside height of chain link (H_o)	2.44	2.44	2.44	2.44	2.44	2.44
Height of bend (H)	9.92	12.28	14.65	18.58	22.52	26.46
Height of moving end connection (H_{ma})	7.48	9.84	12.28	16.14	20.08	24.02
Safety margin with bias (S_v)	1.18	1.18	1.18	1.18	1.18	1.18
Installation height with bias (H_{sv})	11.10	13.46	15.83	19.76	23.70	27.64
Safety margin without bias (S_k)	0.59	0.59	0.59	0.59	0.59	0.59
Installation height without bias (H_{sk})	10.51	12.87	15.24	19.17	23.11	27.05
Arc projection (M_l)	7.99	9.17	10.35	12.32	14.29	16.26
Bend length (L_b)	18.62	22.32	26.02	32.20	38.39	44.57



MP 41.2 - PowerLine 2nd generation

Chain bracket

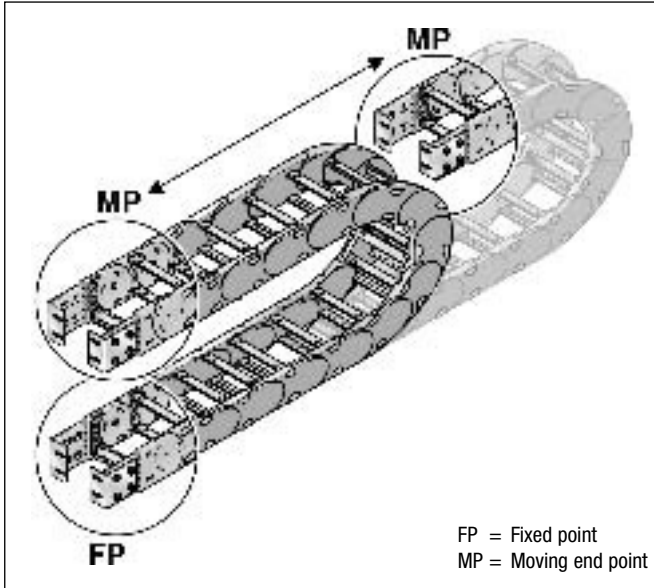

Flexible chain bracket

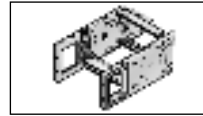

Chain bracket angle

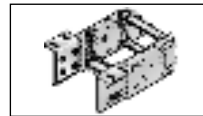

Top/Outside



Front/Outside

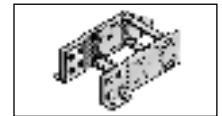

Bottom/Outside

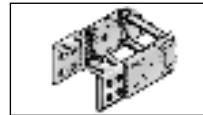

Top/Inside

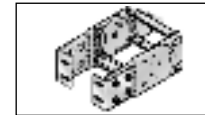

Front/Inside

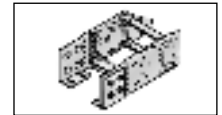

Bottom/Inside

Flexible chain bracket

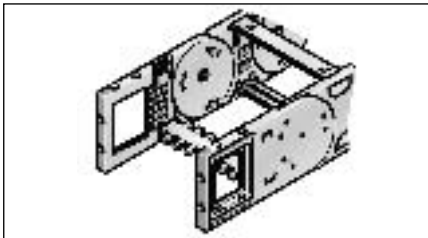

KA 41...

Type	Order no.	Version	Pack qty.
KA 41-FB	0411000054	with bushing	1
KA 41-FG	0411000055	with thread	1

This chain bracket offers universal connection options (top, bottom and front) and is attached to the ends of the chain like a side link. This allows the chain to move right up to the bracket. Each chain requires one male and one female bracket. M6 screws are used to secure the brackets in place. Extrusion-coated metal bushings with either a through-hole (-FB) or a threaded hole (-FG) ensure the permanent, high-strength transmission of even extreme forces onto the cable drag chain.

Chain bracket angle

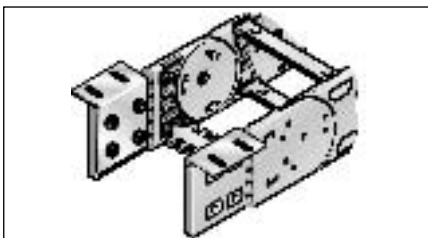

KA 41

Type	Order no.	Pack qty.
KA 41	0410000051	1

There are several options regarding the chain bracket. The fixed-point bracket (inside/bottom) and the moving end bracket (inside/top) are supplied as standard. However, any other combination can be supplied upon request. The chain bracket is fastened at the end like a side link. This enables the chain to move right up to the bracket. Each chain requires one male and one female bracket. The brackets should be fastened with M6 screws.

Flexible chain bracket

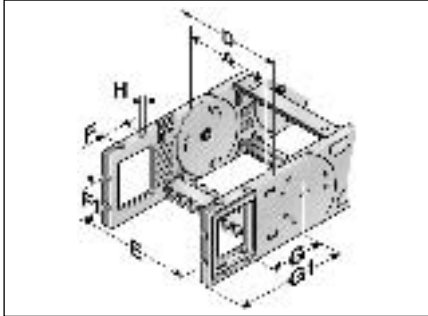

Flexible with through-hole

Type	A inch	D inch	E inch	F inch	F1 inch	G inch	G1 inch	H Ø inch
KA 41-FB	1.77	3.11	2.56	0.89	0.87	3.11	4.72	0.26
KA 41-FB	2.44	3.78	3.23	0.89	0.87	3.11	4.72	0.26
KA 41-FB	2.80	4.13	3.58	0.89	0.87	3.11	4.72	0.26
KA 41-FB	3.31	4.65	4.09	0.89	0.87	3.11	4.72	0.26
KA 41-FB	3.78	5.12	4.57	0.89	0.87	3.11	4.72	0.26
KA 41-FB	4.21	5.55	5.00	0.89	0.87	3.11	4.72	0.26
KA 41-FB	4.76	6.10	5.55	0.89	0.87	3.11	4.72	0.26
KA 41-FB	5.24	6.57	6.06	0.89	0.87	3.11	4.72	0.26
KA 41-FB	5.67	7.01	6.46	0.89	0.87	3.11	4.72	0.26
KA 41-FB	5.75	7.09	6.54	0.89	0.87	3.11	4.72	0.26
KA 41-FB	6.22	7.56	7.01	0.89	0.87	3.11	4.72	0.26
KA 41-FB	6.73	8.07	7.52	0.89	0.87	3.11	4.72	0.26
KA 41-FB	7.17	8.50	7.95	0.89	0.87	3.11	4.72	0.26
KA 41-FB	7.72	9.06	8.50	0.89	0.87	3.11	4.72	0.26
KA 41-FB	8.66	10.00	9.45	0.89	0.87	3.11	4.72	0.26
KA 41-FB	9.69	11.02	10.47	0.89	0.87	3.11	4.72	0.26
KA 41-FB	11.65	12.99	12.44	0.89	0.87	3.11	4.72	0.26
KA 41-FB	13.62	14.96	14.41	0.89	0.87	3.11	4.72	0.26
KA 41-FB	15.59	16.93	16.38	0.89	0.87	3.11	4.72	0.26
KA 41-FB	17.56	18.90	18.35	0.89	0.87	3.11	4.72	0.26
KA 41-FB	19.53	20.87	20.31	0.89	0.87	3.11	4.72	0.26
KA 41-FB	21.50	22.83	22.28	0.89	0.87	3.11	4.72	0.26
KA 41-FB	variable	A+1.34	A+0.79	0.89	0.87	3.11	4.72	0.26

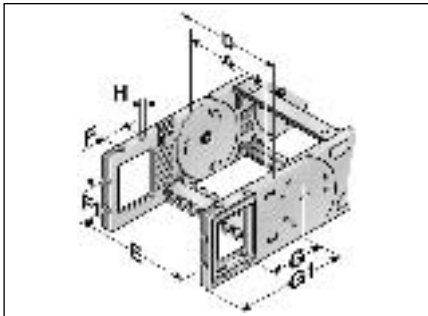

Flexible with threaded bushing

Type	A inch	D inch	E inch	F inch	F1 inch	G inch	G1 inch	H
KA 41-FG	1.77	3.11	2.56	0.89	0.87	3.11	4.72	M6
KA 41-FG	2.44	3.78	3.23	0.89	0.87	3.11	4.72	M6
KA 41-FG	2.80	4.13	3.58	0.89	0.87	3.11	4.72	M6
KA 41-FG	3.31	4.65	4.09	0.89	0.87	3.11	4.72	M6
KA 41-FG	3.78	5.12	4.57	0.89	0.87	3.11	4.72	M6
KA 41-FG	4.21	5.55	5.00	0.89	0.87	3.11	4.72	M6
KA 41-FG	4.76	6.10	5.55	0.89	0.87	3.11	4.72	M6
KA 41-FG	5.24	6.57	6.06	0.89	0.87	3.11	4.72	M6
KA 41-FG	5.67	7.01	6.46	0.89	0.87	3.11	4.72	M6
KA 41-FG	5.75	7.09	6.54	0.89	0.87	3.11	4.72	M6
KA 41-FG	6.22	7.56	7.01	0.89	0.87	3.11	4.72	M6
KA 41-FG	6.73	8.07	7.52	0.89	0.87	3.11	4.72	M6
KA 41-FG	7.17	8.50	7.95	0.89	0.87	3.11	4.72	M6
KA 41-FG	7.72	9.06	8.50	0.89	0.87	3.11	4.72	M6
KA 41-FG	8.66	10.00	9.45	0.89	0.87	3.11	4.72	M6
KA 41-FG	9.69	11.02	10.47	0.89	0.87	3.11	4.72	M6
KA 41-FG	11.65	12.99	12.44	0.89	0.87	3.11	4.72	M6
KA 41-FG	13.62	14.96	14.41	0.89	0.87	3.11	4.72	M6
KA 41-FG	15.59	16.93	16.38	0.89	0.87	3.11	4.72	M6
KA 41-FG	17.56	18.90	18.35	0.89	0.87	3.11	4.72	M6
KA 41-FG	19.53	20.87	20.31	0.89	0.87	3.11	4.72	M6
KA 41-FG	21.50	22.83	22.28	0.89	0.87	3.11	4.72	M6
KA 41-FG	variable	A+1.34	A+0.79	0.89	0.87	3.11	4.72	M6



MP 41.2 - PowerLine 2nd generation

Chain bracket angle

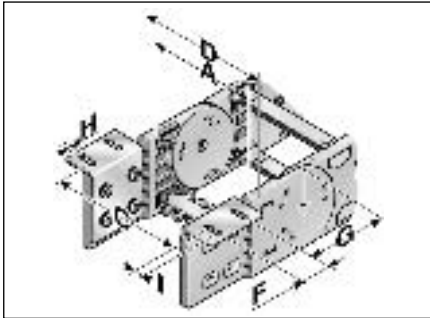

Bottom and top/outside

Type	A inch	C inch	D inch	F inch	G inch	H Ø inch	I inch
KA 41	1.77	3.13	3.03	1.26	3.11	0.26	0.55
KA 41	2.44	3.80	3.70	1.26	3.11	0.26	0.55
KA 41	2.80	4.15	4.06	1.26	3.11	0.26	0.55
KA 41	3.31	4.67	4.57	1.26	3.11	0.26	0.55
KA 41	3.78	5.14	5.04	1.26	3.11	0.26	0.55
KA 41	4.21	5.57	5.47	1.26	3.11	0.26	0.55
KA 41	4.76	6.12	6.02	1.26	3.11	0.26	0.55
KA 41	5.24	6.59	6.5	1.26	3.11	0.26	0.55
KA 41	5.67	7.03	6.93	1.26	3.11	0.26	0.55
KA 41	5.75	7.11	7.01	1.26	3.11	0.26	0.55
KA 41	6.22	7.58	7.48	1.26	3.11	0.26	0.55
KA 41	6.73	8.09	7.99	1.26	3.11	0.26	0.55
KA 41	7.17	8.52	8.39	1.26	3.11	0.26	0.55
KA 41	7.72	9.07	8.98	1.26	3.11	0.26	0.55
KA 41	8.66	10.02	9.92	1.26	3.11	0.26	0.55
KA 41	9.69	11.04	10.94	1.26	3.11	0.26	0.55
KA 41	11.65	13.01	12.91	1.26	3.11	0.26	0.55
KA 41	13.62	14.98	14.88	1.26	3.11	0.26	0.55
KA 41	15.59	16.95	16.85	1.26	3.11	0.26	0.55
KA 41	17.56	18.92	18.82	1.26	3.11	0.26	0.55
KA 41	19.53	20.89	20.79	1.26	3.11	0.26	0.55
KA 41	21.50	22.85	22.76	1.26	3.11	0.26	0.55
KA 41	variable	A+1.36	A+1.26	1.26	3.11	0.26	0.55

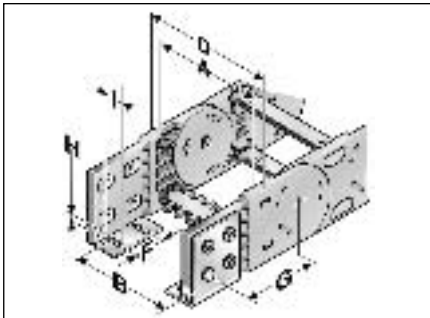

Bottom and top/inside

Type	A inch	B inch	D inch	F inch	G inch	H Ø inch	I inch
KA 41	1.77	1.67	3.03	1.26	3.11	0.26	0.55
KA 41	2.44	2.34	3.70	1.26	3.11	0.26	0.55
KA 41	2.80	2.70	4.06	1.26	3.11	0.26	0.55
KA 41	3.31	3.21	4.57	1.26	3.11	0.26	0.55
KA 41	3.78	3.68	5.04	1.26	3.11	0.26	0.55
KA 41	4.21	4.11	5.47	1.26	3.11	0.26	0.55
KA 41	4.76	4.67	6.02	1.26	3.11	0.26	0.55
KA 41	5.24	5.14	6.5	1.26	3.11	0.26	0.55
KA 41	5.67	5.57	6.93	1.26	3.11	0.26	0.55
KA 41	5.75	5.65	7.01	1.26	3.11	0.26	0.55
KA 41	6.22	6.12	7.48	1.26	3.11	0.26	0.55
KA 41	6.73	6.63	7.99	1.26	3.11	0.26	0.55
KA 41	7.17	7.07	8.39	1.26	3.11	0.26	0.55
KA 41	7.72	7.62	8.98	1.26	3.11	0.26	0.55
KA 41	8.66	8.56	9.92	1.26	3.11	0.26	0.55
KA 41	9.69	9.59	10.94	1.26	3.11	0.26	0.55
KA 41	11.65	11.56	12.91	1.26	3.11	0.26	0.55
KA 41	13.62	13.52	14.88	1.26	3.11	0.26	0.55
KA 41	15.59	15.49	16.85	1.26	3.11	0.26	0.55
KA 41	17.56	17.46	18.82	1.26	3.11	0.26	0.55
KA 41	19.53	19.43	20.79	1.26	3.11	0.26	0.55
KA 41	21.50	21.40	22.76	1.26	3.11	0.26	0.55
KA 41	variable	A-0.10	A+1.26	1.26	3.11	0.26	0.55

Chain bracket angle

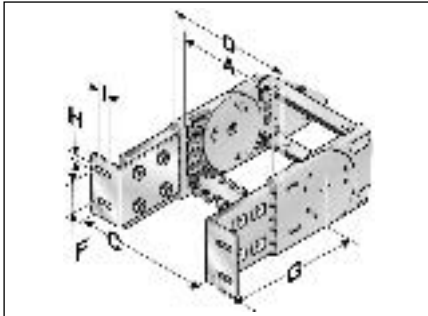

Front/Outside

Type	A inch	C inch	D inch	F inch	G inch	H Ø inch	I inch
KA 41	1.77	3.13	3.03	1.26	4.95	0.26	0.55
KA 41	2.44	3.80	3.70	1.26	4.95	0.26	0.55
KA 41	2.80	4.15	4.06	1.26	4.95	0.26	0.55
KA 41	3.31	4.67	4.57	1.26	4.95	0.26	0.55
KA 41	3.78	5.14	5.04	1.26	4.95	0.26	0.55
KA 41	4.21	5.57	5.47	1.26	4.95	0.26	0.55
KA 41	4.76	6.12	6.02	1.26	4.95	0.26	0.55
KA 41	5.24	6.59	6.5	1.26	4.95	0.26	0.55
KA 41	5.67	7.03	6.93	1.26	4.95	0.26	0.55
KA 41	5.75	7.11	7.01	1.26	4.95	0.26	0.55
KA 41	6.22	7.58	7.48	1.26	4.95	0.26	0.55
KA 41	6.73	8.09	7.99	1.26	4.95	0.26	0.55
KA 41	7.17	8.52	8.39	1.26	4.95	0.26	0.55
KA 41	7.72	9.07	8.98	1.26	4.95	0.26	0.55
KA 41	8.66	10.02	9.92	1.26	4.95	0.26	0.55
KA 41	9.69	11.04	10.94	1.26	4.95	0.26	0.55
KA 41	11.65	13.01	12.91	1.26	4.95	0.26	0.55
KA 41	13.62	14.98	14.88	1.26	4.95	0.26	0.55
KA 41	15.59	16.95	16.85	1.26	4.95	0.26	0.55
KA 41	17.56	18.92	18.82	1.26	4.95	0.26	0.55
KA 41	19.53	20.89	20.79	1.26	4.95	0.26	0.55
KA 41	21.50	22.85	22.76	1.26	4.95	0.26	0.55
KA 41	variable	A+1.36	A+1.26	1.26	4.95	0.26	0.55

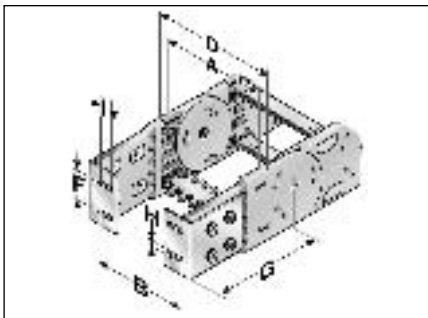

Front/Inside

Type	A inch	B inch	D inch	F inch	G inch	H Ø inch	I inch
KA 41	1.77	1.67	3.03	1.26	4.95	0.26	0.55
KA 41	2.44	2.34	3.70	1.26	4.95	0.26	0.55
KA 41	2.80	2.70	4.06	1.26	4.95	0.26	0.55
KA 41	3.31	3.21	4.57	1.26	4.95	0.26	0.55
KA 41	3.78	3.68	5.04	1.26	4.95	0.26	0.55
KA 41	4.21	4.11	5.47	1.26	4.95	0.26	0.55
KA 41	4.76	4.67	6.02	1.26	4.95	0.26	0.55
KA 41	5.24	5.14	6.5	1.26	4.95	0.26	0.55
KA 41	5.67	5.57	6.93	1.26	4.95	0.26	0.55
KA 41	5.75	5.65	7.01	1.26	4.95	0.26	0.55
KA 41	6.22	6.12	7.48	1.26	4.95	0.26	0.55
KA 41	6.73	6.63	7.99	1.26	4.95	0.26	0.55
KA 41	7.17	7.07	8.39	1.26	4.95	0.26	0.55
KA 41	7.72	7.62	8.98	1.26	4.95	0.26	0.55
KA 41	8.66	8.56	9.92	1.26	4.95	0.26	0.55
KA 41	9.69	9.59	10.94	1.26	4.95	0.26	0.55
KA 41	11.65	11.56	12.91	1.26	4.95	0.26	0.55
KA 41	13.62	13.52	14.88	1.26	4.95	0.26	0.55
KA 41	15.59	15.49	16.85	1.26	4.95	0.26	0.55
KA 41	17.56	17.46	18.82	1.26	4.95	0.26	0.55
KA 41	19.53	19.43	20.79	1.26	4.95	0.26	0.55
KA 41	21.50	21.40	22.76	1.26	4.95	0.26	0.55
KA 41	variable	A-0.10	A+1.26	1.26	4.95	0.26	0.55



Assembly instruction flexible chain bracket

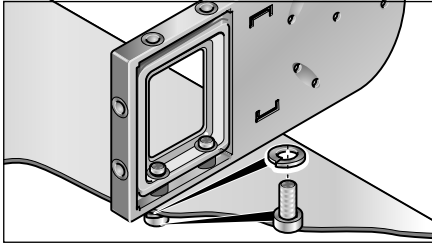

Chain bracket with threaded bushing

Brass bushings guarantee long-lasting fastening without cold flow in the plastic.

Version KA-FB:

Integrated through-hole fastened down using screw and nut.

Version KA-FG:

Built-in threads allow for quick and easy on-site mounting, since a screw, including a retaining washer where necessary, is sufficient.

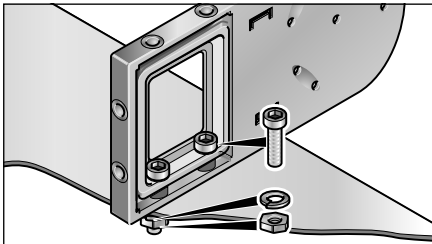

Chain bracket with bushing

Separator

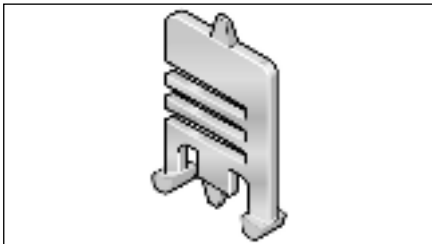

Separator

Type	Order no.	Designation	Pitch inch	Pack qty.
TR 41.1	041200009200	TR 41.1 Separator	0.22	1

We recommend that separators be used if multiple round cables or conduits with differing diameters are to be installed. An offset configuration of the separators is advisable.

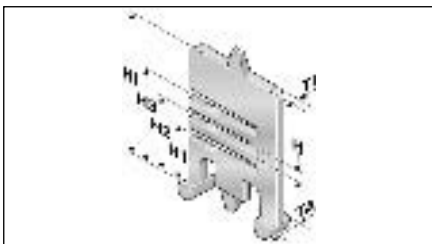

Separator

Type	T1 inch	H inch	H1 inch	H2 inch	H3 inch	H1 inch
TR 41.1	0.14	0.16	0.71	0.98	1.22	1.65

H-shaped shelf unit

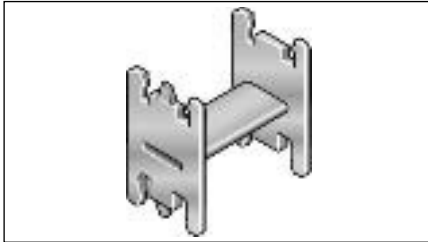

H-shaped shelf unit

Type	Order no.	Designation	Pitch inch	Pack qty.
RE 36/11	100000361112	RE 36/11 H-shaped shelf unit	0.22	1
RE 59/18	100000591812	RE 59/18 H-shaped shelf unit	0.22	1
RE 81/11	100000811112	RE 81/11 H-shaped shelf unit	0.22	1

Insert to obtain additional levels in pre-defined distances.

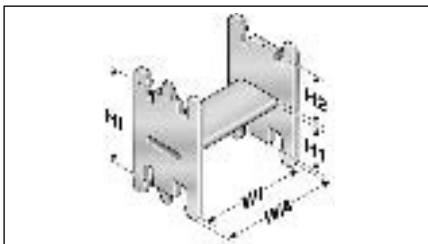

H-shaped shelf unit

Type	WA inch	WI inch	H1 inch	H2 inch	HI inch
RE 36/11	1.67	1.44	1.03	0.45	1.65
RE 59/18	2.56	2.32	0.74	0.74	1.65
RE 81/11	3.44	3.21	1.03	0.45	1.65

Shelving system

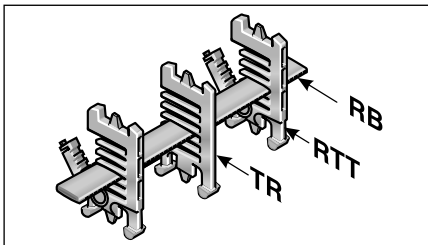

Shelving system

Type	Order no.	Designation	Width inch	Pitch inch	Pack qty.
RB 028-5	100000002800	RB 028-5 Shelf	1.10	0.22	1
RB 056-5	100000005600	RB 056-5 Shelf	2.20	0.22	1
RB 084-5	100000008400	RB 084-5 Shelf	3.31	0.22	1
RB 112-5	100000011200	RB 112-5 Shelf	4.41	0.22	1
RB 140-5	100000014000	RB 140-5 Shelf	5.51	0.22	1
RB 168-5	100000016800	RB 168-5 Shelf	6.61	0.22	1
RB 196-5	100000019600	RB 196-5 Shelf	7.72	0.22	1
RTT 41	100090412000	RTT 41 Shelf support, divisible		0.22	1

In connection with at least two shelf supports (RTT) the shelf becomes a shelving system. The additional levels prevent cables from criss-crossing and therefore destroying each other, while also avoiding excessive friction. Pre-assembly is not necessary as the shelving system and cabling can be assembled quickly and easily on site.

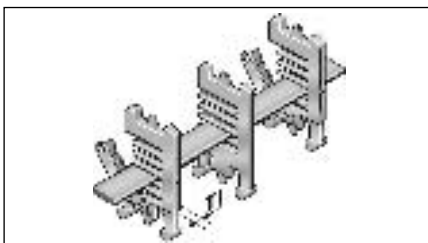

Shelving system

Type	T1 inch
RTT 41	0.28



MP 41.2 - Accessories

Crossbar connector

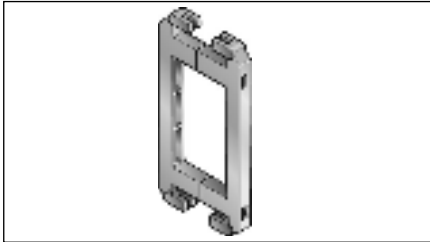

Crossbar connector

Type	Order no.	Designation	Pack qty.
RSV 41	041000009600	RSV 41 Crossbar connector	1
RSV 41 Alu	041000009800	RSV 41 Crossbar connector for aluminum crossbridges	1

For frame bridges wider than 9.69 in (246 mm), we recommend the use of crossbar connectors. These prevent deformation to the frame bridge under large amounts of additional weight of the chain assembly.

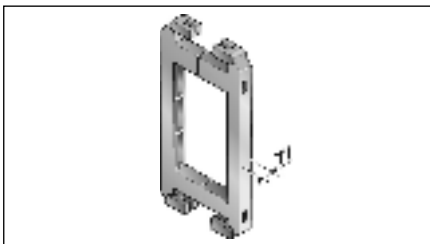

Type	T1 inch
RSV 41	0.30
RSV 41 Alu	0.30

Crossbar strain relief plate RS-ZL

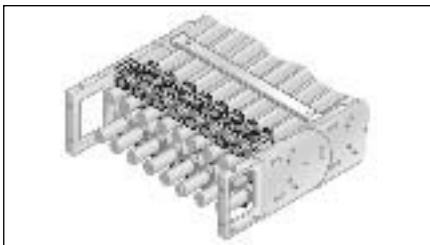

Crossbar strain relief plate RS-ZL

Type	Order no.	For internal width inch	Pack qty.
RS-ZL 045-5	052004500010	1.77	1
RS-ZL 062-5	052006200010	2.44	1
RS-ZL 071-5	052007100010	2.80	1
RS-ZL 084-5	052008400010	3.31	1
RS-ZL 096-5	052009600010	3.78	1
RS-ZL 107-5	052010700010	4.21	1
RS-ZL 121-5	052012100010	4.76	1
RS-ZL 133-5	052013300010	5.24	1
RS-ZL 5.67/5.75-5	052014400010	5.67/5.75	1
RS-ZL 158-5	052015800010	6.22	1
RS-ZL 171-5	052017100010	6.73	1
RS-ZL 182-5	052018200010	7.17	1
RS-ZL 196-5	052019600010	7.72	1
RS-ZL 220-5	052022000010	8.66	1
RS-ZL 246-5	052024600010	9.69	1

Fixed integrated frame bridge strain relief plates in the chain brackets. Tailored to all frame bridge widths up to 9.69 in (246 mm). May be assembled on the inside and outside flexure curves at both chain endings.

Strain relief type BAK

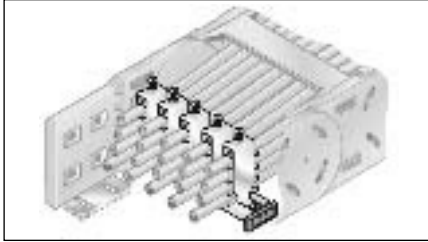

Strain relief with hooped clamp

Type	Order no.	Designation	Ø inch	Number of seats	Pack qty.
C-rail	81661610	C-profile rail			1
BA 12	81661036	BA 12 Hooped clamp	0.35–0.47	1	1
BAK 14	81661002	BAK 14 Hooped clamp	0.24–0.55	1	1
BAK 18	81661004	BAK 18 Hooped clamp	0.55–0.71	1	1
BAK 22	81661006	BAK 22 Hooped clamp	0.71–0.87	1	1
BAK 26	81661008	BAK 26 Hooped clamp	0.87–1.02	1	1
BAK 30	81661010	BAK 30 Hooped clamp	1.02–1.18	1	1
BAK 34	81661000	BAK 34 Hooped clamp	1.18–1.34	1	1
BAK 38	81661044	BAK 38 Hooped clamp	1.34–1.50	1	1
BAK 42	81661032	BAK 42 Hooped clamp	1.50–1.65	1	1
BAK 46	81661050	BAK 46 Hooped clamp	1.65–1.81	1	1
BA 12/2	81661038	BA 12/2 Hooped clamp	0.35–0.47	2	1
BAK 14/2	81661012	BAK 14/2 Hooped clamp	0.39–0.55	2	1
BAK 18/2	81661014	BAK 18/2 Hooped clamp	0.55–0.71	2	1
BAK 22/2	81661016	BAK 22/2 Hooped clamp	0.71–0.87	2	1
BAK 26/2	81661018	BAK 26/2 Hooped clamp	0.87–1.02	2	1
BAK 30/2	81661048	BAK 30/2 Hooped clamp	1.02–1.18	2	1
BAK 34/2	81661044	BAK 34/2 Hooped clamp	1.18–1.34	2	1
BAK 38/2	81661046	BAK 38/2 Hooped clamp	1.34–1.50	2	1
BAK 42/2	81661034	BAK 42/2 Hooped clamp	1.50–1.65	2	1
BAK 12/3	81661020	BAK 12/3 Hooped clamp	0.35–0.47	3	1
BAK 14/3	81661022	BAK 14/3 Hooped clamp	0.47–0.55	3	1
BAK 16/3	81661024	BAK 16/3 Hooped clamp	0.55–0.63	3	1
BAK 18/3	81661026	BAK 18/3 Hooped clamp	0.63–0.71	3	1
BAK 20/3	81661028	BAK 20/3 Hooped clamp	0.71–0.79	3	1
BAK 22/3	81661030	BAK 22/3 Hooped clamp	0.79–0.87	3	1

Fixed integrated strain relief in the chain connections. Available in all widths (also individual widths for aluminum frame ridges). May be assembled on the inside and outside flexure curves at both chain endings. Chain content is secured through hooped clamps that are available in different sizes. Material: Galvanized steel.

When ordering please indicate the type of chain and internal width.

Reverse radius

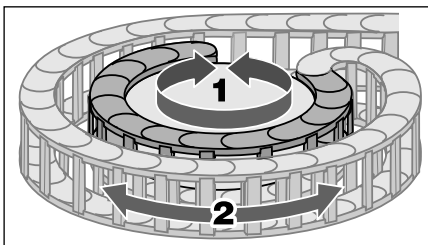

Rotating movement

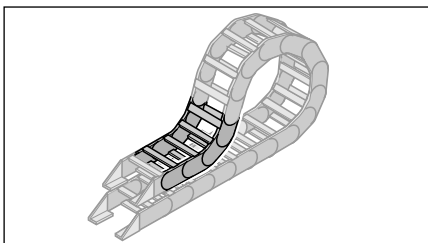

lowered chain bracket

Type	Order no.	Radius inch	Reverse radius inch	Pack qty.
SR 41.2 (RÜ200/R125)	41200009060	4.92	7.87	1
SR 41.2 (RÜ200/R160)	41200012060	6.30	7.87	1
SR 41.2 (RÜ200/R175)	41200015060	6.89	7.87	1
SR 41.2 (RÜ200/R200)	41200020060	7.87	7.87	1
SR 41.2 (RÜ200/R250)	41200025060	9.84	7.87	1
SR 41.2 (RÜ200/R300)	41200030060	11.81	7.87	1
SR 41.2 (RÜ200/R350)	41200035060	13.78	7.87	1

Side links with radius forward (R) and radius backward (Rü) allow for movement in two directions. This is intended for rotating movements and lowered chain brackets.



MP 41.2 - Accessories

Assembly Disassembly

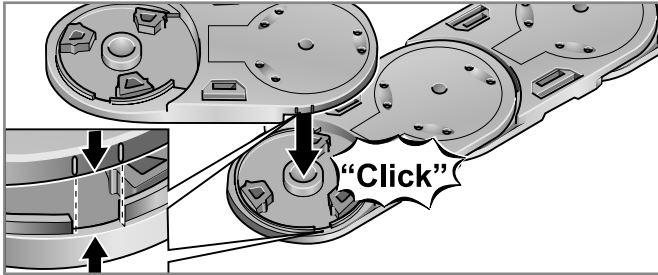

Step 1

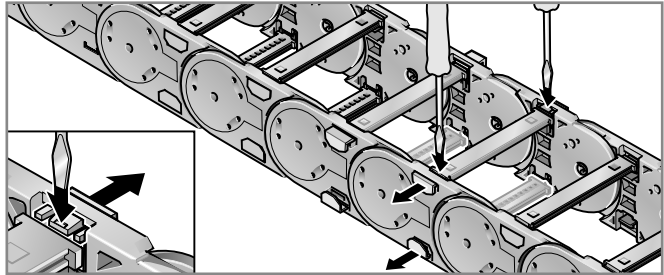

Step 1

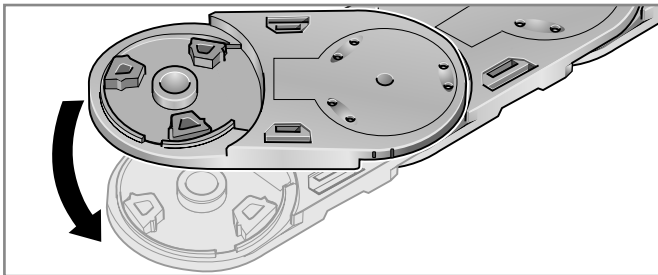

Step 2

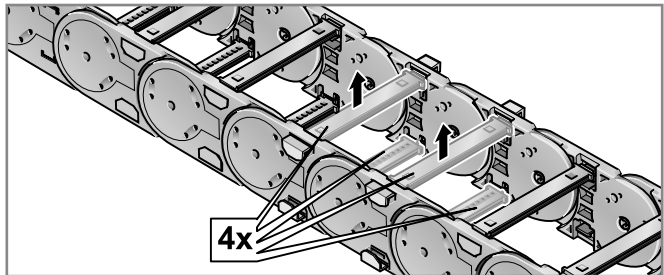

Step 2

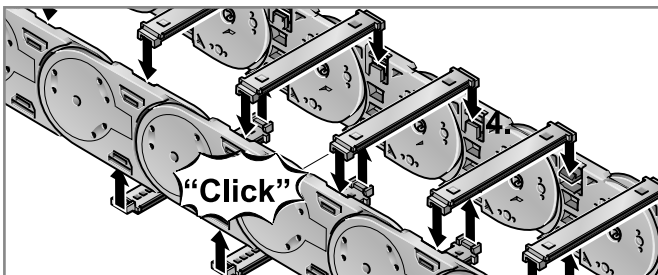

Step 3

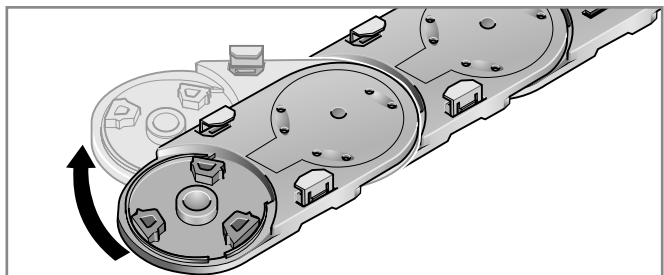

Step 3

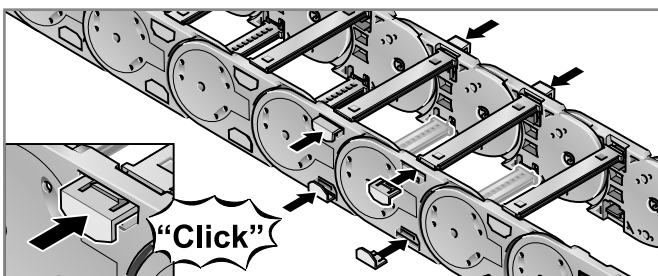

Step 4

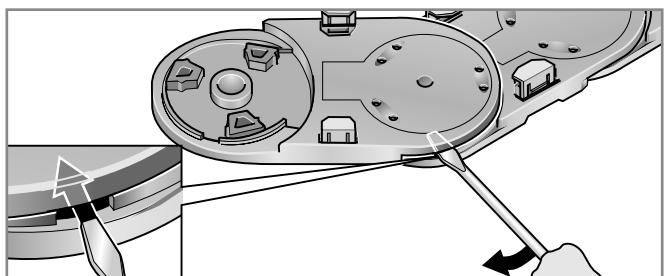

Step 4

Cable drag chain systems

PowerLine

MP 52.1

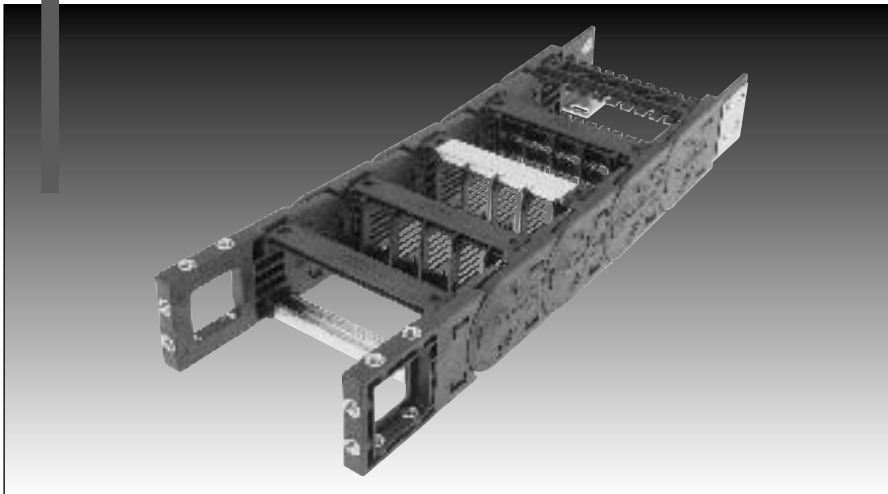



Order variants

Style (order code)									
Configuration (order code) *= standard									
Radius (order code) <small>The radii can be combined with any internal width</small>									
in inch									
Internal width (order code)									
in inch									
Outside width									
in inch									
MP52.1 045	3.03	1.77	045						
MP52.1 062	3.70	2.44	062						
MP52.1 071	4.06	2.80	071						
MP52.1 084	4.57	3.31	084						
MP52.1 096	5.04	3.78	096						
MP52.1 107	5.47	4.21	107						
MP52.1 121	6.02	4.76	121						
MP52.1 133	6.65	5.24	133						
MP52.1 144	6.93	5.67	144						
MP52.1 146	7.01	5.75	146						
MP52.1 158	7.64	6.22	158						
MP52.1 171	7.99	6.73	171						
MP52.1 182	8.43	7.17	182						
MP52.1 196	8.98	7.72	196						
MP52.1 246	10.94	9.69	246						0
MP52.1 296	12.91	11.65	296						1
MP52.1 346	14.88	13.62	346						2*
MP52.1 396	16.85	15.59	396	3.94	100				3*
MP52.1 446	18.82	17.56	446	5.91	150				4
MP52.1 496	20.79	19.53	496	7.87	200				5
MP52.1 546	22.76	21.50	546	9.84	250				6
MP52.1 xxx	inside	>3.15		11.81	300				7
	+ 1.26	-23.62	Alu	13.78	350				9
									0
									9

Order-Number:

Configuration:

- 0 PA crossbar every link; w/bias
- 1 PA crossbar every link; w/o bias
- 2* PA crossbar EOL; w/bias
- 3* PA crossbar EOL; w/o bias
- 4 AL crossbar every link; w/bias
- 5 AL crossbar every link; w/o bias
- 6 AL crossbar EOL; w/bias
- 7 AL crossbar EOL; w/o bias
- 9 Custom version

Style:

- 0 Standard (PA/black)
- 9 Custom version

Sample order:
0521 045 100 0000

Internal width = 1.77 in (45 mm)
Radius = 3.94 in (100 mm)
Configuration = 0
Style = 0

Ideal operating conditions:

- Extreme accelerations
- Extreme speeds
- Extreme self-supporting lengths
- Very high additional loads
- Both sides must be opened
- Aluminum frame bridge in variable lengths
- Flexible internal separation
- Rotated 90° unsupported
- Rotated 90° horizontal
- Version with/without bias

Alternative chain type:

- MP 65 G closed series
- MP 66 easier to use
- MP 52.2 simpler assembly

Features

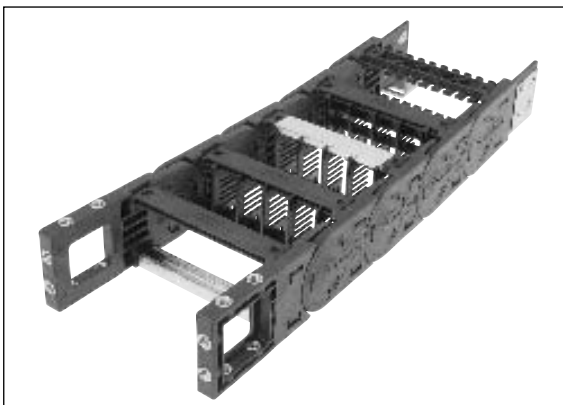

Chain bracket, can be fastened on three sides



Crossbar strain relief can be integrated into chain bracket



Radii with or without bias (RV/RK)



Aluminum frame bridges with integrated lock grid in variable lengths



Chain bracket with variably positionable metal angle



Crossbar/cover can be removed from inside and outside flexure curve



Reverse radius combinations



Foldable shelf system for reliable cable guidance

Technical data

Chain link dimensions (inch) (mm)

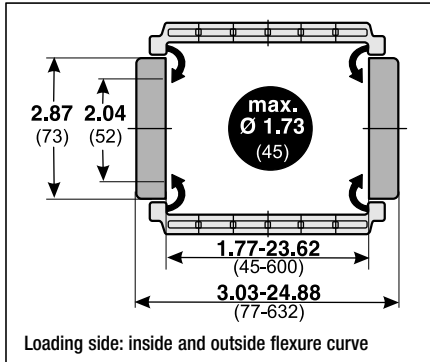

Material characteristics standard (PA/black)

Operating temperature:	-22 to 248° F
Gliding friction factor:	0.30
Static friction factor:	0.45
Fire classification:	Based on UL94 HB
Other material properties on request	

Technical specifications

Travel distance, gliding, L_g :	492.13 ft
Travel distance, self-supporting, L_s :	see diagram
Travel distance, vertical, hanging, L_{vs} :	328.08 ft
Travel distance, vertical, upright, L_{vs} :	19.69 ft
Rotated 90°, self-supporting, L_{90r} :	9.84 ft
Speed, gliding, V_g :	16.40 ft/s
Speed, self-supporting, V_s :	65.62 ft/s
Acceleration, gliding, a_g :	82.02 ft/s ²
Acceleration, self-supporting, a_s :	98.43 ft/s ²

Self-supporting length

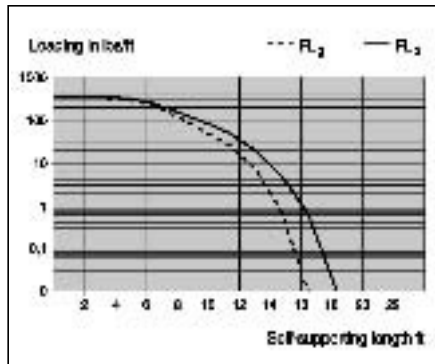
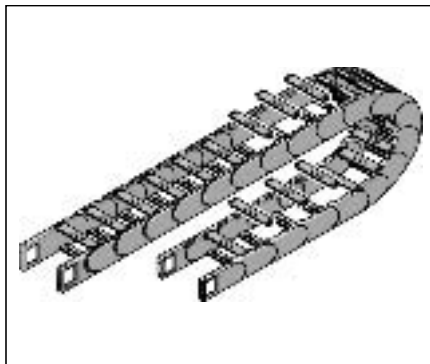

FL_g:
Ideal installation situation for high stresses at the limit of the max. travel parameters. In this range the chain upper run is still biased, straight or has a max. sag of 0.39 – 1.97 in (10 – 50 mm) depending on the type of chain.

FL_b:
Satisfactory installation position for many applications working in the lower to middle range of the max. travel parameters. Depending on the chain type, the sag of the chain upper run is >0.39 – 1.97 in (>10 – 50 mm) but certainly less than the max. sag.

If the sag is greater than FL_b, the arrangement is unsuitable and should be avoided. Please choose a more stable Murrplastik cable drag chain.

Determining the chain length

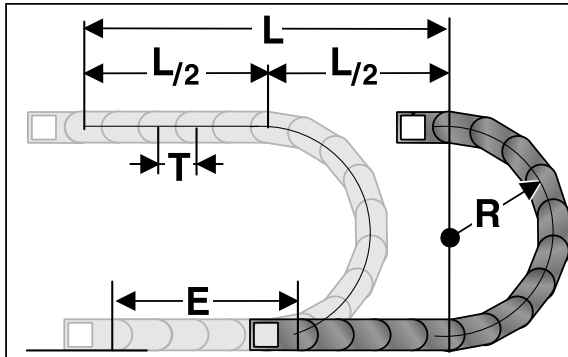

L = Travel distance
R = Radius
T = Pitch
E = Distance between entry point and middle of travel distance

Determining the chain length

$$\text{Length} = \frac{L}{2} + \pi \times R + E$$

≈ 1 ft(m) chain = 4(11) links each 3.58 in (91 mm)

The fixed point of the cable drag chain should be connected in the middle of the travel distance. This arrangement gives the shortest connection between the fixed point and the moving point and thus the most efficient chain length.

Installation dimensions (in inch)

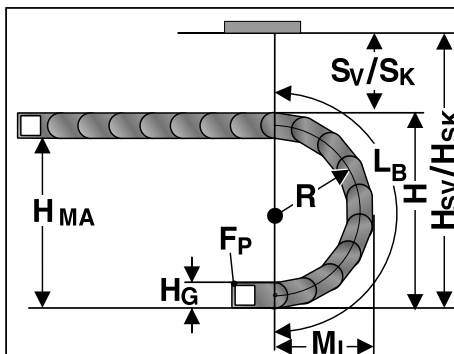

Radius R	3.94	5.91	7.87	9.84	11.81	13.78
Outside height of chain link (H_o)	2.91	2.91	2.91	2.91	2.91	2.91
Height of bend (H)	11.97	15.91	19.84	23.78	27.72	31.65
Height of moving end connection (H_{ma})	9.06	12.99	16.93	20.87	24.80	28.74
Safety margin with bias (S_v)	1.81	1.81	1.81	1.81	1.81	1.81
Installation height with bias (H_{sv})	13.78	17.72	21.65	25.59	29.53	33.46
Safety margin without bias (S_k)	0.63	0.63	0.63	0.63	0.63	0.63
Installation height without bias (H_{sk})	12.60	16.54	20.47	24.41	28.35	32.28
Arc projection (M_l)	9.57	11.54	13.50	15.47	17.44	19.41
Bend length (L_b)	22.36	28.54	34.72	40.91	47.09	53.27



Chain bracket

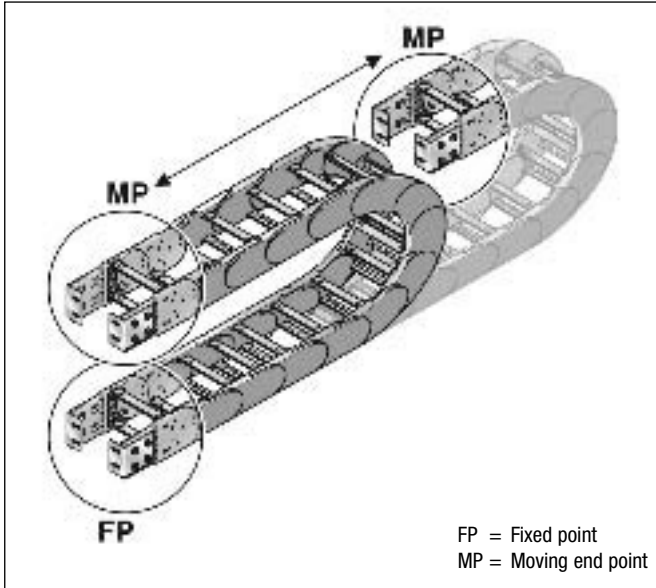

Flexible chain bracket

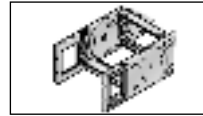

Flexible

Chain bracket angle

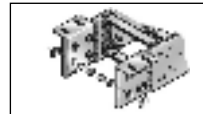

Top/Outside

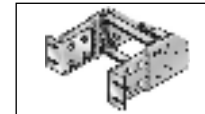

Front/Outside

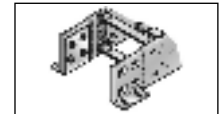

Bottom/Outside

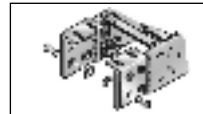

Top/Inside

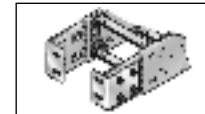

Front/Inside

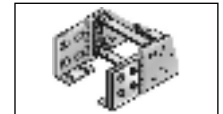

Bottom/Inside

Flexible chain bracket

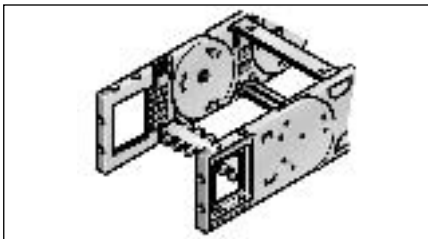

KA 52.1...

Type	Order no.	Version	Pack qty.
KA 52.1-FB Female end	0521000056	with bushing	1
KA 52.1-FB Male end	0521000057	with bushing	1
KA 52.1-FG Female end	0521000058	with thread	1
KA 52.1-FG Male end	0521000059	with thread	1

This chain bracket offers universal connection options (top, bottom and front) and is attached to the ends of the chain like a side link. This allows the chain to move right up to the bracket. Each chain requires one male and one female bracket. Use M8 screws for connecting. Extrusion-coated metal bushings with either a through-hole (-FB) or a threaded hole (-FG) ensure the permanent, high-strength transmission of even extreme forces onto the cable drag chain.

Chain bracket angle

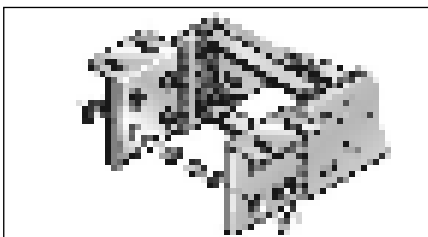

KA 52.1

Type	Order no.	Pack qty.
KA 52.1 Female end	0521000050	1
KA 52.1 Male end	0521000051	1

There are several options regarding the chain bracket. The fixed-point bracket (inside/bottom) and the moving end bracket (inside/top) are supplied as standard. However, any other combination can be supplied upon request. The chain bracket is fastened at the end like a side link. This enables the chain to move right up to the bracket. Each chain requires one male and one female bracket. The brackets should be fastened with M6 screws.

Flexible chain bracket

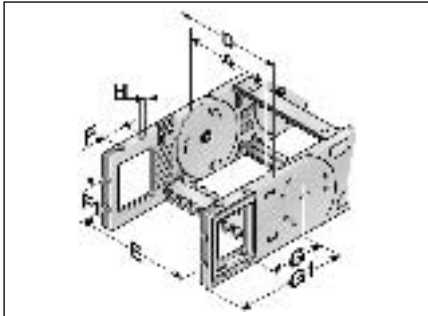

Flexible with through-hole

Type	A inch	D inch	E inch	F inch	F1 inch	G inch	G1 inch	H Ø inch
KA 52.1-FB	1.77	3.19	2.40	1.38	1.18	3.50	5.67	0.33
KA 52.1-FB	2.44	3.86	3.07	1.38	1.18	3.50	5.67	0.33
KA 52.1-FB	2.80	4.21	3.43	1.38	1.18	3.50	5.67	0.33
KA 52.1-FB	3.31	4.72	3.94	1.38	1.18	3.50	5.67	0.33
KA 52.1-FB	3.78	5.20	4.41	1.38	1.18	3.50	5.67	0.33
KA 52.1-FB	4.21	5.63	4.84	1.38	1.18	3.50	5.67	0.33
KA 52.1-FB	4.76	6.18	5.39	1.38	1.18	3.50	5.67	0.33
KA 52.1-FB	5.24	6.65	5.87	1.38	1.18	3.50	5.67	0.33
KA 52.1-FB	5.67	7.09	6.30	1.38	1.18	3.50	5.67	0.33
KA 52.1-FB	5.75	7.17	6.38	1.38	1.18	3.50	5.67	0.33
KA 52.1-FB	6.22	7.64	6.85	1.38	1.18	3.50	5.67	0.33
KA 52.1-FB	6.73	8.15	7.36	1.38	1.18	3.50	5.67	0.33
KA 52.1-FB	7.17	8.58	7.80	1.38	1.18	3.50	5.67	0.33
KA 52.1-FB	7.72	9.13	8.35	1.38	1.18	3.50	5.67	0.33
KA 52.1-FB	8.66	10.08	9.29	1.38	1.18	3.50	5.67	0.33
KA 52.1-FB	9.69	11.10	10.31	1.38	1.18	3.50	5.67	0.33
KA 52.1-FB	11.65	13.07	12.28	1.38	1.18	3.50	5.67	0.33
KA 52.1-FB	13.62	15.04	14.25	1.38	1.18	3.50	5.67	0.33
KA 52.1-FB	15.59	17.01	16.22	1.38	1.18	3.50	5.67	0.33
KA 52.1-FB	17.56	18.98	18.19	1.38	1.18	3.50	5.67	0.33
KA 52.1-FB	19.53	20.94	20.16	1.38	1.18	3.50	5.67	0.33
KA 52.1-FB	21.50	22.91	22.13	1.38	1.18	3.50	5.67	0.33
KA 52.1-FB	variable	A+1.42	A+0.63	1.38	1.18	3.50	5.67	0.33

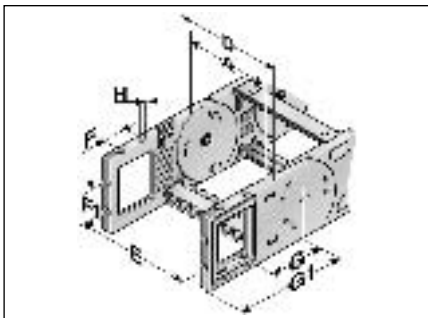

Flexible with threaded bushing

Type	A	D	E	F	F1	G	G1	H
KA 52.1-FG	1.77	3.19	2.40	1.38	1.18	3.50	5.67	M8
KA 52.1-FG	2.44	3.86	3.07	1.38	1.18	3.50	5.67	M8
KA 52.1-FG	2.80	4.21	3.43	1.38	1.18	3.50	5.67	M8
KA 52.1-FG	3.31	4.72	3.94	1.38	1.18	3.50	5.67	M8
KA 52.1-FG	3.78	5.20	4.41	1.38	1.18	3.50	5.67	M8
KA 52.1-FG	4.21	5.63	4.84	1.38	1.18	3.50	5.67	M8
KA 52.1-FG	4.76	6.18	5.39	1.38	1.18	3.50	5.67	M8
KA 52.1-FG	5.67	7.09	6.30	1.38	1.18	3.50	5.67	M8
KA 52.1-FG	5.24	6.65	5.87	1.38	1.18	3.50	5.67	M8
KA 52.1-FG	5.75	7.17	6.38	1.38	1.18	3.50	5.67	M8
KA 52.1-FG	6.22	7.64	6.85	1.38	1.18	3.50	5.67	M8
KA 52.1-FG	6.73	8.15	7.36	1.38	1.18	3.50	5.67	M8
KA 52.1-FG	7.17	8.58	7.80	1.38	1.18	3.50	5.67	M8
KA 52.1-FG	7.72	9.13	8.35	1.38	1.18	3.50	5.67	M8
KA 52.1-FG	8.66	10.08	9.29	1.38	1.18	3.50	5.67	M8
KA 52.1-FG	9.69	11.10	10.31	1.38	1.18	3.50	5.67	M8
KA 52.1-FG	11.65	13.07	12.28	1.38	1.18	3.50	5.67	M8
KA 52.1-FG	13.62	15.04	14.25	1.38	1.18	3.50	5.67	M8
KA 52.1-FG	15.59	17.01	16.22	1.38	1.18	3.50	5.67	M8
KA 52.1-FG	17.56	18.98	18.19	1.38	1.18	3.50	5.67	M8
KA 52.1-FG	19.53	20.94	20.16	1.38	1.18	3.50	5.67	M8
KA 52.1-FG	21.50	22.91	22.13	1.38	1.18	3.50	5.67	M8
KA 52.1-FG	variable	A+1.42	A+0.63	1.38	1.18	3.50	5.67	M8



MP 52.1 - PowerLine

Chain bracket angle

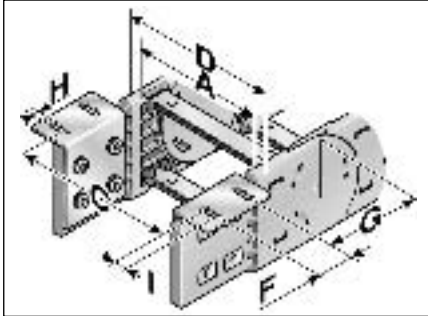

Bottom and top/outside

Type	A inch	C inch	D inch	F inch	G inch	H Ø inch	I inch
KA 52.1	1.77	3.13	3.03	1.26	3.76	0.26	0.55
KA 52.1	2.44	3.80	3.70	1.26	3.76	0.26	0.55
KA 52.1	2.80	4.15	4.06	1.26	3.76	0.26	0.55
KA 52.1	3.31	4.67	4.57	1.26	3.76	0.26	0.55
KA 52.1	3.78	5.14	5.04	1.26	3.76	0.26	0.55
KA 52.1	4.21	5.57	5.47	1.26	3.76	0.26	0.55
KA 52.1	4.76	6.12	6.02	1.26	3.76	0.26	0.55
KA 52.1	5.24	6.59	6.5	1.26	3.76	0.26	0.55
KA 52.1	5.67	7.03	6.93	1.26	3.76	0.26	0.55
KA 52.1	5.75	7.11	7.01	1.26	3.76	0.26	0.55
KA 52.1	6.22	7.58	7.48	1.26	3.76	0.26	0.55
KA 52.1	6.73	8.09	7.99	1.26	3.76	0.26	0.55
KA 52.1	7.17	8.52	8.43	1.26	3.76	0.26	0.55
KA 52.1	7.72	9.07	8.98	1.26	3.76	0.26	0.55
KA 52.1	8.66	10.02	9.92	1.26	3.76	0.26	0.55
KA 52.1	9.69	11.04	10.94	1.26	3.76	0.26	0.55
KA 52.1	11.65	13.01	12.91	1.26	3.76	0.26	0.55
KA 52.1	13.62	14.98	14.88	1.26	3.76	0.26	0.55
KA 52.1	15.59	16.95	16.85	1.26	3.76	0.26	0.55
KA 52.1	17.56	18.92	18.82	1.26	3.76	0.26	0.55
KA 52.1	19.53	20.89	20.79	1.26	3.76	0.26	0.55
KA 52.1	21.50	22.85	22.76	1.26	3.76	0.26	0.55
KA 52.1	variable	A+1.36	A+1.26	1.26	3.76	0.26	0.55

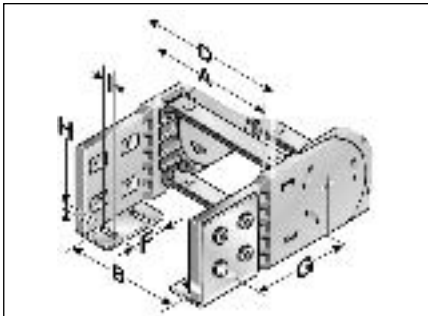

Bottom and top/inside

Type	A inch	B inch	D inch	F inch	G inch	H Ø inch	I inch
KA 52.1	1.77	1.67	3.03	1.26	3.76	0.26	0.55
KA 52.1	2.44	2.34	3.70	1.26	3.76	0.26	0.55
KA 52.1	2.80	2.70	4.06	1.26	3.76	0.26	0.55
KA 52.1	3.31	3.21	4.57	1.26	3.76	0.26	0.55
KA 52.1	3.78	3.68	5.04	1.26	3.76	0.26	0.55
KA 52.1	4.21	4.11	5.47	1.26	3.76	0.26	0.55
KA 52.1	4.76	4.67	6.02	1.26	3.76	0.26	0.55
KA 52.1	5.24	5.14	6.5	1.26	3.76	0.26	0.55
KA 52.1	5.67	5.57	6.93	1.26	3.76	0.26	0.55
KA 52.1	5.75	5.65	7.01	1.26	3.76	0.26	0.55
KA 52.1	6.22	6.12	7.48	1.26	3.76	0.26	0.55
KA 52.1	6.73	6.63	7.99	1.26	3.76	0.26	0.55
KA 52.1	7.17	7.07	8.43	1.26	3.76	0.26	0.55
KA 52.1	7.72	7.62	8.98	1.26	3.76	0.26	0.55
KA 52.1	8.66	8.56	9.92	1.26	3.76	0.26	0.55
KA 52.1	9.69	9.59	10.94	1.26	3.76	0.26	0.55
KA 52.1	11.65	11.56	12.91	1.26	3.76	0.26	0.55
KA 52.1	13.62	13.52	14.88	1.26	3.76	0.26	0.55
KA 52.1	15.59	15.49	16.85	1.26	3.76	0.26	0.55
KA 52.1	17.56	17.46	18.82	1.26	3.76	0.26	0.55
KA 52.1	19.53	19.43	20.79	1.26	3.76	0.26	0.55
KA 52.1	21.50	21.40	22.76	1.26	3.76	0.26	0.55
KA 52.1	variable	A-0.10	A+1.26	1.26	3.76	0.26	0.55

Chain bracket angle

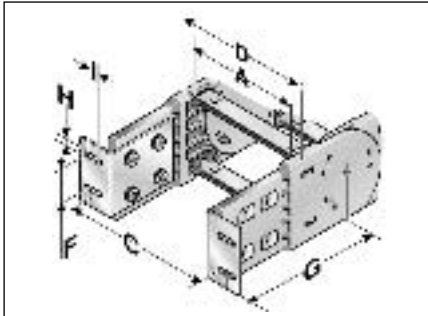

Front/Outside

Type	A inch	C inch	D inch	F inch	G inch	H Ø inch	I inch
KA 52.1	1.77	3.13	3.03	1.26	5.87	0.26	0.55
KA 52.1	2.44	3.80	3.70	1.26	5.87	0.26	0.55
KA 52.1	2.80	4.15	4.06	1.26	5.87	0.26	0.55
KA 52.1	3.31	4.67	4.57	1.26	5.87	0.26	0.55
KA 52.1	3.78	5.14	5.04	1.26	5.87	0.26	0.55
KA 52.1	4.21	5.57	5.47	1.26	5.87	0.26	0.55
KA 52.1	4.76	6.12	6.02	1.26	5.87	0.26	0.55
KA 52.1	5.24	6.59	6.5	1.26	5.87	0.26	0.55
KA 52.1	5.67	7.03	6.93	1.26	5.87	0.26	0.55
KA 52.1	5.75	7.11	7.01	1.26	5.87	0.26	0.55
KA 52.1	6.22	7.58	7.50	1.26	5.87	0.26	0.55
KA 52.1	6.73	8.09	7.99	1.26	5.87	0.26	0.55
KA 52.1	7.17	8.52	8.43	1.26	5.87	0.26	0.55
KA 52.1	7.72	9.07	8.98	1.26	5.87	0.26	0.55
KA 52.1	8.66	10.02	9.92	1.26	5.87	0.26	0.55
KA 52.1	9.69	11.04	10.94	1.26	5.87	0.26	0.55
KA 52.1	11.65	13.01	12.91	1.26	5.87	0.26	0.55
KA 52.1	13.62	14.98	14.88	1.26	5.87	0.26	0.55
KA 52.1	15.59	16.95	16.85	1.26	5.87	0.26	0.55
KA 52.1	17.56	18.92	18.82	1.26	5.87	0.26	0.55
KA 52.1	19.53	20.89	20.79	1.26	5.87	0.26	0.55
KA 52.1	21.50	22.85	22.76	1.26	5.87	0.26	0.55
KA 52.1	variable	A+1.36	A+1.26	1.26	5.87	0.26	0.55

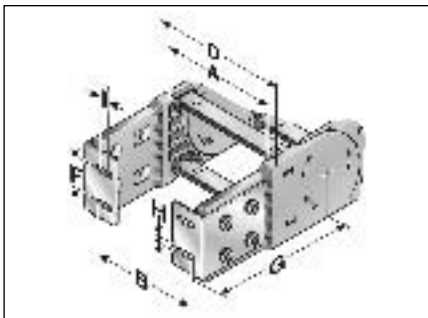

Front/Inside

Type	A inch	B inch	D inch	F inch	G inch	H Ø inch	I inch
KA 52.1	1.77	1.67	3.03	1.26	5.87	0.26	0.55
KA 52.1	2.44	2.34	3.70	1.26	5.87	0.26	0.55
KA 52.1	2.80	2.70	4.06	1.26	5.87	0.26	0.55
KA 52.1	3.31	3.21	4.57	1.26	5.87	0.26	0.55
KA 52.1	3.78	3.68	5.04	1.26	5.87	0.26	0.55
KA 52.1	4.21	4.11	5.47	1.26	5.87	0.26	0.55
KA 52.1	4.76	4.67	6.02	1.26	5.87	0.26	0.55
KA 52.1	5.24	5.14	6.5	1.26	5.87	0.26	0.55
KA 52.1	5.67	5.57	6.93	1.26	5.87	0.26	0.55
KA 52.1	5.75	5.65	7.01	1.26	5.87	0.26	0.55
KA 52.1	6.22	6.12	7.48	1.26	5.87	0.26	0.55
KA 52.1	6.73	6.63	7.99	1.26	5.87	0.26	0.55
KA 52.1	7.17	7.07	8.43	1.26	5.87	0.26	0.55
KA 52.1	7.72	7.62	8.98	1.26	5.87	0.26	0.55
KA 52.1	8.66	8.56	9.92	1.26	5.87	0.26	0.55
KA 52.1	9.69	9.59	10.94	1.26	5.87	0.26	0.55
KA 52.1	11.65	11.56	12.91	1.26	5.87	0.26	0.55
KA 52.1	13.62	13.52	14.88	1.26	5.87	0.26	0.55
KA 52.1	15.59	15.49	16.85	1.26	5.87	0.26	0.55
KA 52.1	17.56	17.46	18.82	1.26	5.87	0.26	0.55
KA 52.1	19.53	19.43	20.79	1.26	5.87	0.26	0.55
KA 52.1	21.50	21.40	22.76	1.26	5.87	0.26	0.55
KA 52.1	variable	A-0.10	A+1.26	1.26	5.87	0.26	0.55



Assembly instruction flexible chain bracket

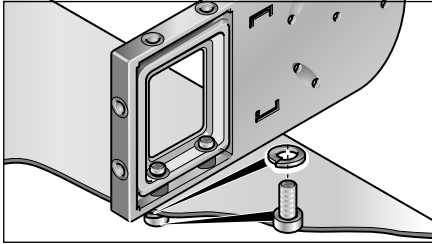

Chain bracket with threaded bushing

Brass bushings guarantee long-lasting fastening without cold flow in the plastic.

Version KA-FB:

Integrated through-hole fastened down using screw and nut.

Version KA-FG:

Built-in threads allow for quick and easy on-site mounting, since a screw, including a retaining washer where necessary, is sufficient.

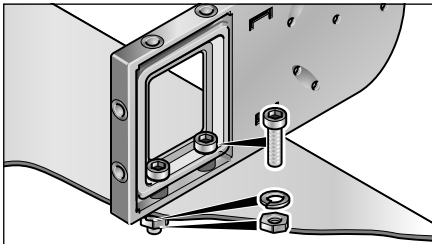

Chain bracket with bushing

Separator

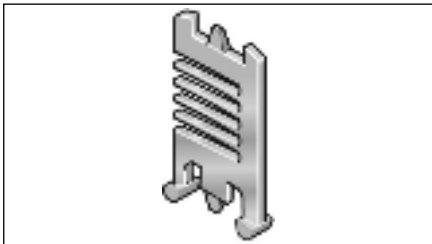

Separator

Type	Order no.	Designation	Pitch inch	Pack qty.
TR 52.1	052100009200	TR 52.1 Separator	0.22	1

We recommend that separators be used if multiple round cables or conduits with differing diameters are to be installed. An offset configuration of the separators is advisable.

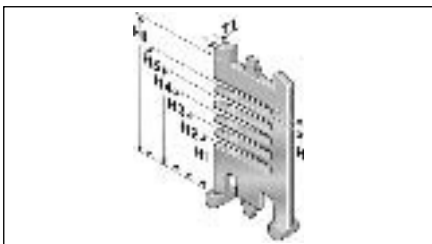

Separator

Type	Tl inch	H inch	H1 inch	H2 inch	H3 inch	H4 inch	H5 inch	Hl inch
TR 52.1	0.14	0.16	0.61	0.87	1.11	1.36	1.61	2.05

H-shaped shelf unit

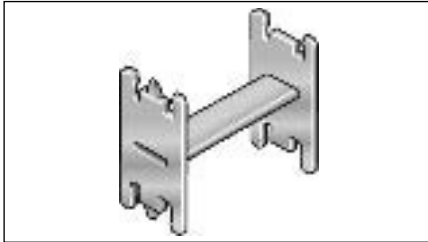

H-shaped shelf unit

Type	Order no.	Designation	Pitch inch	Pack qty.
RE 36/17	100000361714	RE 36/17 H-shaped shelf unit	0.22	1
RE 59/24	100000592414	RE 59/24 H-shaped shelf unit	0.22	1
RE 81/12	100000811214	RE 81/12 H-shaped shelf unit	0.22	1

Insert to obtain additional levels in pre-defined distances.

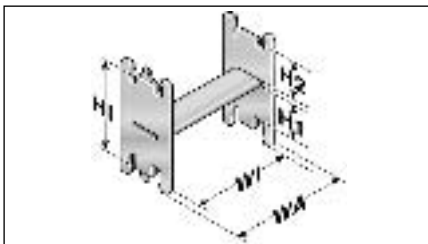

H-shaped shelf unit

Type	WA inch	WI inch	H1 inch	H2 inch	HI inch
RE 36/17	1.67	1.44	1.22	0.69	2.05
RE 59/24	2.56	2.32	0.95	0.95	2.05
RE 81/12	3.44	3.21	1.42	0.49	2.05

Shelving system

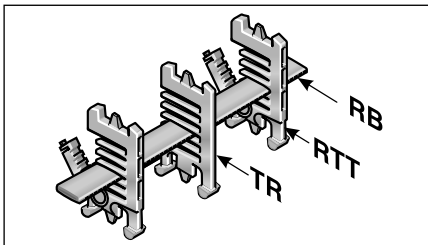

Shelving system

Type	Order no.	Designation	Width inch	Pitch inch	Pack qty.
RB 028-5	100000002800	RB 028-5 Shelf	1.10	0.22	1
RB 056-5	100000005600	RB 056-5 Shelf	2.20	0.22	1
RB 084-5	100000008400	RB 084-5 Shelf	3.31	0.22	1
RB 112-5	100000011200	RB 112-5 Shelf	4.41	0.22	1
RB 140-5	100000014000	RB 140-5 Shelf	5.51	0.22	1
RB 168-5	100000016800	RB 168-5 Shelf	6.61	0.22	1
RB 196-5	100000019600	RB 196-5 Shelf	7.72	0.22	1
RTT 52	100090522000	RTT 52 Shelf support, divisible		0.22	1

In connection with at least two shelf supports (RTT) the shelf becomes a shelving system. The additional levels prevent cables from criss-crossing and therefore destroying each other, while also avoiding excessive friction. Pre-assembly is not necessary as the shelving system and cabling can be assembled quickly and easily on site.

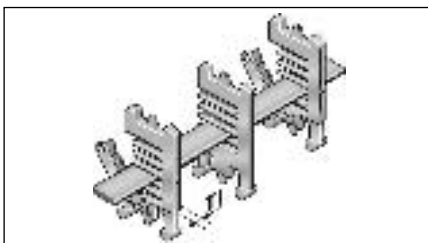

Shelving system

Type	Tl inch
RTT 52	0.28



Crossbar connector

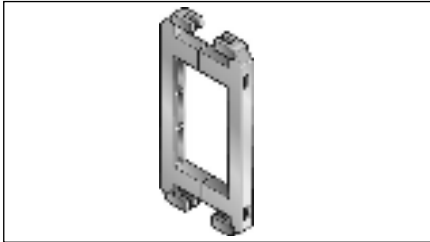

Crossbar connector

Type	Order no.	Designation	Pack qty.
RSV 52	052000009600	RSV 52 Crossbar connector	1
RSV 52 Alu	052000009800	RSV 52 Crossbar connector for aluminum crossbridges	1

For frame bridges wider than 9.69 in (246 mm), we recommend the use of crossbar connectors. These prevent deformation to the frame bridge under large amounts of additional weight of the chain assembly.

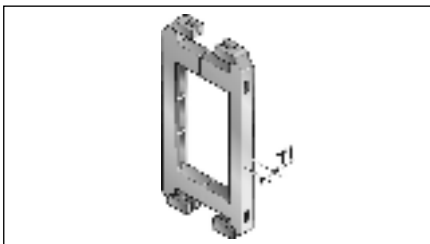

Type	T1 inch
RSV 52	0.30
RSV 52 Alu	0.30

Crossbar strain relief plate RS-ZL

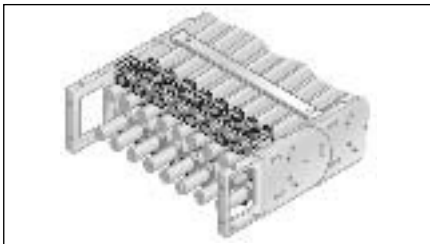

Crossbar strain relief plate RS-ZL

Type	Order no.	For internal width inch	Pack qty.
RS-ZL 045-5	052004500010	1.77	1
RS-ZL 062-5	052006200010	2.44	1
RS-ZL 071-5	052007100010	2.80	1
RS-ZL 084-5	052008400010	3.31	1
RS-ZL 096-5	052009600010	3.78	1
RS-ZL 107-5	052010700010	4.21	1
RS-ZL 121-5	052012100010	4.76	1
RS-ZL 133-5	052013300010	5.24	1
RS-ZL 144/146-5	052014400010	5.67/5.75	1
RS-ZL 158-5	052015800010	6.22	1
RS-ZL 171-5	052017100010	6.73	1
RS-ZL 182-5	052018200010	7.17	1
RS-ZL 196-5	052019600010	7.72	1
RS-ZL 220-5	052022000010	8.66	1
RS-ZL 246-5	052024600010	9.69	1

Fixed integrated frame bridge strain relief plates in the chain brackets. Tailored to all frame bridge widths up to 9.69 in (246 mm). May be assembled on the inside and outside flexure curves at both chain endings.

Strain relief type BAK

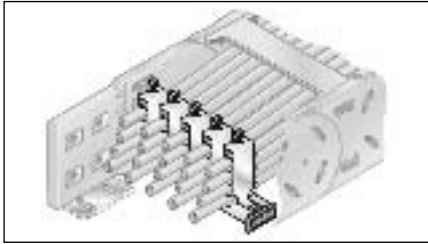

Strain relief with hooped clamp

Type	Order no.	Designation	Ø inch	Number of seats	Pack qty.
C-rail	81661610	C-profile rail			1
BA 12	81661036	BA 12 Hooped clamp	0.35–0.47	1	1
BAK 14	81661002	BAK 14 Hooped clamp	0.24–0.55	1	1
BAK 18	81661004	BAK 18 Hooped clamp	0.55–0.71	1	1
BAK 22	81661006	BAK 22 Hooped clamp	0.71–0.87	1	1
BAK 26	81661008	BAK 26 Hooped clamp	0.87–1.02	1	1
BAK 30	81661010	BAK 30 Hooped clamp	1.02–1.18	1	1
BAK 34	81661000	BAK 34 Hooped clamp	1.18–1.34	1	1
BAK 38	81661044	BAK 38 Hooped clamp	1.34–1.50	1	1
BAK 42	81661032	BAK 42 Hooped clamp	1.50–1.65	1	1
BAK 46	81661050	BAK 46 Hooped clamp	1.65–1.81	1	1
BA 12/2	81661038	BA 12/2 Hooped clamp	0.35–0.47	2	1
BAK 14/2	81661012	BAK 14/2 Hooped clamp	0.39–0.55	2	1
BAK 18/2	81661014	BAK 18/2 Hooped clamp	0.55–0.71	2	1
BAK 22/2	81661016	BAK 22/2 Hooped clamp	0.71–0.87	2	1
BAK 26/2	81661018	BAK 26/2 Hooped clamp	0.87–1.02	2	1
BAK 30/2	81661048	BAK 30/2 Hooped clamp	1.02–1.18	2	1
BAK 34/2	81661044	BAK 34/2 Hooped clamp	1.18–1.34	2	1
BAK 38/2	81661046	BAK 38/2 Hooped clamp	1.34–1.50	2	1
BAK 42/2	81661034	BAK 42/2 Hooped clamp	1.50–1.65	2	1
BAK 12/3	81661020	BAK 12/3 Hooped clamp	0.35–0.47	3	1
BAK 14/3	81661022	BAK 14/3 Hooped clamp	0.47–0.55	3	1
BAK 16/3	81661024	BAK 16/3 Hooped clamp	0.55–0.63	3	1
BAK 18/3	81661026	BAK 18/3 Hooped clamp	0.63–0.71	3	1
BAK 20/3	81661028	BAK 20/3 Hooped clamp	0.71–0.79	3	1
BAK 22/3	81661030	BAK 22/3 Hooped clamp	0.79–0.87	3	1

Fixed integrated strain relief in the chain connections. Available in all widths (also individual widths for aluminum frame ridges). May be assembled on the inside and outside flexure curves at both chain endings. Chain content is secured through hooped clamps that are available in different sizes. Material: Galvanized steel.

When ordering please indicate the type of chain and internal width.



Reverse radius

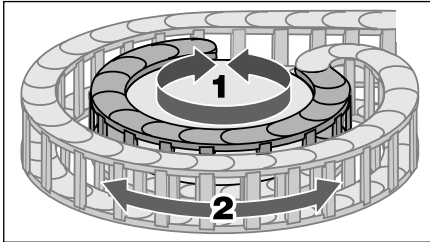

Rotating movement

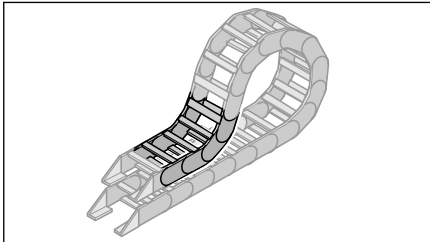

lowered chain bracket

Type	Order no.	Radius inch	Reverse radius inch	Pack qty.
SR 52.1 (RÜ300/R135) left	52100010060	5.31	7.87	1
SR 52.1 (RÜ300/R135) right	52100010062	5.31	7.87	1
SR 52.1 (RÜ300/R170) left	52100015060	6.69	7.87	1
SR 52.1 (RÜ300/R170) right	52100015062	6.69	7.87	1
SR 52.1 (RÜ300/R200) left	52100020060	7.87	7.87	1
SR 52.1 (RÜ300/R200) right	52100020062	7.87	7.87	1
SR 52.1 (RÜ300/R250) left	52100025060	9.84	7.87	1
SR 52.1 (RÜ300/R250) right	52100025062	9.84	7.87	1
SR 52.1 (RÜ300/R300) left	52100030060	11.81	7.87	1
SR 52.1 (RÜ300/R300) right	52100020062	11.81	7.87	1
SR 52.1 (RÜ300/R350) left	52100035060	13.78	7.87	1
SR 52.1 (RÜ300/R350) right	52100035062	13.78	7.87	1

Side links with radius forward (R) and radius backward (Rü) allow for movement in two directions. This is intended for rotating movements and lowered chain brackets.
 Note: This type of chain has different chain links for the left or right side!

Assembly

Disassembly

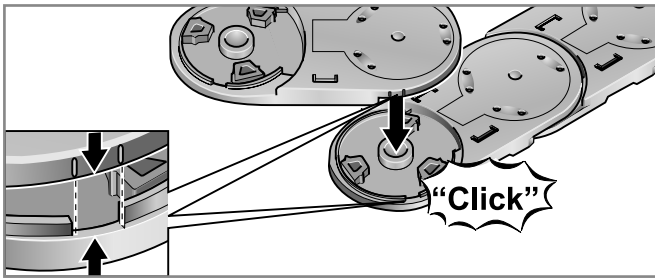

Step 1

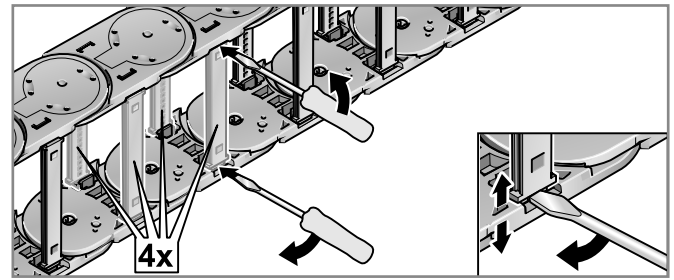

Step 1

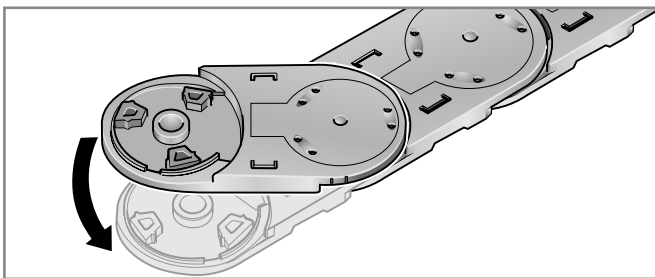

Step 2

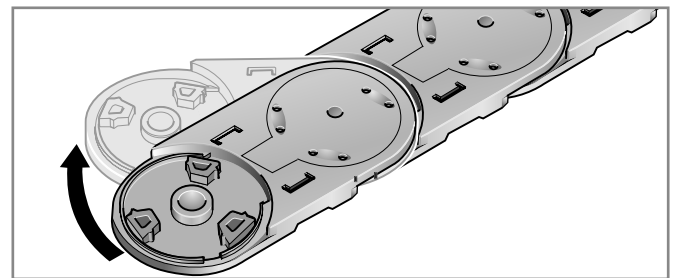

Step 2

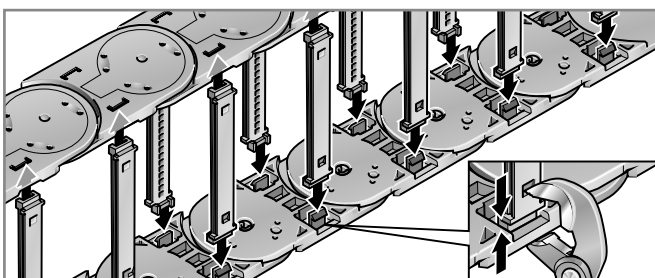

Step 3

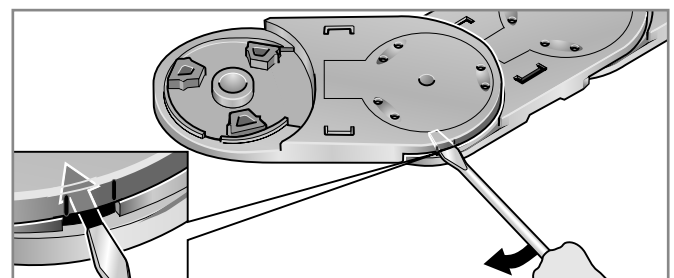

Step 3

Cable drag chain systems

PowerLine

MP 52.2

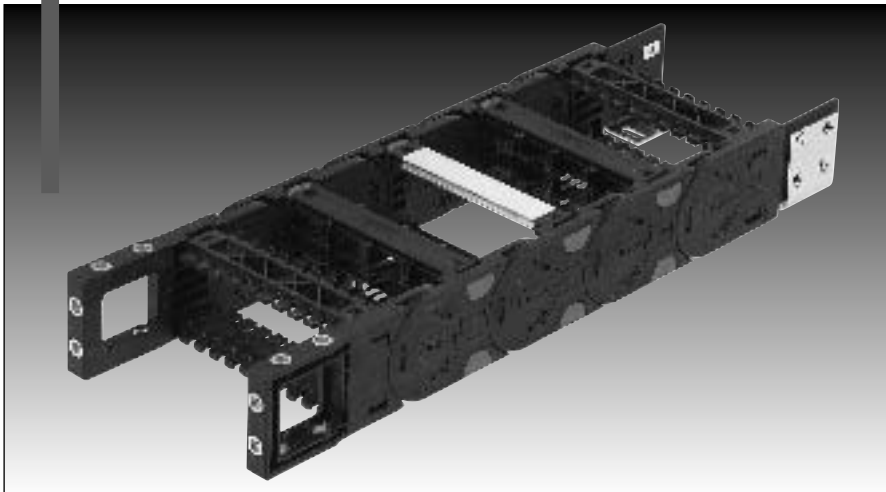



MP 52.2 - PowerLine 2nd generation

Order variants

Style (order code)									
Configuration (order code) *= standard									
Radius (order code) <small>The radii can be combined with any internal width</small>									
in inch									
Internal width (order code)									
in inch									
Outside width in inch									
MP52.2 045	3.03	1.77	045						
MP52.2 062	3.70	2.44	062						
MP52.2 071	4.06	2.80	071						
MP52.2 084	4.57	3.31	084						
MP52.2 096	5.04	3.78	096						
MP52.2 107	5.47	4.21	107						
MP52.2 121	6.02	4.76	121						
MP52.2 133	6.50	5.24	133						
MP52.2 144	6.93	5.67	144						
MP52.2 146	7.01	5.75	146						
MP52.2 158	7.48	6.22	158						
MP52.2 171	7.99	6.73	171						
MP52.2 182	8.43	7.17	182						
MP52.2 196	8.98	7.72	196						
MP52.2 220	9.92	8.66	220						
MP52.2 246	10.94	9.69	246						
MP52.2 296	12.91	11.65	296						0
MP52.2 346	14.88	13.62	346	3.94	100				1
MP52.2 396	16.85	15.59	396	5.91	150				2*
MP52.2 446	18.82	17.56	446	6.89	175				3*
MP52.2 496	20.79	19.53	496	7.87	200				4
MP52.2 546	22.76	21.50	546	9.84	250				5
MP52.2 999	inside + 1.26	>3.15 -23.62	Alu	11.81	300				6
				13.78	350				7
									9

Order-Number:

Configuration:

- 0 PA crossbar every link; w/bias
- 1 PA crossbar every link; w/o bias
- 2* PA crossbar EOL; w/bias
- 3* PA crossbar EOL; w/o bias
- 4 AL crossbar every link; w/bias
- 5 AL crossbar every link; w/o bias
- 6 AL crossbar EOL; w/bias
- 7 AL crossbar EOL; w/o bias
- 9 Custom version

Style:

- 0 Standard (PA/black)
- 5 Polypropylene (PP/blue)
- 7 ESD (PA/light grey)
- 9 Custom version

Sample order:
0522 045 100 0000

Internal width = 1.77 in (45 mm)
Radius = 3.94 in (100 mm)
Configuration = 0
Style = 0

Ideal operating conditions:

- Extreme accelerations
- Extreme speeds
- Very high additional loads
- Both sides must be opened
- Aluminum frame bridge in variable lengths
- Flexible internal separation
- Version with/without bias

Alternative chain type:

- MP 65 G closed series
- MP 66 easier to use
- MP 52.1 greater unsupported length

Features

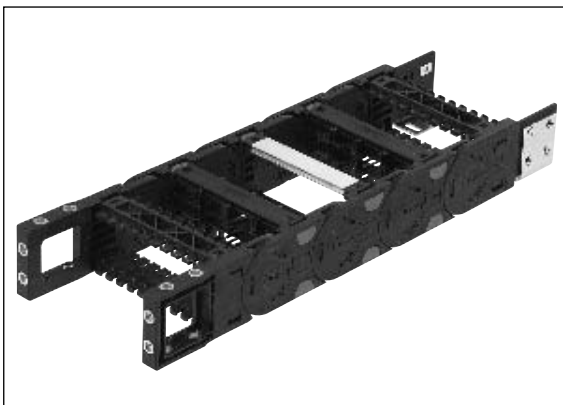

- Chain bracket, can be fastened on three sides
- Crossbar strain relief can be integrated into chain bracket
- Side links with CLICK lock for easy opening
- ESD cable drag chains for use in areas at risk of explosion
- Aluminum frame bridges with integrated lock grid in variable lengths
- Chain bracket with variably positionable metal angle
- Crossbar/cover can be removed from inside and outside flexure curve
- Radii with or without bias (RV/RK)
- Reverse radius combinations
- Foldable shelf system for reliable cable guidance

Technical data

Chain link dimensions (inch) (mm)

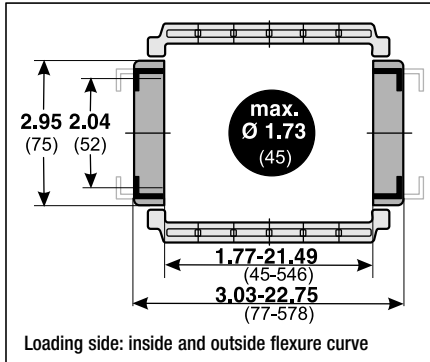

Material characteristics standard (PA/black)

Operating temperature: -22 to 248° F
 Gliding friction factor: 0.30
 Static friction factor: 0.45
 Fire classification: Based on UL94 HB

Other material properties on request

Technical specifications

Travel distance, gliding, L_g : 492.13 ft
 Travel distance, self-supporting, L_s : see diagram
 Travel distance, vertical, hanging, L_{vh} : 328.08 ft
 Travel distance, vertical, upright, L_{vu} : 19.69 ft
 Rotated 90°, self-supporting, L_{90r} : 6.56 ft
 Speed, gliding, V_g : 16.40 ft/s
 Speed, self-supporting, V_s : 65.62 ft/s
 Acceleration, gliding, a_g : 82.02 ft/s²
 Acceleration, self-supporting, a_s : 98.43 ft/s²

Self-supporting length

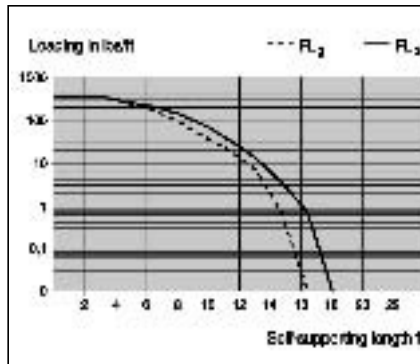
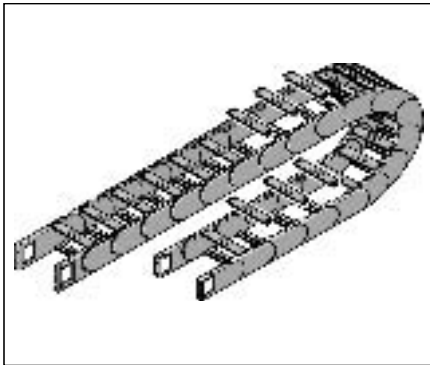

FL_g :
 Ideal installation situation for high stresses at the limit of the max. travel parameters. In this range the chain upper run is still biased, straight or has a max. sag of 0.39 – 1.97 in (10 – 50 mm) depending on the type of chain.

FL_s :
 Satisfactory installation position for many applications working in the lower to middle range of the max. travel parameters. Depending on the chain type, the sag of the chain upper run is >0.39 – 1.97 in (>10 – 50 mm) but certainly less than the max. sag.

If the sag is greater than FL_s , the arrangement is unsuitable and should be avoided. Please choose a more stable Murrplastik cable drag chain.

Determining the chain length

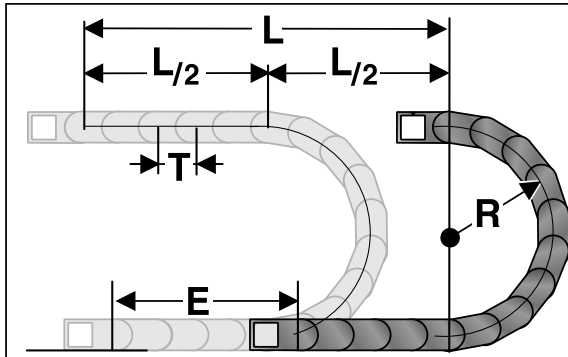

Determining the chain length

$$\text{Length} = \frac{L}{2} + \pi \times R + E$$

$$\approx 1 \text{ ft(m) chain} = 4(11) \text{ links each } 3.58 \text{ in (91 mm)}$$

The fixed point of the cable drag chain should be connected in the middle of the travel distance. This arrangement gives the shortest connection between the fixed point and the moving point and thus the most efficient chain length.

Installation dimensions (in inch)

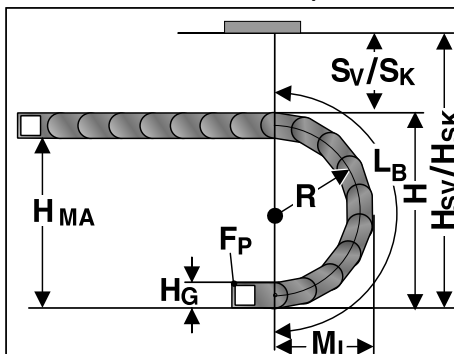

Radius R	3.94	5.91	6.89	7.87	9.84	11.81	13.78
Outside height of chain link (H_o)	2.91	2.91	2.91	2.91	2.91	2.91	2.91
Height of bend (H)	11.97	15.91	17.87	19.84	23.78	27.12	31.65
Height of moving end connection (H_{ma})	9.06	12.99	14.96	16.93	20.87	24.80	28.74
Safety margin with bias (S_v)	1.81	1.81	1.81	1.81	1.81	1.81	1.81
Installation height with bias (H_{sv})	13.78	17.72	17.87	21.65	25.59	29.53	33.46
Safety margin without bias (S_k)	0.63	0.63	0.63	0.63	0.63	0.63	0.63
Installation height without bias (H_{sk})	12.60	16.54	18.50	20.47	24.41	28.35	32.28
Arc projection (M_l)	9.57	11.54	12.52	13.50	15.47	17.44	19.41
Bend length (L_b)	22.36	28.54	31.65	34.72	40.91	47.09	53.27



MP 52.2 - PowerLine 2nd generation

Chain bracket

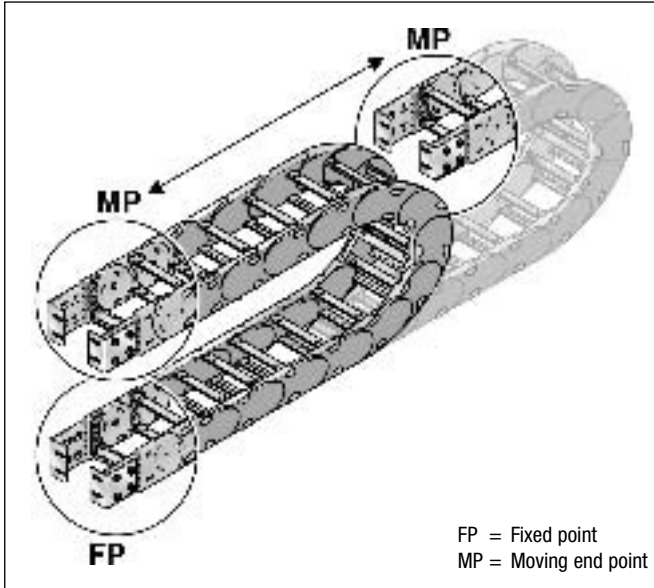

FP = Fixed point
MP = Moving end point

Flexible chain bracket

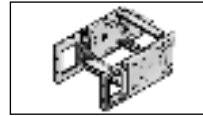

Flexible

Chain bracket angle



Top/Outside

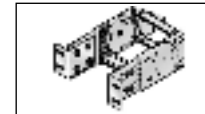

Front/Outside

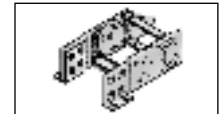

Bottom/Outside

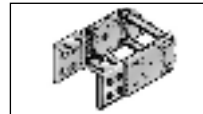

Top/Inside

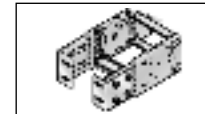

Front/Inside

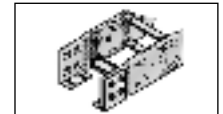

Bottom/Inside

Flexible chain bracket

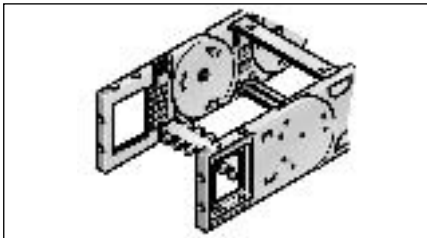

Type	Order no.	Version	Pack qty.
KA 52.1-FB Female end	0521000056	with bushing	1
KA 52.1-FB Male end	0521000057	with bushing	1
KA 52.1-FG Female end	0521000058	with thread	1
KA 52.1-FG Male end	0521000059	with thread	1

This chain bracket offers universal connection options (top, bottom and front) and is attached to the ends of the chain like a side link. This allows the chain to move right up to the bracket. Each chain requires one male and one female bracket. Use M8 screws for connecting. Extrusion-coated metal bushings with either a through-hole (-FB) or a threaded hole (-FG) ensure the permanent, high-strength transmission of even extreme forces onto the cable drag chain.

Chain bracket angle

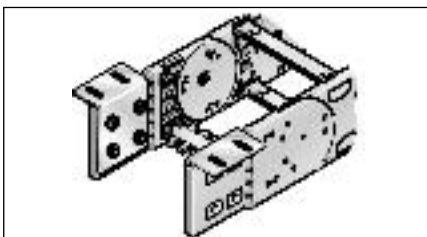

Type	Order no.	Pack qty.
KA 52.1 Female end	0521000050	1
KA 52.1 Male end	0521000051	1

This chain bracket offers universal connection options (top, bottom and front) and is attached to the ends of the chain like a side link. This allows the chain to move right up to the bracket. Each chain requires one male and one female bracket. M6 screws are used to secure the brackets in place.

Flexible chain bracket

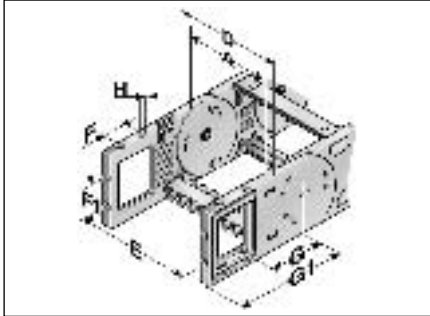

Flexible with through-hole

Type	A inch	D inch	E inch	F inch	F1 inch	G inch	G1 inch	H Ø inch
KA 52.1-FB	1.77	3.19	2.40	1.38	1.18	3.50	5.67	0.33
KA 52.1-FB	2.44	3.86	3.07	1.38	1.18	3.50	5.67	0.33
KA 52.1-FB	2.80	4.21	3.43	1.38	1.18	3.50	5.67	0.33
KA 52.1-FB	3.31	4.72	3.94	1.38	1.18	3.50	5.67	0.33
KA 52.1-FB	3.78	5.20	4.41	1.38	1.18	3.50	5.67	0.33
KA 52.1-FB	4.21	5.63	4.84	1.38	1.18	3.50	5.67	0.33
KA 52.1-FB	4.76	6.18	5.39	1.38	1.18	3.50	5.67	0.33
KA 52.1-FB	5.24	6.65	5.87	1.38	1.18	3.50	5.67	0.33
KA 52.1-FB	5.67	7.09	6.30	1.38	1.18	3.50	5.67	0.33
KA 52.1-FB	5.75	7.17	6.38	1.38	1.18	3.50	5.67	0.33
KA 52.1-FB	6.22	7.64	6.85	1.38	1.18	3.50	5.67	0.33
KA 52.1-FB	6.73	8.15	7.36	1.38	1.18	3.50	5.67	0.33
KA 52.1-FB	7.17	8.58	7.80	1.38	1.18	3.50	5.67	0.33
KA 52.1-FB	7.72	9.13	8.35	1.38	1.18	3.50	5.67	0.33
KA 52.1-FB	8.66	10.08	9.29	1.38	1.18	3.50	5.67	0.33
KA 52.1-FB	9.69	11.10	10.31	1.38	1.18	3.50	5.67	0.33
KA 52.1-FB	11.65	13.07	12.28	1.38	1.18	3.50	5.67	0.33
KA 52.1-FB	13.62	15.04	14.25	1.38	1.18	3.50	5.67	0.33
KA 52.1-FB	15.59	17.01	16.22	1.38	1.18	3.50	5.67	0.33
KA 52.1-FB	17.56	18.98	18.19	1.38	1.18	3.50	5.67	0.33
KA 52.1-FB	19.53	20.94	20.16	1.38	1.18	3.50	5.67	0.33
KA 52.1-FB	21.50	22.91	22.13	1.38	1.18	3.50	5.67	8,5
KA 52.1-FB	variable	A+1.42	A+0.63	1.38	1.18	3.50	5.67	0.33

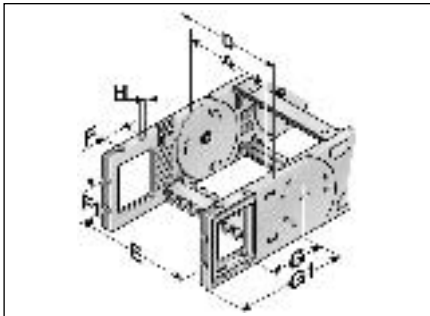

Flexible with threaded bushing

Type	A inch	D inch	E inch	F inch	F1 inch	G inch	G1 inch	H
KA 52.1-FG	1.77	3.19	2.40	1.38	1.18	3.50	5.67	M8
KA 52.1-FG	2.44	3.86	3.07	1.38	1.18	3.50	5.67	M8
KA 52.1-FG	2.80	4.21	3.43	1.38	1.18	3.50	5.67	M8
KA 52.1-FG	3.31	4.72	3.94	1.38	1.18	3.50	5.67	M8
KA 52.1-FG	3.78	5.20	4.41	1.38	1.18	3.50	5.67	M8
KA 52.1-FG	4.21	5.63	4.84	1.38	1.18	3.50	5.67	M8
KA 52.1-FG	4.76	6.18	5.39	1.38	1.18	3.50	5.67	M8
KA 52.1-FG	5.24	6.65	5.87	1.38	1.18	3.50	5.67	M8
KA 52.1-FG	5.67	7.09	6.30	1.38	1.18	3.50	5.67	M8
KA 52.1-FG	5.75	7.17	6.38	1.38	1.18	3.50	5.67	M8
KA 52.1-FG	6.22	7.64	6.85	1.38	1.18	3.50	5.67	M8
KA 52.1-FG	6.73	8.15	7.36	1.38	1.18	3.50	5.67	M8
KA 52.1-FG	7.17	8.58	7.80	1.38	1.18	3.50	5.67	M8
KA 52.1-FG	7.72	9.13	8.35	1.38	1.18	3.50	5.67	M8
KA 52.1-FG	8.66	10.08	9.29	1.38	1.18	3.50	5.67	M8
KA 52.1-FG	9.69	11.10	10.31	1.38	1.18	3.50	5.67	M8
KA 52.1-FG	11.65	13.07	12.28	1.38	1.18	3.50	5.67	M8
KA 52.1-FG	13.62	15.04	14.25	1.38	1.18	3.50	5.67	M8
KA 52.1-FG	15.59	17.01	16.22	1.38	1.18	3.50	5.67	M8
KA 52.1-FG	17.56	18.98	18.19	1.38	1.18	3.50	5.67	M8
KA 52.1-FG	19.53	20.94	20.16	1.38	1.18	3.50	5.67	M8
KA 52.1-FG	21.50	22.91	22.13	1.38	1.18	3.50	5.67	M8
KA 52.1-FG	variable	A+1.42	A+0.63	1.38	1.18	3.50	5.67	M8



MP 52.2 - PowerLine 2nd generation

Chain bracket angle

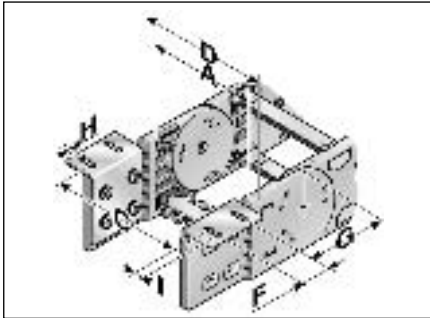

Bottom and top/outside

Type	A inch	C inch	D inch	F inch	G inch	H Ø inch	I inch
KA 52.1	1.77	3.13	3.03	1.26	3.76	0.26	0.55
KA 52.1	2.44	3.80	3.70	1.26	3.76	0.26	0.55
KA 52.1	2.80	4.15	4.06	1.26	3.76	0.26	0.55
KA 52.1	3.31	4.67	4.57	1.26	3.76	0.26	0.55
KA 52.1	3.78	5.14	5.04	1.26	3.76	0.26	0.55
KA 52.1	4.21	5.57	5.47	1.26	3.76	0.26	0.55
KA 52.1	4.76	6.12	6.02	1.26	3.76	0.26	0.55
KA 52.1	5.24	6.59	6.5	1.26	3.76	0.26	0.55
KA 52.1	5.67	7.03	6.93	1.26	3.76	0.26	0.55
KA 52.1	5.75	7.11	7.01	1.26	3.76	0.26	0.55
KA 52.1	6.22	7.58	7.48	1.26	3.76	0.26	0.55
KA 52.1	6.73	8.09	7.99	1.26	3.76	0.26	0.55
KA 52.1	7.17	8.52	8.43	1.26	3.76	0.26	0.55
KA 52.1	7.72	9.07	8.98	1.26	3.76	0.26	0.55
KA 52.1	8.66	10.02	9.92	1.26	3.76	0.26	0.55
KA 52.1	9.69	11.04	10.94	1.26	3.76	0.26	0.55
KA 52.1	11.65	13.01	12.91	1.26	3.76	0.26	0.55
KA 52.1	13.62	14.98	14.88	1.26	3.76	0.26	0.55
KA 52.1	15.59	16.95	16.85	1.26	3.76	0.26	0.55
KA 52.1	17.56	18.92	18.82	1.26	3.76	0.26	0.55
KA 52.1	19.53	20.89	20.79	1.26	3.76	0.26	0.55
KA 52.1	21.50	22.85	22.76	1.26	3.76	0.26	0.55
KA 52.1	variable	A+1.36	A+1.26	1.26	3.76	0.26	0.55

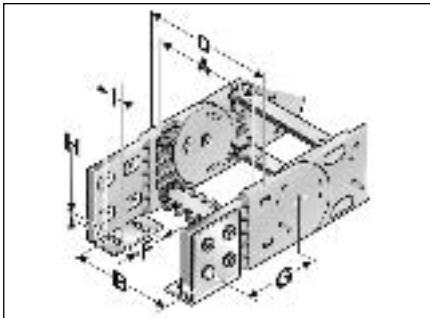

Bottom and top/inside

Type	A inch	B inch	D inch	F inch	G inch	H Ø inch	I inch
KA 52.1	1.77	1.67	3.03	1.26	3.76	0.26	0.55
KA 52.1	2.44	2.34	3.70	1.26	3.76	0.26	0.55
KA 52.1	2.80	2.70	4.06	1.26	3.76	0.26	0.55
KA 52.1	3.31	3.21	4.57	1.26	3.76	0.26	0.55
KA 52.1	3.78	3.68	5.04	1.26	3.76	0.26	0.55
KA 52.1	4.21	4.11	5.47	1.26	3.76	0.26	0.55
KA 52.1	4.76	4.67	6.02	1.26	3.76	0.26	0.55
KA 52.1	5.24	5.14	6.5	1.26	3.76	0.26	0.55
KA 52.1	5.67	5.57	6.93	1.26	3.76	0.26	0.55
KA 52.1	5.75	5.65	7.01	1.26	3.76	0.26	0.55
KA 52.1	6.22	6.12	7.48	1.26	3.76	0.26	0.55
KA 52.1	6.73	6.63	7.99	1.26	3.76	0.26	0.55
KA 52.1	7.17	7.07	8.43	1.26	3.76	0.26	0.55
KA 52.1	7.72	7.62	8.98	1.26	3.76	0.26	0.55
KA 52.1	8.66	8.56	9.92	1.26	3.76	0.26	0.55
KA 52.1	9.69	9.59	10.94	1.26	3.76	0.26	0.55
KA 52.1	11.65	11.56	12.91	1.26	3.76	0.26	0.55
KA 52.1	13.62	13.52	14.88	1.26	3.76	0.26	0.55
KA 52.1	15.59	15.49	16.85	1.26	3.76	0.26	0.55
KA 52.1	17.56	17.46	18.82	1.26	3.76	0.26	0.55
KA 52.1	19.53	19.43	20.79	1.26	3.76	0.26	0.55
KA 52.1	21.50	21.40	22.76	1.26	3.76	0.26	0.55
KA 52.1	variable	A-0.10	A+1.26	1.26	3.76	0.26	0.55

Chain bracket angle

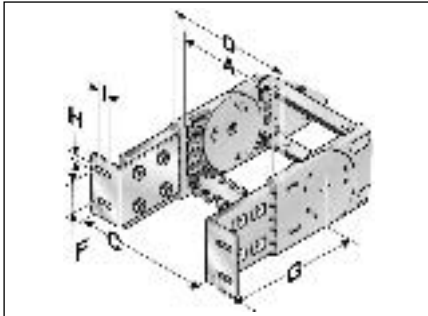

Front/Outside

Type	A inch	C inch	D inch	F inch	G inch	H Ø inch	I inch
KA 52.1	1.77	3.13	3.03	1.26	5.87	0.26	0.55
KA 52.1	2.44	3.80	3.70	1.26	5.87	0.26	0.55
KA 52.1	2.80	4.15	4.06	1.26	5.87	0.26	0.55
KA 52.1	3.31	4.67	4.57	1.26	5.87	0.26	0.55
KA 52.1	3.78	5.14	5.04	1.26	5.87	0.26	0.55
KA 52.1	4.21	5.57	5.47	1.26	5.87	0.26	0.55
KA 52.1	4.76	6.12	6.02	1.26	5.87	0.26	0.55
KA 52.1	5.24	6.59	6.5	1.26	5.87	0.26	0.55
KA 52.1	5.67	7.03	6.93	1.26	5.87	0.26	0.55
KA 52.1	5.75	7.11	7.01	1.26	5.87	0.26	0.55
KA 52.1	6.22	7.58	7.48	1.26	5.87	0.26	0.55
KA 52.1	6.73	8.09	7.99	1.26	5.87	0.26	0.55
KA 52.1	7.17	8.52	8.43	1.26	5.87	0.26	0.55
KA 52.1	7.72	9.07	8.98	1.26	5.87	0.26	0.55
KA 52.1	8.66	10.02	9.92	1.26	5.87	0.26	0.55
KA 52.1	9.69	11.04	10.94	1.26	5.87	0.26	0.55
KA 52.1	11.65	13.01	12.91	1.26	5.87	0.26	0.55
KA 52.1	13.62	14.98	14.88	1.26	5.87	0.26	0.55
KA 52.1	15.59	16.95	16.85	1.26	5.87	0.26	0.55
KA 52.1	17.56	18.92	18.82	1.26	5.87	0.26	0.55
KA 52.1	19.53	20.89	20.79	1.26	5.87	0.26	0.55
KA 52.1	21.50	22.85	22.76	1.26	5.87	0.26	0.55
KA 52.1	variable	A+1.36	A+1.26	1.26	5.87	0.26	0.55

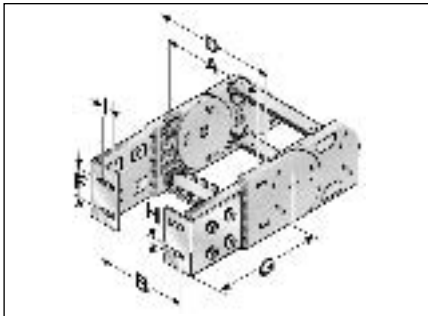

Front/Inside

Type	A inch	B inch	D inch	F inch	G inch	H Ø inch	I inch
KA 52.1	1.77	1.67	3.03	1.26	5.87	0.26	0.55
KA 52.1	2.44	2.34	3.70	1.26	5.87	0.26	0.55
KA 52.1	2.80	2.70	4.06	1.26	5.87	0.26	0.55
KA 52.1	3.31	3.21	4.57	1.26	5.87	0.26	0.55
KA 52.1	3.78	3.68	5.04	1.26	5.87	0.26	0.55
KA 52.1	4.21	4.11	5.47	1.26	5.87	0.26	0.55
KA 52.1	4.76	4.67	6.02	1.26	5.87	0.26	0.55
KA 52.1	5.24	5.14	6.5	1.26	5.87	0.26	0.55
KA 52.1	5.67	5.57	6.93	1.26	5.87	0.26	0.55
KA 52.1	5.75	5.65	7.01	1.26	5.87	0.26	0.55
KA 52.1	6.22	6.12	7.48	1.26	5.87	0.26	0.55
KA 52.1	6.73	6.63	7.99	1.26	5.87	0.26	0.55
KA 52.1	7.17	7.07	8.43	1.26	5.87	0.26	0.55
KA 52.1	7.72	7.62	8.98	1.26	5.87	0.26	0.55
KA 52.1	8.66	8.56	9.92	1.26	5.87	0.26	0.55
KA 52.1	9.69	9.59	10.94	1.26	5.87	0.26	0.55
KA 52.1	11.65	11.56	12.91	1.26	5.87	0.26	0.55
KA 52.1	13.62	13.52	14.88	1.26	5.87	0.26	0.55
KA 52.1	15.59	15.49	16.85	1.26	5.87	0.26	0.55
KA 52.1	17.56	17.46	18.82	1.26	5.87	0.26	0.55
KA 52.1	19.53	19.43	20.79	1.26	5.87	0.26	0.55
KA 52.1	21.50	21.40	22.76	1.26	5.87	0.26	0.55
KA 52.1	variable	A-0.10	A+1.26	1.26	5.87	0.26	0.55



Assembly instruction flexible chain bracket

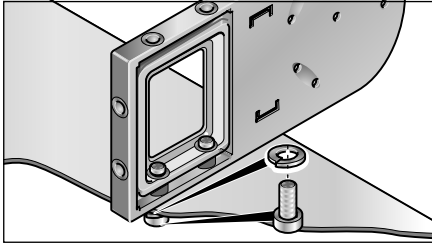

Chain bracket with threaded bushing

Brass bushings guarantee long-lasting fastening without cold flow in the plastic.

Version KA-FB:

Integrated through-hole fastened down using screw and nut.

Version KA-FG:

Built-in threads allow for quick and easy on-site mounting, since a screw, including a retaining washer where necessary, is sufficient.

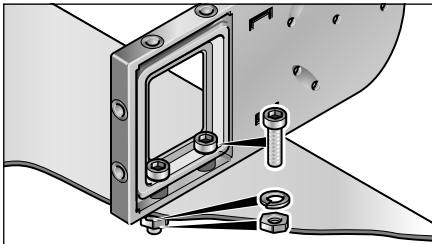

Chain bracket with bushing

Separator

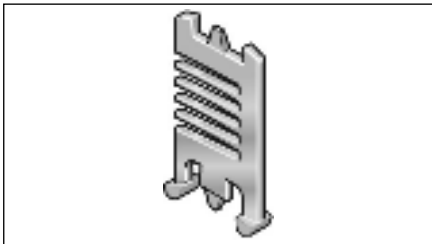

Separator

Type	Order no.	Designation	Pitch inch	Pack qty.
TR 52.1	052100009200	TR 52.1 Separator	0.22	1

We recommend that separators be used if multiple round cables or conduits with differing diameters are to be installed. An offset configuration of the separators is advisable.

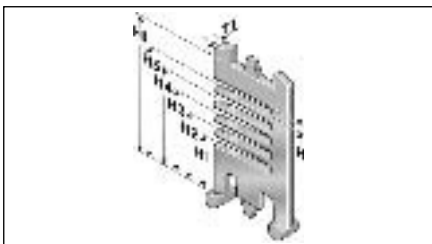

Separator

Type	Tl inch	H inch	H1 inch	H2 inch	H3 inch	H4 inch	H5 inch	Hl inch
TR 52.1	0.14	0.16	0.61	0.87	1.11	1.36	1.61	2.05

H-shaped shelf unit

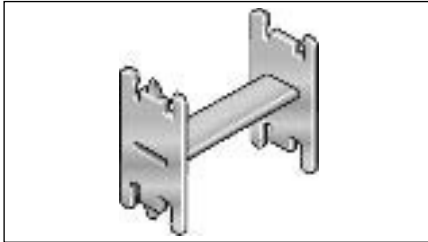

H-shaped shelf unit

Type	Order no.	Designation	Pitch inch	Pack qty.
RE 36/17	100000361714	RE 36/17 H-shaped shelf unit	0.22	1
RE 59/24	100000592414	RE 59/24 H-shaped shelf unit	0.22	1
RE 81/12	100000811214	RE 81/12 H-shaped shelf unit	0.22	1

Insert to obtain additional levels in pre-defined distances.

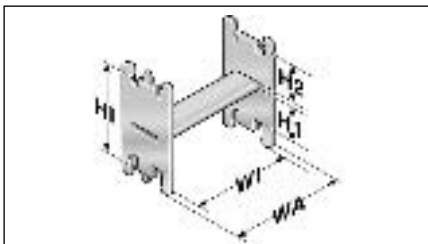

H-shaped shelf unit

Type	WA inch	WI inch	H1 inch	H2 inch	HI inch
RE 36/17	1.67	1.44	1.22	0.69	2.05
RE 59/24	2.56	2.32	0.95	0.95	2.05
RE 81/12	3.44	3.21	1.42	0.49	2.05

Shelving system

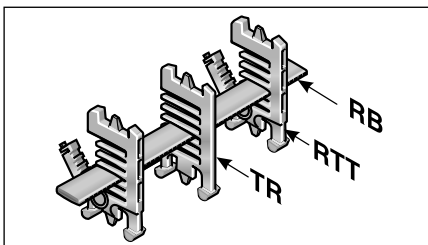

Shelving system

Type	Order no.	Designation	Width inch	Pitch inch	Pack qty.
RB 028-5	100000002800	RB 028-5 Shelf	1.10	0.22	1
RB 056-5	100000005600	RB 056-5 Shelf	2.20	0.22	1
RB 084-5	100000008400	RB 084-5 Shelf	3.31	0.22	1
RB 112-5	100000011200	RB 112-5 Shelf	4.41	0.22	1
RB 140-5	100000014000	RB 140-5 Shelf	5.51	0.22	1
RB 168-5	100000016800	RB 168-5 Shelf	6.61	0.22	1
RB 196-5	100000019600	RB 196-5 Shelf	7.72	0.22	1
RTT 52	100090522000	RTT 52 Shelf support, divisible		0.22	1

In connection with at least two shelf supports (RTT) the shelf becomes a shelving system. The additional levels prevent cables from criss-crossing and therefore destroying each other, while also avoiding excessive friction. Pre-assembly is not necessary as the shelving system and cabling can be assembled quickly and easily on site.

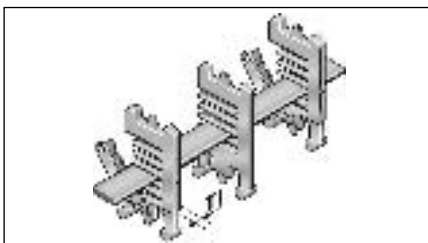

Shelving system

Type	T1 inch
RTT 52	0.28



MP 52.2 - Accessories

Crossbar connector

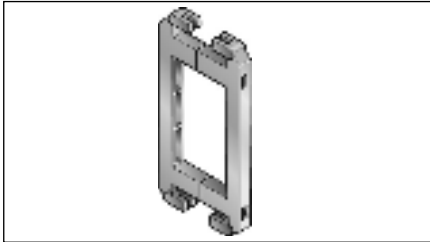

Crossbar connector

Type	Order no.	Designation	Pack qty.
RSV 52	052000009600	RSV 52 Crossbar connector	1
RSV 52 Alu	052000009800	RSV 52 Crossbar connector for aluminum crossbridges	1

For frame bridges wider than 9.69 in (246 mm), we recommend the use of crossbar connectors. These prevent deformation to the frame bridge under large amounts of additional weight of the chain assembly.

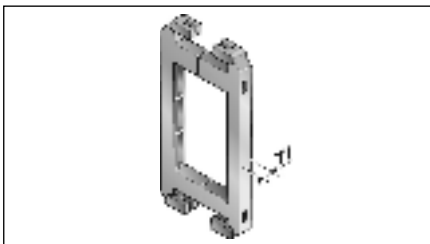

Type	TI inch
RSV 52	0.30
RSV 52 Alu	0.30

Crossbar strain relief plate RS-ZL

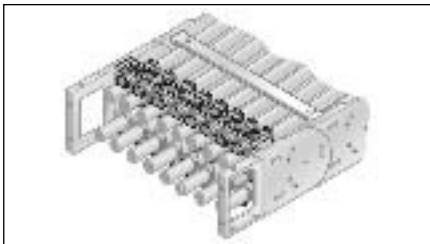

Crossbar strain relief plate RS-ZL

Type	Order no.	For internal width inch	Pack qty.
RS-ZL 045-5	052004500010	1.77	1
RS-ZL 062-5	052006200010	2.44	1
RS-ZL 071-5	052007100010	2.80	1
RS-ZL 084-5	052008400010	3.31	1
RS-ZL 096-5	052009600010	3.78	1
RS-ZL 107-5	052010700010	4.21	1
RS-ZL 121-5	052012100010	4.76	1
RS-ZL 133-5	052013300010	5.24	1
RS-ZL 5.67/5.75-5	052014400010	5.67/5.75	1
RS-ZL 158-5	052015800010	6.22	1
RS-ZL 171-5	052017100010	6.73	1
RS-ZL 182-5	052018200010	7.17	1
RS-ZL 196-5	052019600010	7.72	1
RS-ZL 220-5	052022000010	8.66	1
RS-ZL 246-5	052024600010	9.69	1

Fixed integrated frame bridge strain relief plates in the chain brackets. Tailored to all frame bridge widths up to 9.69 in (246 mm). May be assembled on the inside and outside flexure curves at both chain endings.

Strain relief type BAK

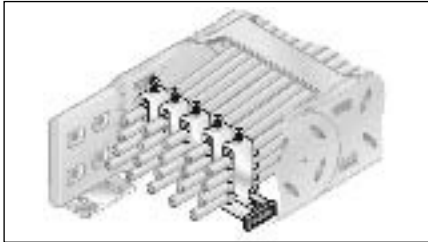

Strain relief with hooped clamp

Type	Order no.	Designation	Ø inch	Number of seats	Pack qty.
C-rail	81661610	C-profile rail			1
BA 12	81661036	BA 12 Hooped clamp	0.35–0.47	1	1
BAK 14	81661002	BAK 14 Hooped clamp	0.24–0.55	1	1
BAK 18	81661004	BAK 18 Hooped clamp	0.55–0.71	1	1
BAK 22	81661006	BAK 22 Hooped clamp	0.71–0.87	1	1
BAK 26	81661008	BAK 26 Hooped clamp	0.87–1.02	1	1
BAK 30	81661010	BAK 30 Hooped clamp	1.02–1.18	1	1
BAK 34	81661000	BAK 34 Hooped clamp	1.18–1.34	1	1
BAK 38	81661044	BAK 38 Hooped clamp	1.34–1.50	1	1
BAK 42	81661032	BAK 42 Hooped clamp	1.50–1.65	1	1
BAK 46	81661050	BAK 46 Hooped clamp	1.65–1.81	1	1
BA 12/2	81661038	BA 12/2 Hooped clamp	0.35–0.47	2	1
BAK 14/2	81661012	BAK 14/2 Hooped clamp	0.39–0.55	2	1
BAK 18/2	81661014	BAK 18/2 Hooped clamp	0.55–0.71	2	1
BAK 22/2	81661016	BAK 22/2 Hooped clamp	0.71–0.87	2	1
BAK 26/2	81661018	BAK 26/2 Hooped clamp	0.87–1.02	2	1
BAK 30/2	81661048	BAK 30/2 Hooped clamp	1.02–1.18	2	1
BAK 34/2	81661044	BAK 34/2 Hooped clamp	1.18–1.34	2	1
BAK 38/2	81661046	BAK 38/2 Hooped clamp	1.34–1.50	2	1
BAK 42/2	81661034	BAK 42/2 Hooped clamp	1.50–1.65	2	1
BAK 12/3	81661020	BAK 12/3 Hooped clamp	0.35–0.47	3	1
BAK 14/3	81661022	BAK 14/3 Hooped clamp	0.47–0.55	3	1
BAK 16/3	81661024	BAK 16/3 Hooped clamp	0.55–0.63	3	1
BAK 18/3	81661026	BAK 18/3 Hooped clamp	0.63–0.71	3	1
BAK 20/3	81661028	BAK 20/3 Hooped clamp	0.71–0.79	3	1
BAK 22/3	81661030	BAK 22/3 Hooped clamp	0.79–0.87	3	1

Fixed integrated strain relief in the chain connections. Available in all widths (also individual widths for aluminum frame ridges). May be assembled on the inside and outside flexure curves at both chain endings. Chain content is secured through hooped clamps that are available in different sizes. Material: Galvanized steel.

When ordering please indicate the type of chain and internal width.



Reverse radius

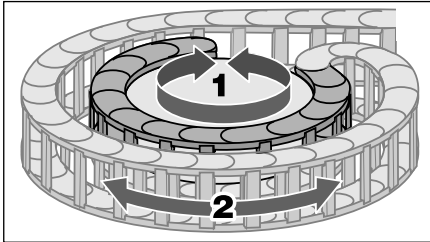

Rotating movement

Type	Order no.	Radius inch	Reverse radius inch	Pack qty.
SR 52.2 (RÜ200/R135) left	52200010060	5.31	7.87	1
SR 52.2 (RÜ200/R135) right	52200010062	5.31	7.87	1
SR 52.2 (RÜ200/R170) left	52200015060	6.69	7.87	1
SR 52.2 (RÜ200/R170) right	52200015062	6.69	7.87	1
SR 52.2 (RÜ300/R200) left	52200020060	7.87	7.87	1
SR 52.2 (RÜ300/R200) right	52200020062	7.87	7.87	1
SR 52.2 (RÜ200/R250) left	52200025060	9.84	7.87	1
SR 52.2 (RÜ200/R250) right	52200025062	9.84	7.87	1
SR 52.2 (RÜ200/R300) left	52200030060	11.81	7.87	1
SR 52.2 (RÜ200/R300) right	52200030062	11.81	7.87	1
SR 52.2 (RÜ200/R350) left	52200035060	13.78	7.87	1
SR 52.2 (RÜ200/R350) right	52200035062	13.78	7.87	1

Side links with radius forward (R) and radius backward (Rü) allow for movement in two directions. This is intended for rotating movements and lowered chain brackets.

Note: This type of chain has different chain links for the left or right side!

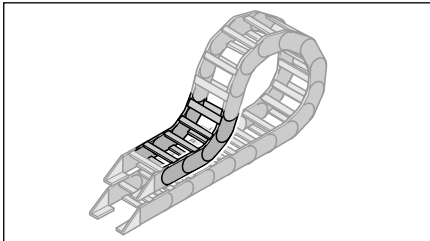

lowered chain bracket

Assembly

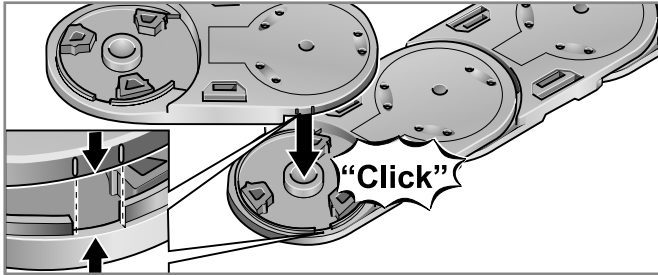

Step 1

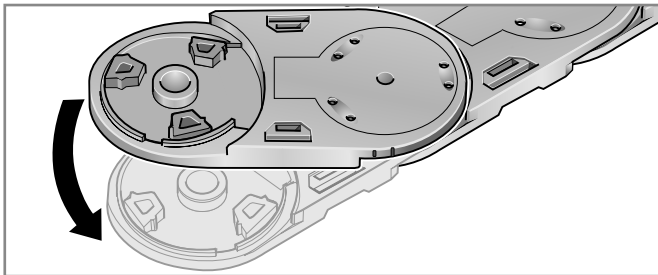

Step 2

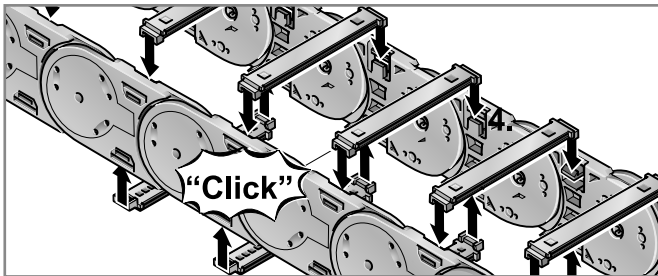

Step 3

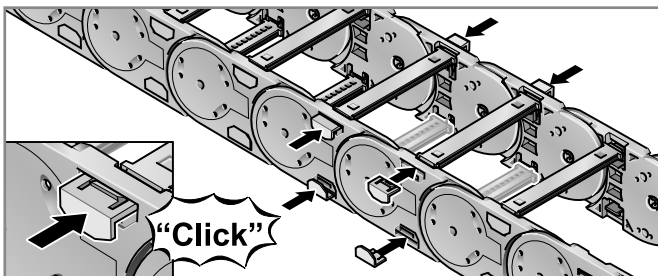

Step 4

Disassembly

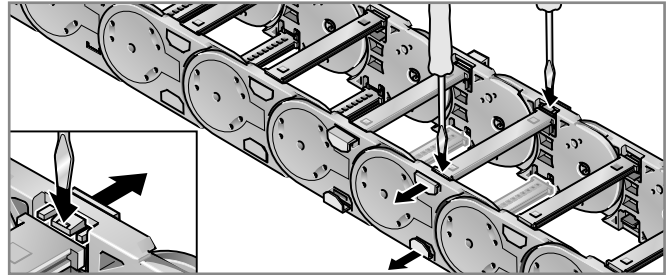

Step 1

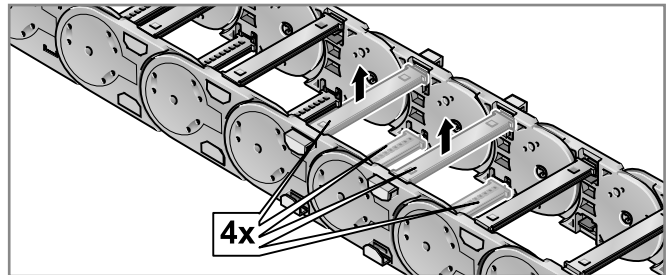

Step 2

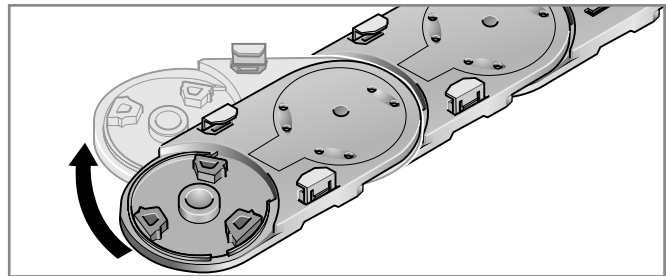

Step 3

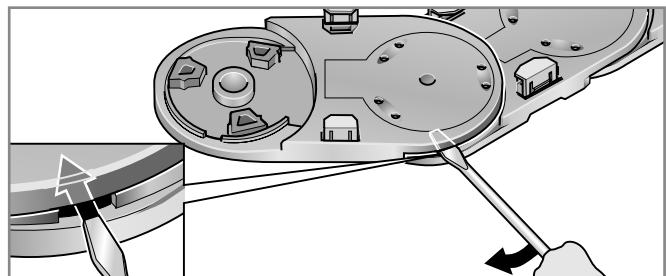

Step 4



Cable Drag Chain Systems

MultiLine

MP 66

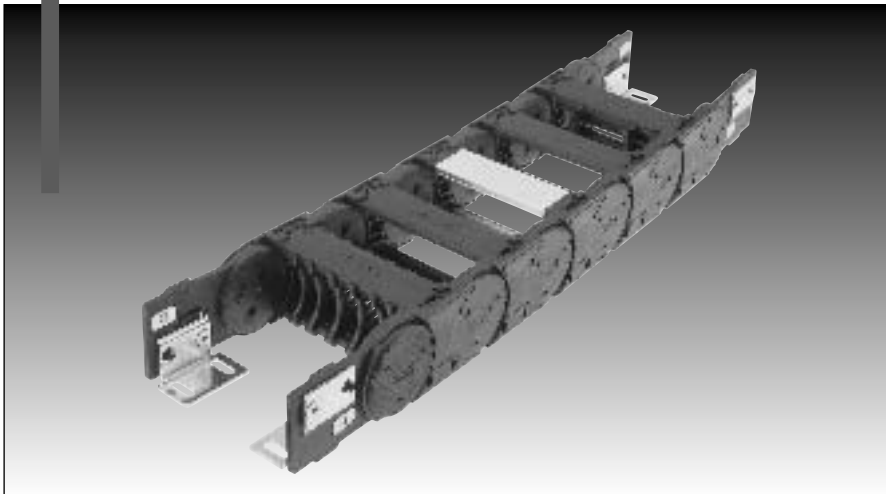



MP 66 - MultiLine

Order variants

Style (order code)									
Configuration (order code) *= standard									
Radius (order code) <small>The radii can be combined with any internal width</small>									
in inch									
Internal width (order code)									
in inch									
Outside width in inch									
MP66 045	3.11	1.77	045						0*
MP66 062	3.78	2.44	062						1*
MP66 084	4.65	3.31	084						2
MP66 105	5.47	4.13	105	5.91	150				3
MP66 144	7.01	5.67	144	7.87	200				4
MP66 182	8.50	7.17	182	9.45	240				5
MP66 xxx	inside + 1.34	>1.77 -23.62	Alu	11.02	280				6
				13.78	350				7
									8
									9
Order-Number:	0660			0					0

Configuration:

- 0* PA crossbar every link; w/bias
- 1* PA crossbar every link; w/o bias
- 2 PA crossbar EOL; w/bias
- 3 PA crossbar EOL; w/o bias
- 4 AL crossbar every link; w/bias
- 5 AL crossbar every link; w/o bias
- 6 AL crossbar EOL; w/bias
- 7 AL crossbar EOL; w/o bias
- 9 Custom version

Style:

- 0 Standard (PA/black)
- 9 Custom version

Sample order:

0660 045 150 0000

Internal width = 1.77 in (45 mm)
 Radius = 5.91 in (150 mm)
 Configuration = 0
 Style = 0

Ideal operating conditions:

- Opening cover in inside/outside bend
- Flexible internal separation
- Aluminum frame bridge in variable lengths
- Gliding arrangement
- Unsupported arrangement
- Quiet operation

Alternative chain type:

- MP 65 G closed series
- MP 62.1/MP 62.2 greater stresses
- MP 62.1/MP 62.2 flange connection (KA-F)

Features

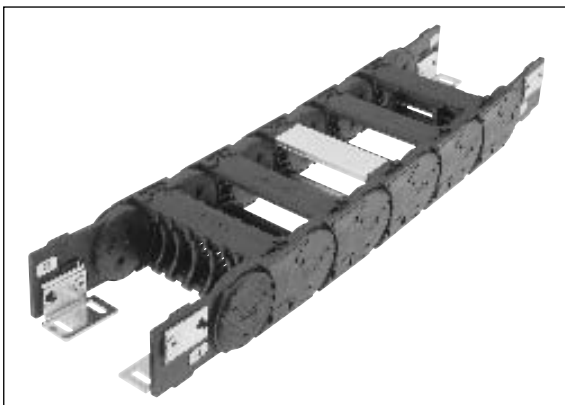

Chain bracket with variably positionable metal angle



Radii with or without bias (RV/RK)



Plug-in shelf system for reliable cable guidance



Crossbar/cover can be removed from inside and outside flexure curve



Aluminum frame bridges with integrated lock grid in variable lengths



Strain relief plate ZL

Technical data

Chain link dimensions (inch) (mm)

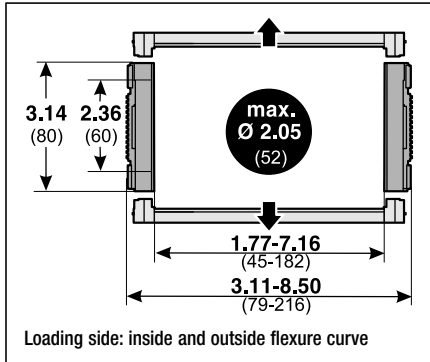

Material characteristics standard (PA/black)

Operating temperature: -22 to 248° F
 Gliding friction factor: 0.30
 Static friction factor: 0.45
 Fire classification: Based on UL94 HB

Other material properties on request

Technical specifications

Travel distance, gliding, L_g : 262.47 ft
 Travel distance, self-supporting, L_s : see diagram
 Travel distance, vertical, hanging, L_{vh} : 164.04 ft
 Travel distance, vertical, upright, L_{vu} : 16.40 ft
 Rotated 90°, self-supporting, L_{90r} : 6.56 ft
 Speed, gliding, V_g : 16.40 ft/s
 Speed, self-supporting, V_s : 49.21 ft/s
 Acceleration, gliding, a_g : 49.21 ft/s²
 Acceleration, self-supporting, a_s : 82.02 ft/s²

Self-supporting length

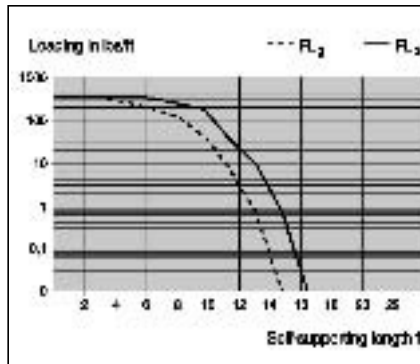
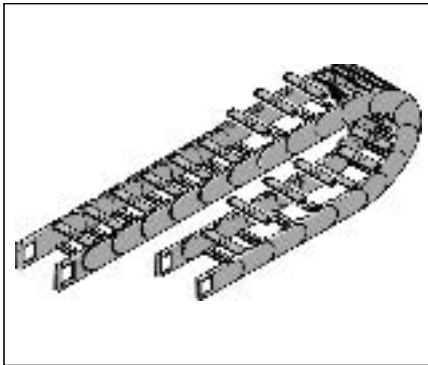

FL₁:
 Ideal installation situation for high stresses at the limit of the max. travel parameters. In this range the chain upper run is still biased, straight or has a max. sag of 0.39 – 1.97 in (10 – 50 mm) depending on the type of chain.

FL₂:
 Satisfactory installation position for many applications working in the lower to middle range of the max. travel parameters. Depending on the chain type, the sag of the chain upper run is >0.39 – 1.97 in (>10 – 50 mm) but certainly less than the max. sag.

If the sag is greater than FL₂, the arrangement is unsuitable and should be avoided. Please choose a more stable Murrplastik cable drag chain.

Determining the chain length

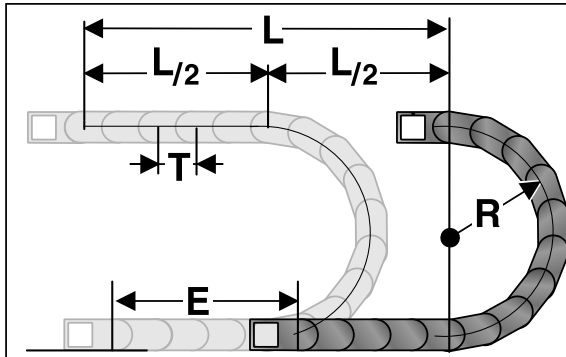

L = Travel distance
 R = Radius
 T = Pitch
 E = Distance between entry point and middle of travel distance

Determining the chain length

$$\text{Length} = \frac{L}{2} + \pi \times R + E$$

$$\approx 1 \text{ ft(m) chain} = 4(11) \text{ links each } 3.60 \text{ in (91,5 mm)}$$

The fixed point of the cable drag chain should be connected in the middle of the travel distance. This arrangement gives the shortest connection between the fixed point and the moving point and thus the most efficient chain length.

Installation dimensions (in inch)

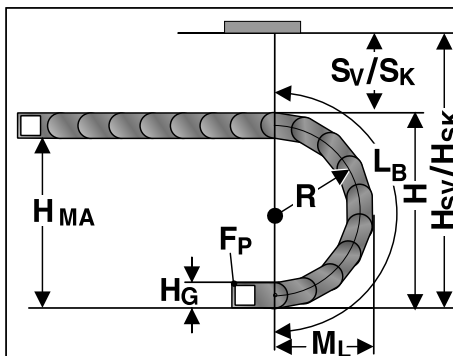

Radius R	5.91	7.87	9.45	11.02	13.78
Outside height of chain link (H_o)	3.15	3.15	3.15	3.15	3.15
Height of bend (H)	14.96	18.90	22.05	25.20	30.71
Height of moving end connection (H_{MA})	11.81	15.75	18.90	22.05	27.56
Safety margin with bias (S_v)	1.97	1.97	1.97	1.97	1.97
Installation height with bias (H_{sv})	16.93	20.87	24.02	27.17	32.68
Safety margin without bias (S_k)	0.59	0.59	0.59	0.59	0.59
Installation height without bias (H_{sk})	15.55	19.49	22.64	25.79	31.30
Arc projection (M_l)	11.10	13.07	14.65	16.22	18.98
Bend length (L_b)	27.09	33.27	38.23	43.15	51.81



Chain bracket

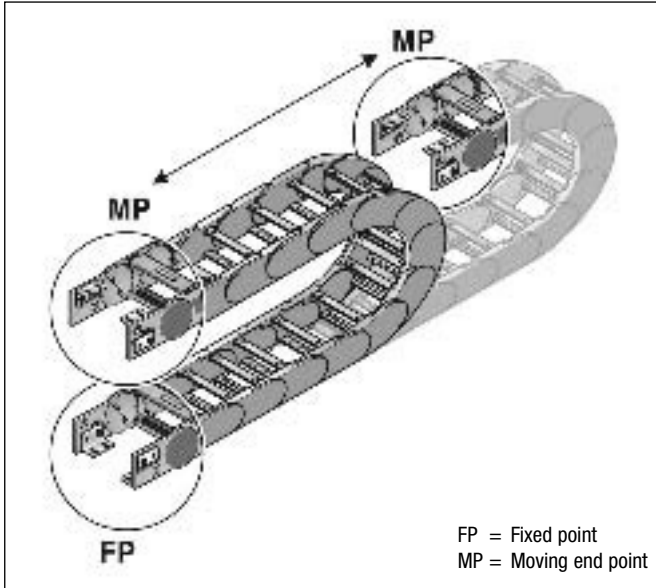

Chain bracket U-part

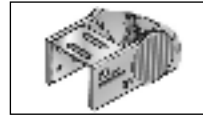

Top



Bottom

Chain bracket angle



Bottom/Outside

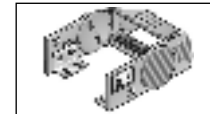

Bottom/Inside

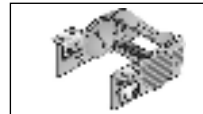

Top/Outside

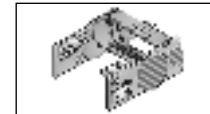

Top/Inside

Chain bracket U-part

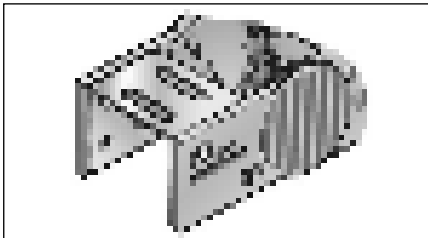

KA 66 U

Type	Order no.	Pack qty.
KA 66 U	0660000054	1

This chain bracket comes standard delivered in a width of 1.77 in (45 mm). Bracket can be mounted up or down.

Chain bracket angle

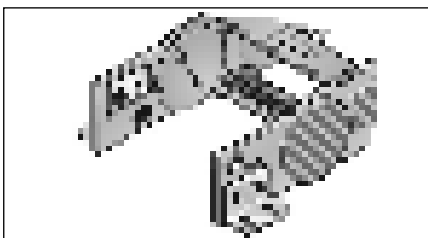

KA 66

Type	Order no.	Material	Pack qty.
KA 66	0660000050	Sheet steel	1
KA 66	0660000060	Stainless steel 1.4301	1

There are several options regarding the chain bracket. The fixed-point bracket (inside/bottom) and the moving end bracket (inside/top) are supplied as standard. However, any other combination can be supplied upon request. The chain bracket is fastened at the end like a side link. This enables the chain to move right up to the bracket. Each chain requires two chain brackets. Fasten the connections with M8 screws.

Chain bracket U-part

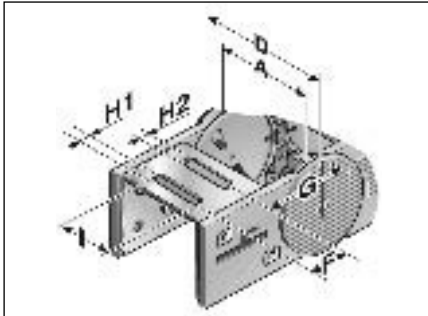

KA 66 U

Type	A inch	D inch	F inch	G inch	H1 inch	H2 inch	I inch
KA 66 U	1.77	3.11	1.10	2.30	0.26	0.33	1.30

Chain bracket angle

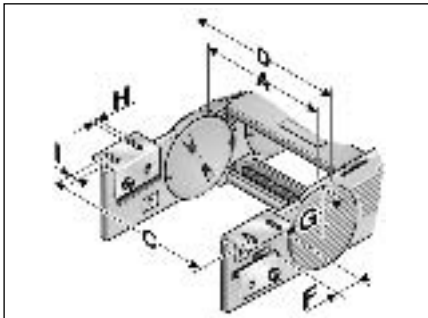

Bottom and top/outside

Type	A inch	C inch	D inch	F inch	G inch	H Ø inch	I inch
KA 66	2.44	4.45	3.78	1.77	1.99	0.35	0.39
KA 66	3.31	5.31	4.63	1.77	1.99	0.35	0.39
KA 66	4.13	6.14	5.47	1.77	1.99	0.35	0.39
KA 66	5.67	7.68	6.99	1.77	1.99	0.35	0.39
KA 66	7.17	9.17	8.50	1.77	1.99	0.35	0.39
KA 66	variable	A+0.08.01	A+1.34	1.77	1.99	0.35	0.39

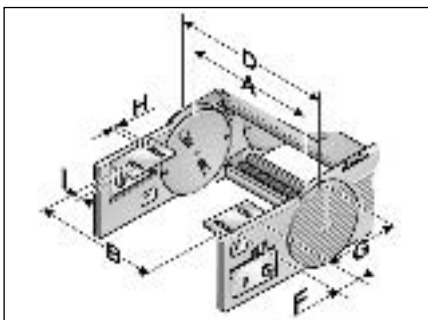

Bottom and top/inside

Type	A	B	D	F	G	H Ø	I
KA 66	2.44	1.77	3.78	1.77	1.99	0.35	0.39
KA 66	3.31	2.64	4.63	1.77	1.99	0.35	0.39
KA 66	4.13	3.46	5.47	1.77	1.99	0.35	0.39
KA 66	5.67	5.00	6.99	1.77	1.99	0.35	0.39
KA 66	7.17	6.5	8.50	1.77	1.99	0.35	0.39
KA 66	variable	A-0.67	A+1.34	1.77	1.99	0.35	0.39



Separator

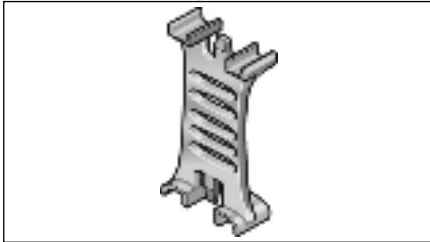

Separator

Type	Order no.	Designation	Lock grid spacing inch	Pack qty.
TV 66	066000009000	Separator	0.06	1

We recommend that separators be used if multiple round cables or conduits with differing diameters are to be installed. An offset configuration of the separators is advisable.

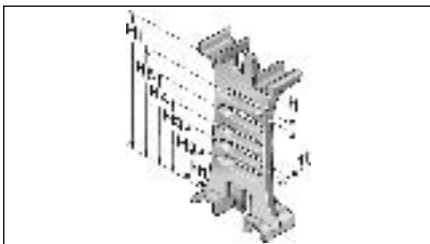

Separator

Type	T1 inch	H inch	H1 inch	H2 inch	H3 inch	H4 inch	H5 inch	H1 inch
TV 66	0.14	0.17	0.71	0.99	1.27	1.55	1.83	2.36

Shelving system

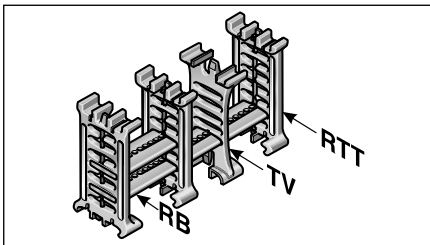

Shelving system

Type	Order no.	Designation	Width inch	Lock grid spacing inch	Pack qty.
RB 031	100000003100	RB 031 Shelf	1.22	0.22	1
RB 048	100000004800	RB 048 Shelf	1.89	0.22	1
RB 070	100000007000	RB 070 Shelf	2.76	0.22	1
RB 092	100000009200	RB 092 Shelf	3.62	0.22	1
RB 100	100000010000	RB 100 Shelf	3.94	0.22	1
RB 128	100000012800	RB 128 Shelf	5.04	0.22	1
RB 167	100000016700	RB 167 Shelf	6.57	0.22	1
RT 66	1000900100	RT 66 Shelf support incl. pin		0.22	1

In connection with at least two shelf supports (RT) the shelf becomes a shelving system. The additional levels prevent cables from criss-crossing and therefore destroying each other, while also avoiding excessive friction. The shelving system may be pre-assembled on request.



Shelving system

Type	T1 inch
RT 66	0.26

Reverse radius

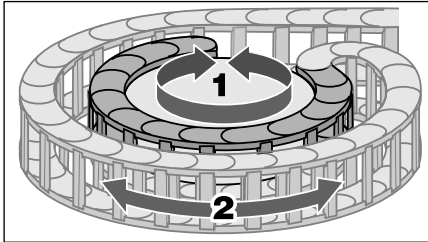

Rotating movement

Type	Order no.	Radius inch	Reverse radius inch	Pack qty.
SR 66 (RÜ240/R150)	66000000060	5.91	9.45	1
SR 66 (RÜ240/R200)	66000000060	7.87	9.45	1
SR 66 (RÜ240/R240)	66000000060	9.45	9.45	1
SR 66 (RÜ240/R280)	66000000060	11.02	9.45	1
SR 66 (RÜ240/R350)	66000000060	13.78	9.45	1

Side links with radius forward (R) and radius backward (Rü) allow for movement in two directions. This is intended for rotating movements and lowered chain brackets. Note: This type of chain has different chain links for the left or right side!

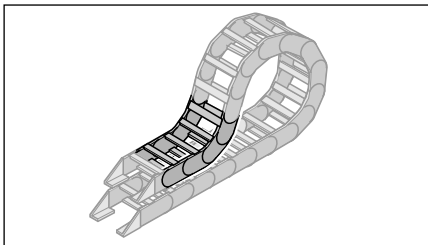

lowered chain bracket



MP 66 - Accessories

Assembly Disassembly

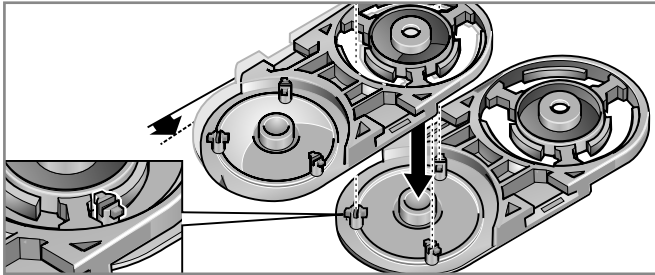

Step 1

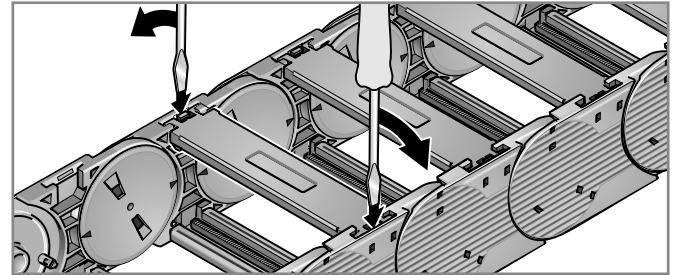

Step 1

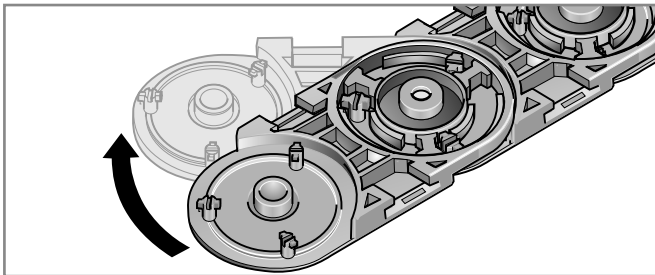

Step 2

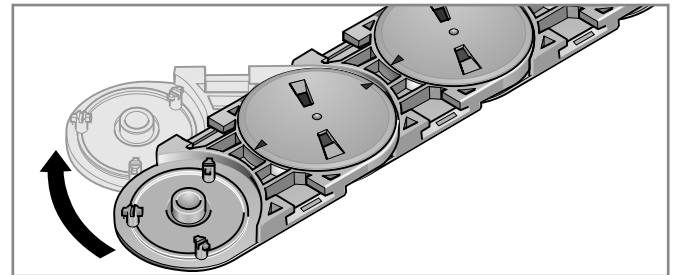

Step 2

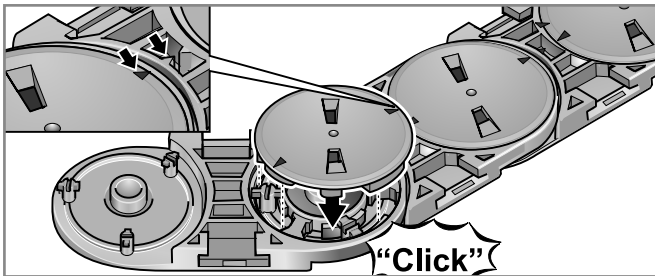

Step 3

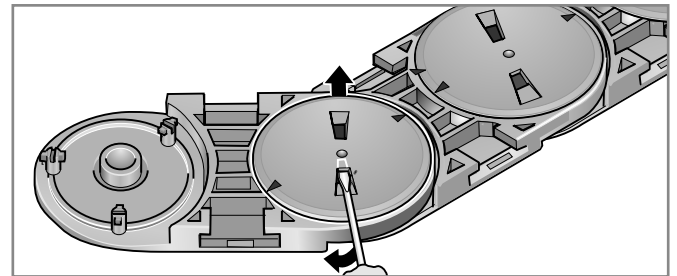

Step 3

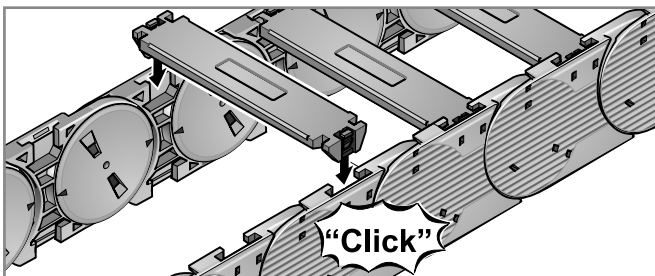

Step 4

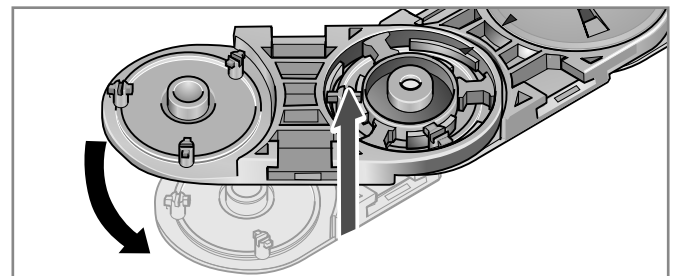

Step 4

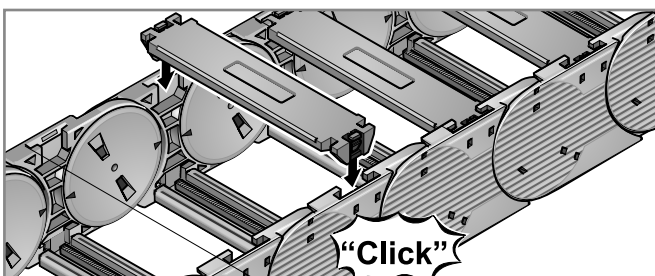

Step 5

Cable drag chain systems

HeavyLine

MP 62.1

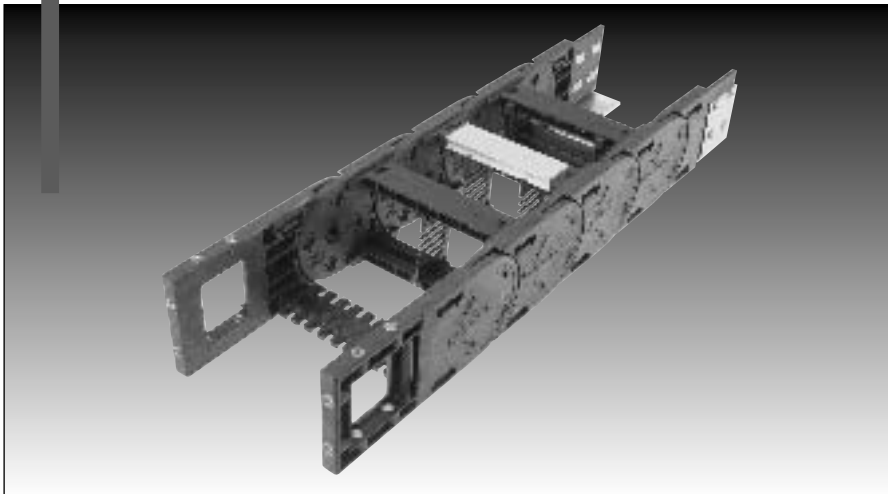



MP 62.1 - HeavyLine

Order variants

Style (order code)							
Configuration (order code) *= standard							
Radius (order code)		The radii can be combined with any internal width					
in inch							
Internal width (order code)							
in inch							
Outside width							
in inch							
MP 62.1 118	5.91	4.65	118				
MP 62.1 143	6.89	5.63	143				
MP 62.1 168	7.87	6.61	168				
MP 62.1 193	8.86	7.60	193				
MP 62.1 218	9.84	8.58	218				
MP 62.1 243	10.38	9.57	243				
MP 62.1 268	11.81	10.55	268				
MP 62.1 293	12.80	11.54	293				
MP 62.1 318	13.78	12.52	318				
MP 62.1 343	14.76	13.50	343				
MP 62.1 368	15.75	14.49	368	5.91	150		
MP 62.1 418	17.72	16.46	418	7.87	200		
MP 62.1 468	19.69	18.43	468	9.84	250		
MP 62.1 518	21.65	20.39	518	11.81	300		
MP 62.1 xxx	inside + 1.26	>4.65 -23.62	Alu	15.75	400		
				19.69	500		
						0	
						1	
						2*	
						3*	
						4	
						5	
						6	
						7	0
						9	9

Order-Number:	<input type="text" value="0620"/>	<input type="text"/>	<input type="text"/>	<input type="text" value="0"/>	<input type="text"/>	<input type="text"/>	<input type="text" value="0"/>
----------------------	-----------------------------------	----------------------	----------------------	--------------------------------	----------------------	----------------------	--------------------------------

Configuration:

- 0 PA crossbar every link; w/bias
- 1 PA crossbar every link; w/o bias
- 2* PA crossbar EOL; w/bias
- 3* PA crossbar EOL; w/o bias
- 4 AL crossbar every link; w/bias
- 5 AL crossbar every link; w/o bias
- 6 AL crossbar EOL; w/bias
- 7 AL crossbar EOL; w/o bias
- 9 Custom version

Style:

- 0 Standard (PA/black)
- 9 Custom version

Sample order:
0620 118 150 0000

Internal width = 4.65 in (118 mm)
Radius = 5.91 in (150 mm)
Configuration = 0
Style = 0

Ideal operating conditions:

- Extreme accelerations
- Extreme speeds
- Extreme self-supporting lengths
- Very high additional loads
- Both sides must be opened
- Aluminum frame bridge in variable lengths
- Flexible internal separation
- Rotated 90° unsupported
- Rotated 90° horizontal
- Version with/without bias

Alternative chain type:

- MP 65 G closed series
- MP 66 easier to use
- MP 62.2 simpler assembly

Features

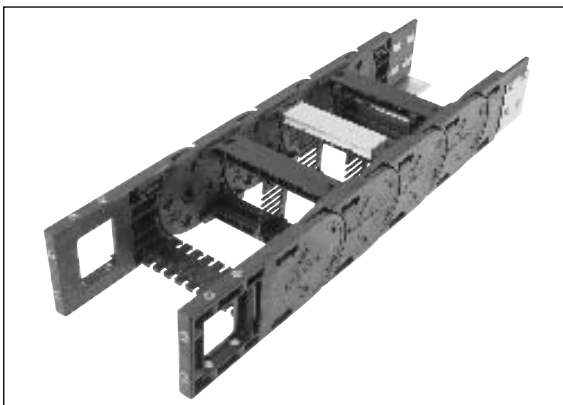

Chain bracket, can be fastened on three sides



Crossbar strain relief can be integrated into chain bracket



Radii with or without bias (RV/RK)



Aluminum frame bridges with integrated lock grid in variable lengths



Chain bracket with variably positionable metal angle



Crossbar/cover can be removed from inside and outside flexure curve



Reverse radius combinations



Foldable shelf system for reliable cable guidance

Technical data

Chain link dimensions (inch) (mm)

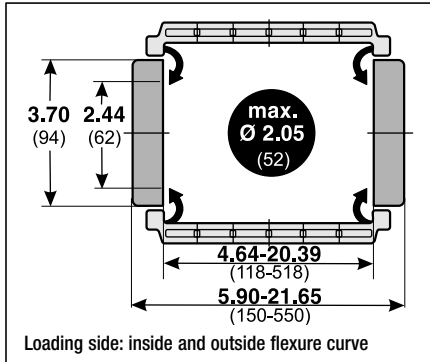

Material characteristics standard (PA/black)

Operating temperature: -22 to 248° F
 Gliding friction factor: 0.30
 Static friction factor: 0.45
 Fire classification: VDE 0304 IIC; UL94 HB

Other material properties on request

Technical specifications

Travel distance, gliding, L_g : 492.13 ft
 Travel distance, self-supporting, L_s : see diagram
 Travel distance, vertical, hanging, L_{vh} : 393.70 ft
 Travel distance, vertical, upright, L_{vu} : 19.69 ft
 Rotated 90°, self-supporting, L_{90r} : 13.12 ft
 Speed, gliding, V_g : 16.40 ft/s
 Speed, self-supporting, V_s : 65.62 ft/s
 Acceleration, gliding, a_g : 82.02 ft/s²
 Acceleration, self-supporting, a_s : 131.23 ft/s²

Self-supporting length

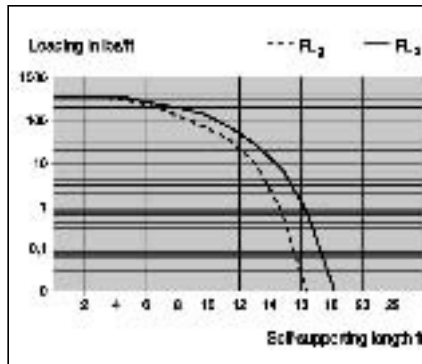
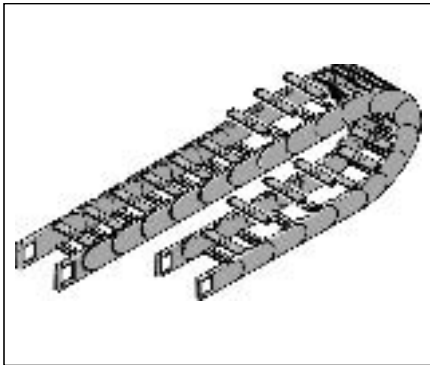

FL_g:
 Ideal installation situation for high stresses at the limit of the max. travel parameters. In this range the chain upper run is still biased, straight or has a max. sag of 0.39 – 1.97 in (10 – 50 mm) depending on the type of chain.

FL_s:
 Satisfactory installation position for many applications working in the lower to middle range of the max. travel parameters. Depending on the chain type, the sag of the chain upper run is >0.39 – 1.97 in (>10 – 50 mm) but certainly less than the max. sag.

If the sag is greater than FL_s, the arrangement is unsuitable and should be avoided. Please choose a more stable Murrplastik cable drag chain.

Determining the chain length

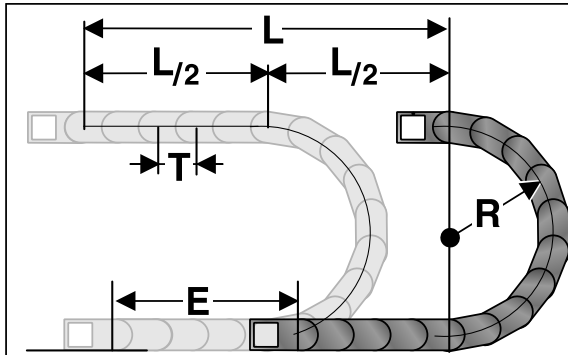

Determining the chain length

$$\text{Length} = \frac{L}{2} + \pi \times R + E$$

$$\approx 1 \text{ ft(m) chain} = 3(10) \text{ links each } 3.94 \text{ in (100 mm)}$$

The fixed point of the cable drag chain should be connected in the middle of the travel distance. This arrangement gives the shortest connection between the fixed point and the moving point and thus the most efficient chain length.

Installation dimensions (in inch)

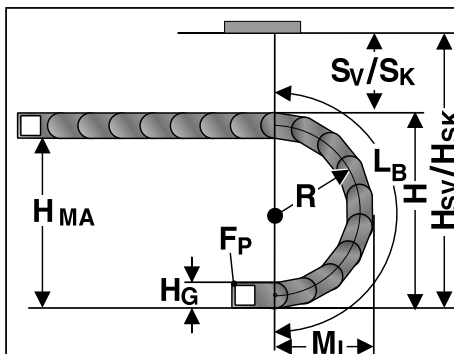

Radius R	5.91	7.87	9.84	11.81	15.75	19.69
Outside height of chain link (H_o)	3.70	3.70	3.70	3.70	3.70	3.70
Height of bend (H)	16.69	20.63	24.57	28.50	36.38	44.25
Height of moving end connection (H_{ma})	12.99	16.93	20.87	24.80	32.68	40.55
Safety margin with bias (S_v)	1.97	1.97	1.97	1.97	1.97	1.97
Installation height with bias (H_{sv})	18.66	22.60	26.54	30.47	38.35	45.16
Safety margin without bias (S_k)	0.79	0.79	0.79	0.79	0.79	0.79
Installation height without bias (H_{sk})	17.48	21.12	25.35	29.29	37.17	45.04
Arc projection (M_l)	12.28	14.25	16.22	18.19	22.13	26.06
Bend length (L_b)	30.16	36.34	42.52	48.70	61.06	73.43



Chain bracket

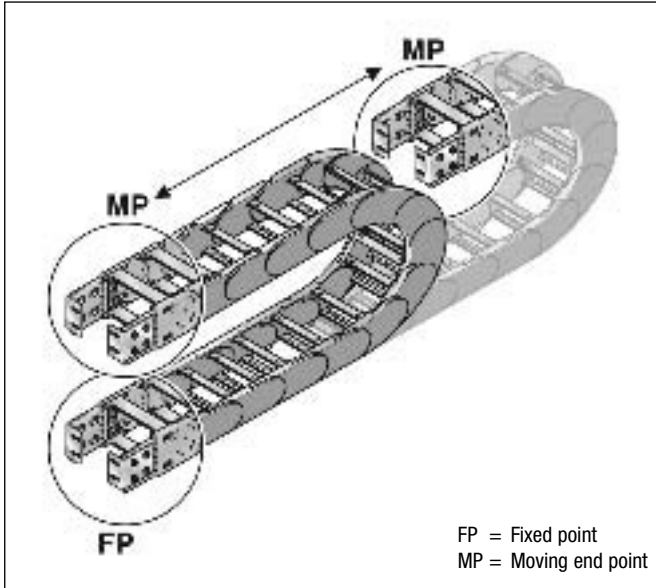

Flexible chain bracket

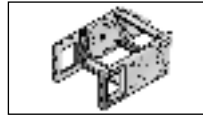

Flexible

Chain bracket angle

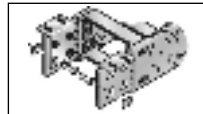

Top/Outside

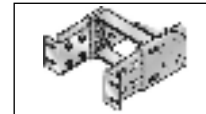

Front/Outside

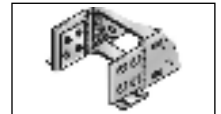

Bottom/Outside

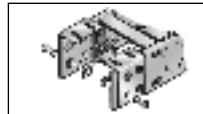

Top/Inside

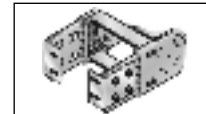

Front/Inside

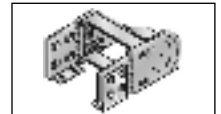

Bottom/Inside

Flexible chain bracket

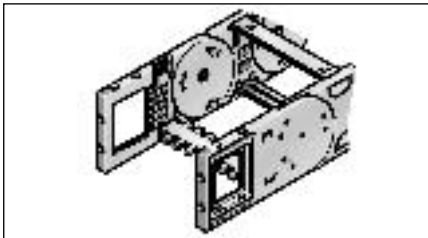

KA 62...

Type	Order no.	Version	Pack qty.
KA 62-FB Female end	0620000056	with bushing	1
KA 62-FB Male end	0620000057	with bushing	1
KA 62-FG Female end	0620000058	with thread	1
KA 62-FG Male end	0620000059	with thread	1

This chain bracket offers universal connection options (top, bottom and front) and is attached to the ends of the chain like a side link. This allows the chain to move right up to the bracket. Each chain requires one male and one female bracket. Use M8 screws for connecting. Extrusion-coated metal bushings with either a through-hole (-FB) or a threaded hole (-FG) ensure the permanent, high-strength transmission of even extreme forces onto the cable drag chain.

Chain bracket angle

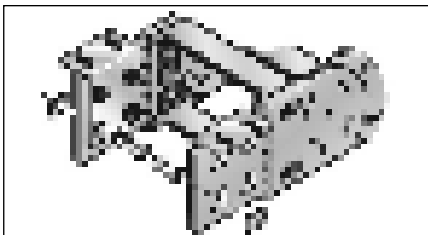

KA 62

Type	Order no.	Pack qty.
KA 62 Female end	0620000050	1
KA 62 Male end	0620000051	1

This chain bracket offers universal connection options (top, bottom and front) and is attached to the ends of the chain like a side link. This allows the chain to move right up to the bracket. Each chain requires one male and one female bracket. Use M8 screws for connecting. Metal inserts (supplied) help to minimize the cold flow properties. This is an enormous advantage, guaranteeing the smooth transfer of high loads to the chain.

Flexible chain bracket

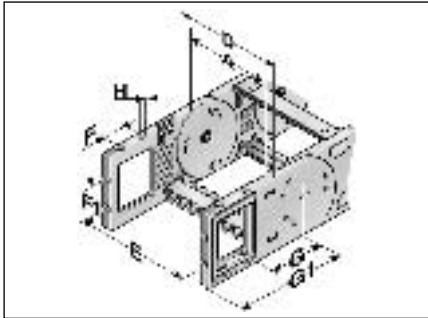

Flexible with through-hole

Type	A inch	D inch	E inch	F inch	F1 inch	G inch	G1 inch	H Ø inch
KA 62-FB	4.65	5.91	5.31	1.38	1.77	4.21	6.75	0.33
KA 62-FB	5.63	6.89	6.30	1.38	1.77	4.21	6.75	0.33
KA 62-FB	6.61	7.87	7.28	1.38	1.77	4.21	6.75	0.33
KA 62-FB	7.60	8.86	8.27	1.38	1.77	4.21	6.75	0.33
KA 62-FB	8.58	9.84	9.25	1.38	1.77	4.21	6.75	0.33
KA 62-FB	9.57	10.83	10.24	1.38	1.77	4.21	6.75	0.33
KA 62-FB	10.55	11.81	11.22	1.38	1.77	4.21	6.75	0.33
KA 62-FB	11.54	9.25	12.20	1.38	1.77	4.21	6.75	0.33
KA 62-FB	12.52	13.78	13.19	1.38	1.77	4.21	6.75	0.33
KA 62-FB	13.50	14.76	14.17	1.38	1.77	4.21	6.75	0.33
KA 62-FB	14.49	13.23	15.16	1.38	1.77	4.21	6.75	0.33
KA 62-FB	16.46	17.72	17.13	1.38	1.77	4.21	6.75	0.33
KA 62-FB	18.43	19.69	19.09	1.38	1.77	4.21	6.75	0.33
KA 62-FB	20.39	21.65	21.06	1.38	1.77	4.21	6.75	0.33
KA 62-FB	variable	A+1.26	A+0.67	1.38	1.77	4.21	6.75	0.33

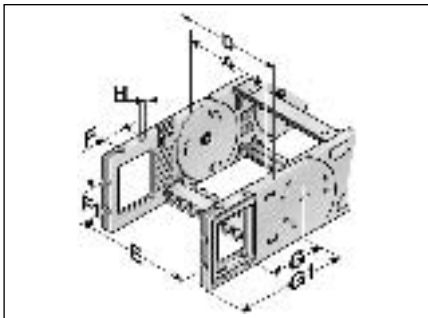

Flexible with threaded bushing

Type	A inch	D inch	E inch	F inch	F1 inch	G inch	G1 inch	H
KA 62-FG	4.65	5.91	5.31	1.38	1.77	4.21	6.75	M8
KA 62-FG	5.63	6.89	6.30	1.38	1.77	4.21	6.75	M8
KA 62-FG	6.61	7.87	7.28	1.38	1.77	4.21	6.75	M8
KA 62-FG	7.60	8.86	8.27	1.38	1.77	4.21	6.75	M8
KA 62-FG	8.58	9.84	9.25	1.38	1.77	4.21	6.75	M8
KA 62-FG	9.57	10.83	10.24	1.38	1.77	4.21	6.75	M8
KA 62-FG	10.55	11.81	11.22	1.38	1.77	4.21	6.75	M8
KA 62-FG	11.54	9.25	12.20	1.38	1.77	4.21	6.75	M8
KA 62-FG	12.52	13.78	13.19	1.38	1.77	4.21	6.75	M8
KA 62-FG	13.50	14.76	14.17	1.38	1.77	4.21	6.75	M8
KA 62-FG	14.49	13.23	15.16	1.38	1.77	4.21	6.75	M8
KA 62-FG	16.46	17.72	17.13	1.38	1.77	4.21	6.75	M8
KA 62-FG	18.43	19.69	19.09	1.38	1.77	4.21	6.75	M8
KA 62-FG	20.39	21.65	21.06	1.38	1.77	4.21	6.75	M8
KA 62-FG	variable	A+1.26	A+0.67	1.38	1.77	4.21	6.75	M8



MP 62.1 - HeavyLine

Chain bracket angle

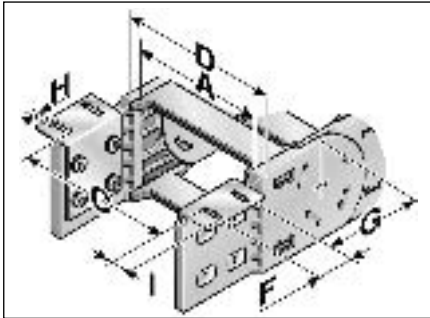

Bottom and top/outside

Type	A inch	C inch	D inch	F inch	G inch	H Ø inch	I inch
KA 62	4.65	6.38	5.91	1.77	4.02	0.35	0.59
KA 62	5.63	7.36	6.89	1.77	4.02	0.35	0.59
KA 62	6.61	8.35	7.87	1.77	4.02	0.35	0.59
KA 62	7.60	9.33	8.86	1.77	4.02	0.35	0.59
KA 62	8.58	10.31	9.84	1.77	4.02	0.35	0.59
KA 62	9.57	11.30	10.83	1.77	4.02	0.35	0.59
KA 62	10.55	12.28	11.81	1.77	4.02	0.35	0.59
KA 62	11.54	13.27	12.80	1.77	4.02	0.35	0.59
KA 62	12.52	14.25	13.78	1.77	4.02	0.35	0.59
KA 62	13.50	15.24	14.76	1.77	4.02	0.35	0.59
KA 62	14.49	16.22	15.75	1.77	4.02	0.35	0.59
KA 62	16.46	18.19	17.72	1.77	4.02	0.35	0.59
KA 62	18.43	20.16	19.69	1.77	4.02	0.35	0.59
KA 62	20.39	22.13	21.65	1.77	4.02	0.35	0.59
KA 62	variable	A+1.73	A+1.26	1.77	4.02	0.35	0.59

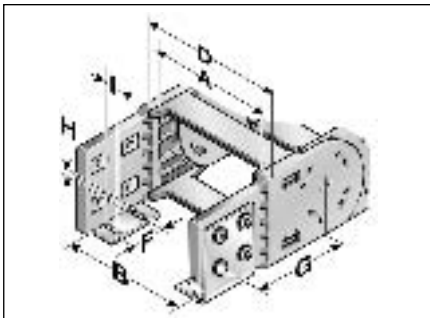

Bottom and top/inside

Type	A inch	B inch	D inch	F inch	G inch	H Ø inch	I inch
KA 62	4.65	4.17	5.91	1.77	4.02	0.35	0.59
KA 62	5.63	5.16	6.89	1.77	4.02	0.35	0.59
KA 62	6.61	6.14	7.87	1.77	4.02	0.35	0.59
KA 62	7.60	7.13	8.86	1.77	4.02	0.35	0.59
KA 62	8.58	8.11	9.84	1.77	4.02	0.35	0.59
KA 62	9.57	9.09	10.83	1.77	4.02	0.35	0.59
KA 62	10.55	10.08	11.81	1.77	4.02	0.35	0.59
KA 62	11.54	11.06	12.80	1.77	4.02	0.35	0.59
KA 62	12.52	12.13	13.78	1.77	4.02	0.35	0.59
KA 62	13.50	13.03	14.76	1.77	4.02	0.35	0.59
KA 62	14.49	14.02	15.75	1.77	4.02	0.35	0.59
KA 62	16.46	15.98	17.72	1.77	4.02	0.35	0.59
KA 62	18.43	17.95	19.69	1.77	4.02	0.35	0.59
KA 62	20.39	19.92	21.65	1.77	4.02	0.35	0.59
KA 62	variable	A-0.47	A+1.26	1.77	4.02	0.35	0.59

Chain bracket angle

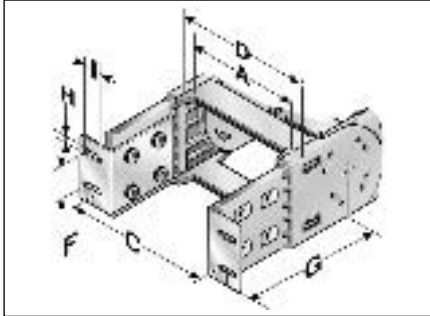

Front/Outside

Type	A inch	C inch	D inch	F inch	G inch	H Ø inch	I inch
KA 62	4.65	6.38	5.91	1.77	6.75	0.35	0.59
KA 62	5.63	7.36	6.89	1.77	6.75	0.35	0.59
KA 62	6.61	8.35	7.87	1.77	6.75	0.35	0.59
KA 62	7.60	9.33	8.86	1.77	6.75	0.35	0.59
KA 62	8.58	10.31	9.84	1.77	6.75	0.35	0.59
KA 62	9.57	11.30	10.83	1.77	6.75	0.35	0.59
KA 62	10.55	12.28	11.81	1.77	6.75	0.35	0.59
KA 62	11.54	13.27	12.80	1.77	6.75	0.35	0.59
KA 62	12.52	14.25	13.78	1.77	6.75	0.35	0.59
KA 62	13.50	15.24	14.76	1.77	6.75	0.35	0.59
KA 62	14.49	16.22	15.75	1.77	6.75	0.35	0.59
KA 62	16.46	18.19	17.72	1.77	6.75	0.35	0.59
KA 62	18.43	20.16	19.69	1.77	6.75	0.35	0.59
KA 62	20.39	22.13	21.65	1.77	6.75	0.35	0.59
KA 62	variable	A+1.73	A+1.26	1.77	6.75	0.35	0.59

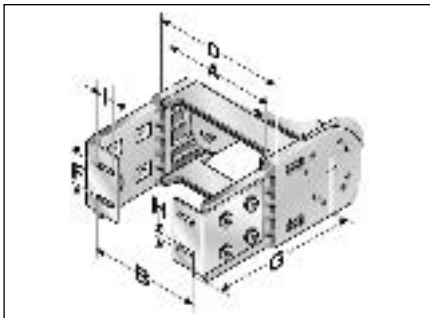

Front/Inside

Type	A inch	B inch	D inch	F inch	G inch	H Ø inch	I inch
KA 62	4.65	4.17	5.91	1.77	6.75	0.35	0.59
KA 62	5.63	5.16	6.89	1.77	6.75	0.35	0.59
KA 62	6.61	6.14	7.87	1.77	6.75	0.35	0.59
KA 62	7.60	7.13	8.86	1.77	6.75	0.35	0.59
KA 62	8.58	8.11	9.84	1.77	6.75	0.35	0.59
KA 62	9.57	9.09	10.83	1.77	6.75	0.35	0.59
KA 62	10.55	10.08	11.81	1.77	6.75	0.35	0.59
KA 62	11.54	11.06	12.80	1.77	6.75	0.35	0.59
KA 62	12.52	12.13	13.78	1.77	6.75	0.35	0.59
KA 62	13.50	13.03	14.76	1.77	6.75	0.35	0.59
KA 62	14.49	14.02	15.75	1.77	6.75	0.35	0.59
KA 62	16.46	15.98	17.72	1.77	6.75	0.35	0.59
KA 62	18.43	17.95	19.69	1.77	6.75	0.35	0.59
KA 62	20.39	19.92	21.65	1.77	6.75	0.35	0.59
KA 62	variable	A-0.47	A+1.26	1.77	6.75	0.35	0.59



Assembly instruction flexible chain bracket

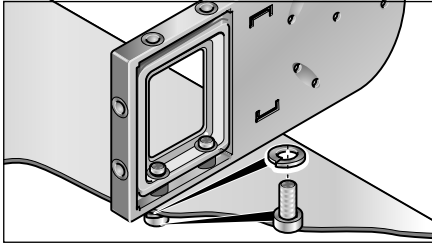

Chain bracket with threaded bushing

Brass bushings guarantee long-lasting fastening without cold flow in the plastic.

Version KA-FB:

Integrated through-hole fastened down using screw and nut.

Version KA-FG:

Built-in threads allow for quick and easy on-site mounting, since a screw, including a retaining washer where necessary, is sufficient.

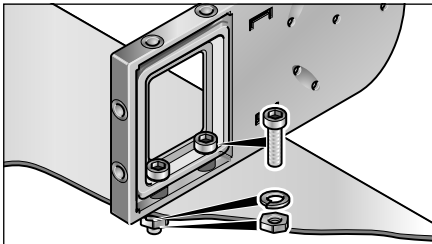

Chain bracket with bushing

Separator

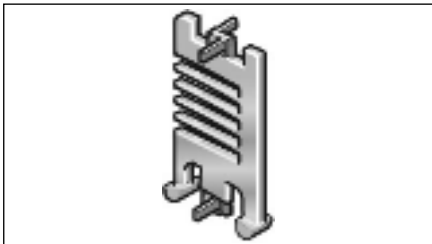

Separator

Type	Order no.	Designation	Lock grid spacing inch	Pack qty.
TR 62	062000009200	Separator	0.20	1

We recommend that separators be used if multiple round cables or conduits with differing diameters are to be installed. An offset configuration of the separators is advisable.

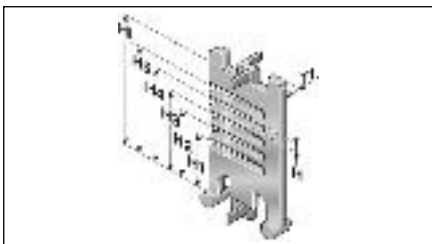

Separator

Type	T1 inch	H inch	H1 inch	H2 inch	H3 inch	H4 inch	H5 inch	H1 inch
TR 62	0.14	0.22	0.58	0.91	1.24	1.56	1.89	2.44

Shelving system

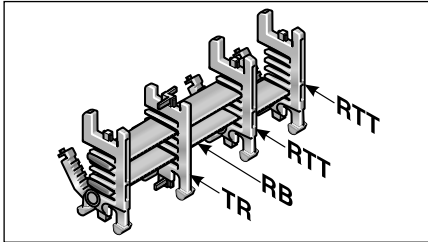

Shelving system

Type	Order no.	Designation	Width inch	Lock grid spacing inch	Pack qty.
RB 056-7	100000005600	RB 056-7 Shelf	2.20	0.20	1
RB 066-7	100000006600	RB 066-7 Shelf	2.60	0.20	1
RB 081-7	100000008100	RB 081-7 Shelf	3.19	0.20	1
RB 106-7	100000010600	RB 106-7 Shelf	4.17	0.20	1
RB 116-7	100000011600	RB 116-7 Shelf	4.57	0.20	1
RB 166-7	100000016600	RB 166-7 Shelf	6.54	0.20	1
RB 216-7	100000021600	RB 216-7 Shelf	8.50	0.20	1
RTT 62	100090622000	RTT 62 Shelf support, divisible		0.20	1

In connection with at least two shelf supports (RTT) the shelf becomes a shelving system. The additional levels prevent cables from criss-crossing and therefore destroying each other, while also avoiding excessive friction. The shelving system may be pre-assembled on request.

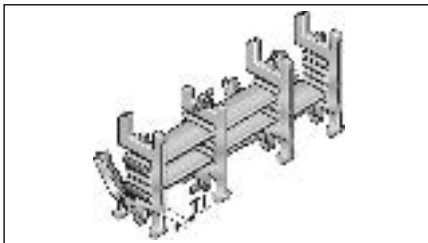

Shelving system

Type	TI inch
RTT 62	0.31

Crossbar connector

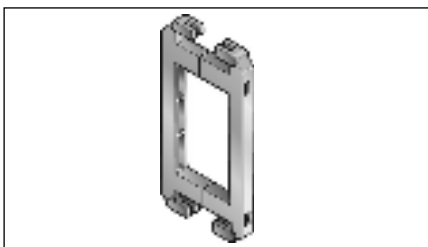

Crossbar connector

Type	Order no.	Designation	Pack qty.
RSV 62	062000009600	RSV 62 Crossbar connector	1
RSV 62 Alu	062000009800	RSV 62 Crossbar connector for aluminum crossbridges	1

For frame bridges wider than 9.69 in (246 mm), we recommend the use of crossbar connectors. These prevent deformation to the frame bridge under large amounts of additional weight of the chain assembly.

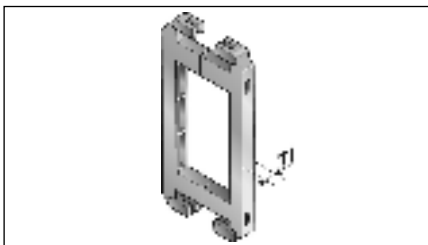

Type	TI inch
RSV 62	0.31
RSV 62 Alu	0.31



Crossbar strain relief plate RS-ZL

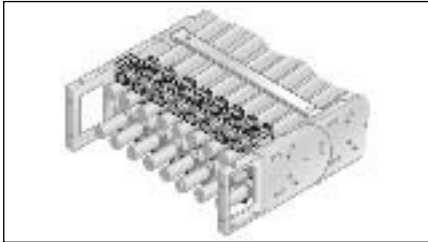

Crossbar strain relief plate RS-ZL

Type	Order no.	For internal width inch	Pack qty.
RS-ZL 118-7	072011800010	4.65	1
RS-ZL 143-7	072014300010	5.63	1
RS-ZL 168-7	072016800010	6.61	1
RS-ZL 193-7	072019300010	7.60	1
RS-ZL 218-7	072021800010	8.58	1
RS-ZL 243-7	072024300010	9.57	1

Fixed integrated frame bridge strain relief plates in the chain brackets. Accommodated to all widths of the frame ridges, up to 9.57 in (243 mm) in size. May be assembled on the inside and outside flexure curves at both chain endings.

Strain relief type BAK

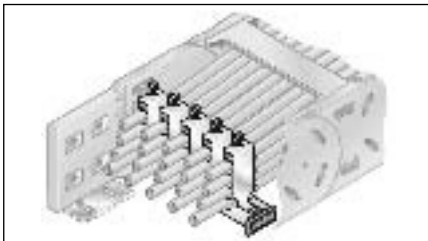

Strain relief with hooped clamp

Type	Order no.	Designation	Ø inch	Number of seats	Pack qty.
C-rail	81661610	C-profile rail			1
BA 12	81661036	BA 12 Hooped clamp	0.35–0.47	1	1
BAK 14	81661002	BAK 14 Hooped clamp	0.24–0.55	1	1
BAK 18	81661004	BAK 18 Hooped clamp	0.55–0.71	1	1
BAK 22	81661006	BAK 22 Hooped clamp	0.71–0.87	1	1
BAK 26	81661008	BAK 26 Hooped clamp	0.87–1.02	1	1
BAK 30	81661010	BAK 30 Hooped clamp	1.02–1.18	1	1
BAK 34	81661000	BAK 34 Hooped clamp	1.18–1.34	1	1
BAK 38	81661044	BAK 38 Hooped clamp	1.34–1.50	1	1
BAK 42	81661032	BAK 42 Hooped clamp	1.50–1.65	1	1
BAK 46	81661050	BAK 46 Hooped clamp	1.65–1.81	1	1
BA 12/2	81661038	BA 12/2 Hooped clamp	0.35–0.47	2	1
BAK 14/2	81661012	BAK 14/2 Hooped clamp	0.39–0.55	2	1
BAK 18/2	81661014	BAK 18/2 Hooped clamp	0.55–0.71	2	1
BAK 22/2	81661016	BAK 22/2 Hooped clamp	0.71–0.87	2	1
BAK 26/2	81661018	BAK 26/2 Hooped clamp	0.87–1.02	2	1
BAK 30/2	81661048	BAK 30/2 Hooped clamp	1.02–1.18	2	1
BAK 34/2	81661044	BAK 34/2 Hooped clamp	1.18–1.34	2	1
BAK 38/2	81661046	BAK 38/2 Hooped clamp	1.34–1.50	2	1
BAK 42/2	81661034	BAK 42/2 Hooped clamp	1.50–1.65	2	1
BAK 12/3	81661020	BAK 12/3 Hooped clamp	0.35–0.47	3	1
BAK 14/3	81661022	BAK 14/3 Hooped clamp	0.47–0.55	3	1
BAK 16/3	81661024	BAK 16/3 Hooped clamp	0.55–0.63	3	1
BAK 18/3	81661026	BAK 18/3 Hooped clamp	0.63–0.71	3	1
BAK 20/3	81661028	BAK 20/3 Hooped clamp	0.71–0.79	3	1
BAK 22/3	81661030	BAK 22/3 Hooped clamp	0.79–0.87	3	1

Fixed integrated strain relief in the chain connections. Available in all widths (also individual widths for aluminum frame ridges). May be assembled on the inside and outside flexure curves at both chain endings. Chain content is secured through hooped clamps that are available in different sizes. Material: Galvanized steel.

When ordering please indicate the type of chain and internal width.

Reverse radius

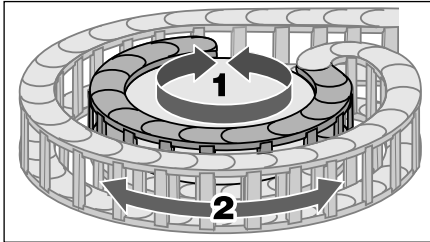

Rotating movement

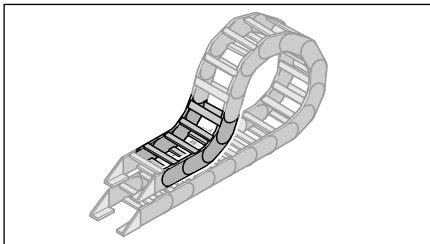

lowered chain bracket

Type	Order no.	Radius inch	Reverse radius inch	Pack qty.
SR 62.1 (RÜ300/R300) left	62100030060	11.81	11.81	1
SR 62.1 (RÜ300/R300) right	62100030062	11.81	11.81	1

Side links with radius forward (R) and radius backward (Rü) allow for movement in two directions. This is intended for rotating movements and lowered chain brackets.
Note: This type of chain has different chain links for the left or right side!

Assembly

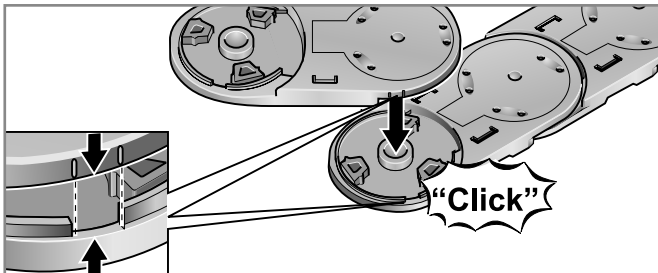

Step 1

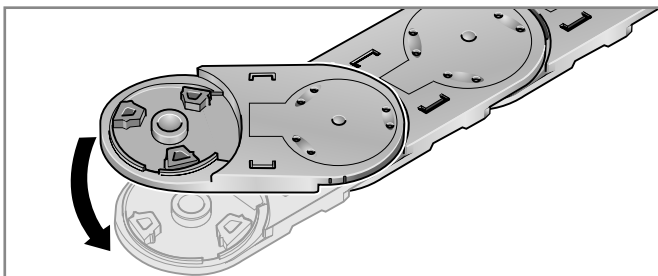

Step 2

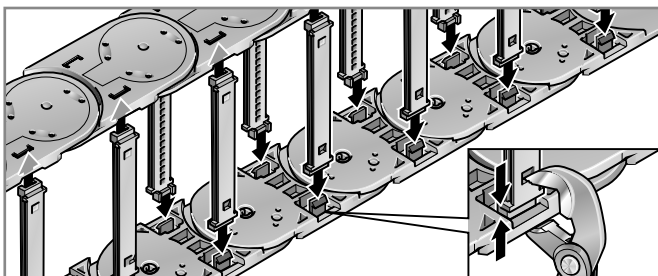

Step 3

Disassembly

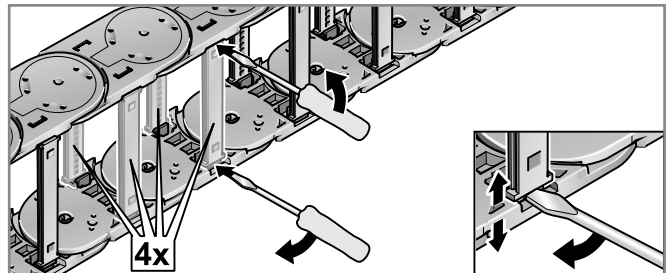

Step 1

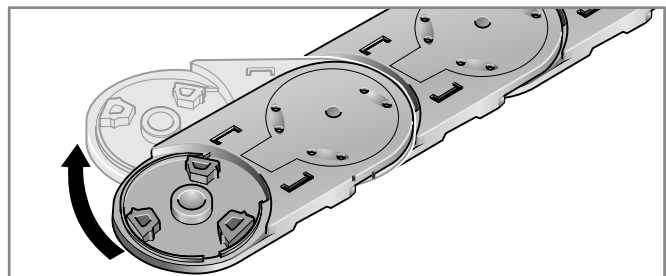

Step 2

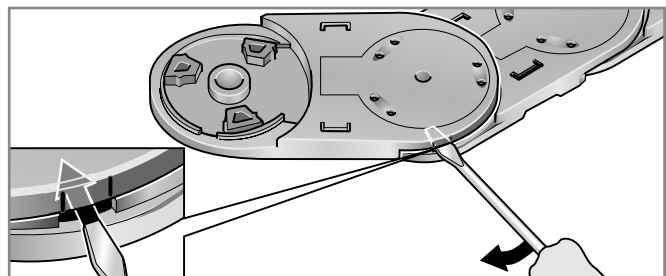

Step 3

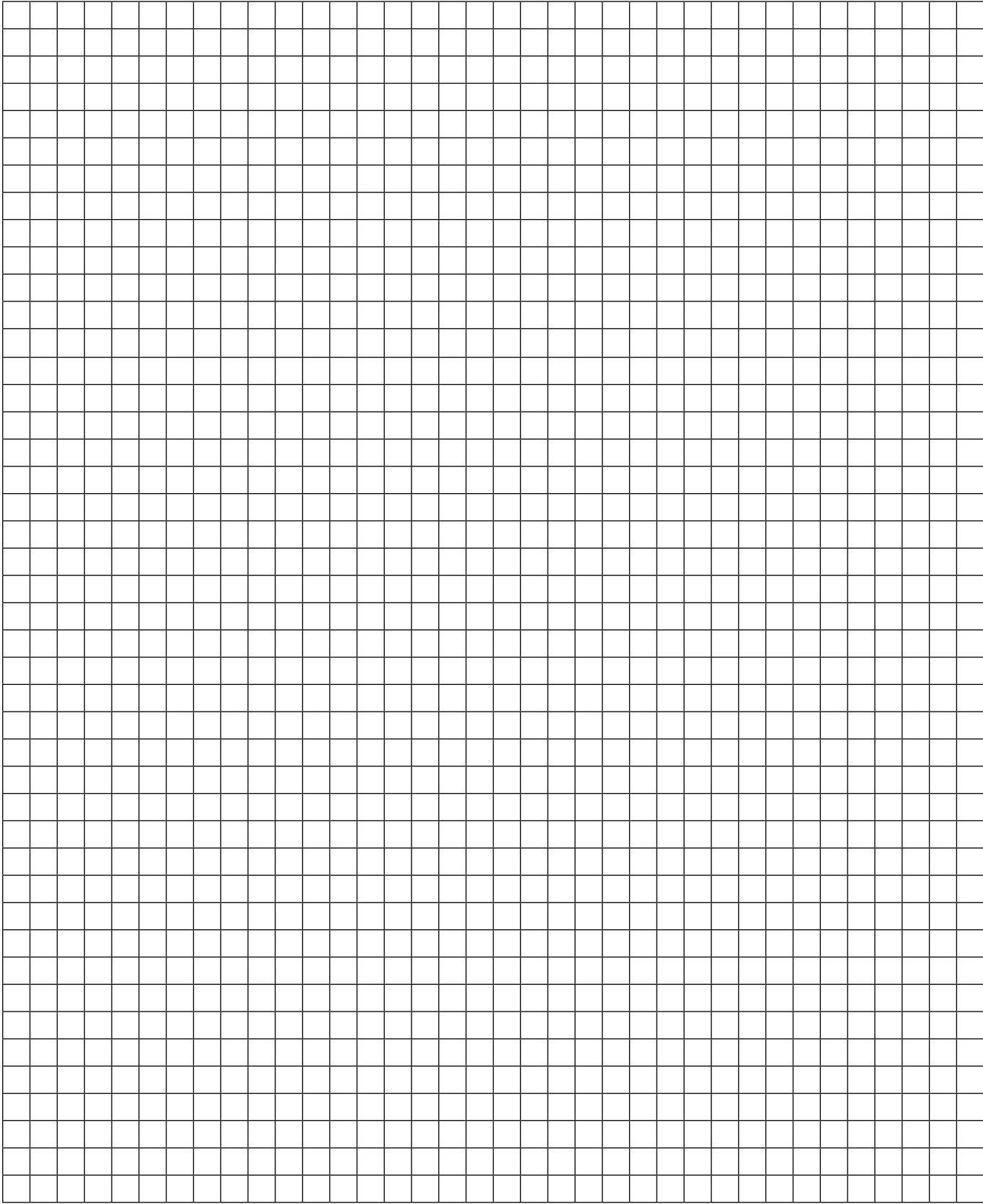

Cable drag chain systems

HeavyLine

MP 62.2

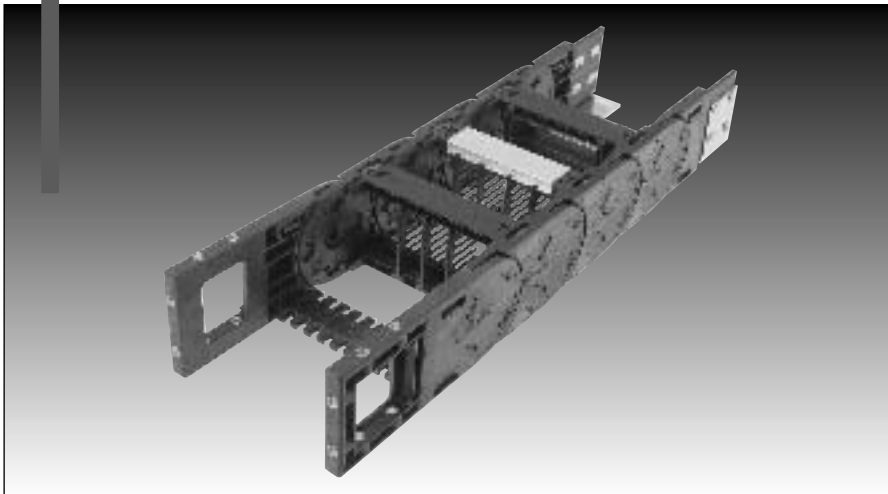



MP 62.2 - HeavyLine 2nd generation

Order variants

Style (order code)						
Configuration (order code) * = standard						
Radius (order code) <small>The radii can be combined with any internal width</small>						
in inch						
Internal width (order code)						
in inch						
Outside width in inch						
MP 62.2 118	5.91	4.65	118			
MP 62.2 143	6.89	5.63	143			
MP 62.2 168	7.87	6.61	168			
MP 62.2 193	8.86	7.60	193			
MP 62.2 218	9.84	8.58	218			
MP 62.2 243	10.38	9.57	243			
MP 62.2 268	11.81	10.55	268			
MP 62.2 293	12.80	11.54	293			
MP 62.2 318	13.78	12.52	318			
MP 62.2 343	14.76	13.50	343	5.91	150	0
MP 62.2 368	15.75	14.49	368	7.87	200	1
MP 62.2 418	17.72	16.46	418	9.84	250	2*
MP 62.2 468	19.69	18.43	468	11.81	300	3*
MP 62.2 518	21.65	20.39	518	13.78	350	4
MP 62.2 xxx	inside + 1.26	>4.65 -23.62	Alu	15.75	400	5
				19.69	500	6
						7
						8
						9

Order-Number:

Configuration:

- 0 PA crossbar every link; w/bias
- 1 PA crossbar every link; w/o bias
- 2* PA crossbar EOL; w/bias
- 3* PA crossbar EOL; w/o bias
- 4 AL crossbar every link; w/bias
- 5 AL crossbar every link; w/o bias
- 6 AL crossbar EOL; w/bias
- 7 AL crossbar EOL; w/o bias
- 9 Custom version

Style:

- 0 Standard (PA/black)
- 5 Polypropylene (PP/blue)
- 7 ESD (PA/light gray)
- 9 Custom version

Sample order:
0622 118 150 0000

Internal width = 4.65 in (118 mm)
Radius = 5.91 in (150 mm)
Configuration = 0
Style = 0

Ideal operating conditions:

- Extreme accelerations
- Extreme speeds
- Very high additional loads
- Both sides must be opened
- Aluminum frame bridge in variable lengths
- Flexible internal separation
- Version with/without bias

Alternative chain type:

- MP 65 G closed series
- MP 66 easier to use
- MP 62.1 greater unsupported length

Features

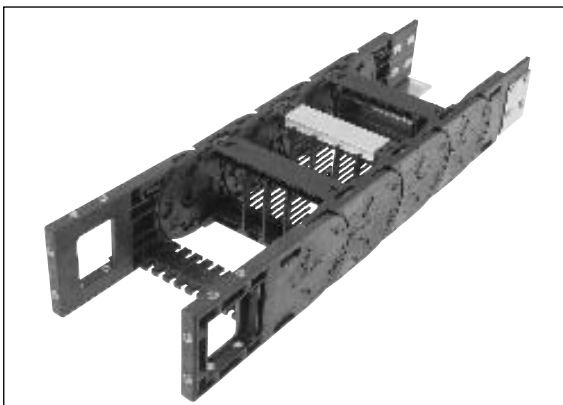

Chain bracket, can be fastened on three sides



Crossbar strain relief can be integrated into chain bracket



Side links with CLICK lock for easy opening



ESD cable drag chains for use in areas at risk of explosion



Aluminum frame bridges with integrated lock grid in variable lengths



Chain bracket with variably positionable metal angle



Crossbar/cover can be removed from inside and outside flexure curve



Radii with or without bias (RV/RK)



Reverse radius combinations



Foldable shelf system for reliable cable guidance

Technical data

Chain link dimensions (inch) (mm)

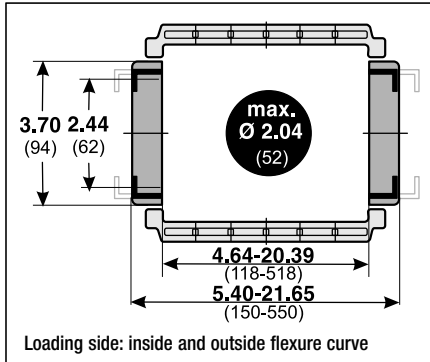

Material characteristics standard (PA/black)

Operating temperature: -22 to 248° F
 Gliding friction factor: 0.30
 Static friction factor: 0.45
 Fire classification: VDE 0304 IIC; UL94 HB

Other material properties on request

Technical specifications

Travel distance, gliding, L_g : 492.13 ft
 Travel distance, self-supporting, L_s : see diagram
 Travel distance, vertical, hanging, L_{vh} : 393.70 ft
 Travel distance, vertical, upright, L_{vu} : 19.69 ft
 Rotated 90°, self-supporting, L_{90r} : 13.12 ft
 Speed, gliding, V_g : 16.40 ft/s
 Speed, self-supporting, V_s : 65.62 ft/s
 Acceleration, gliding, a_g : 82.02 ft/s²
 Acceleration, self-supporting, a_s : 131.23 ft/s²

Self-supporting length

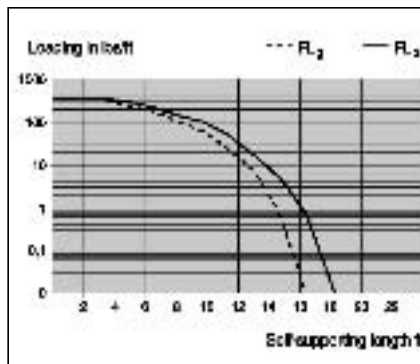
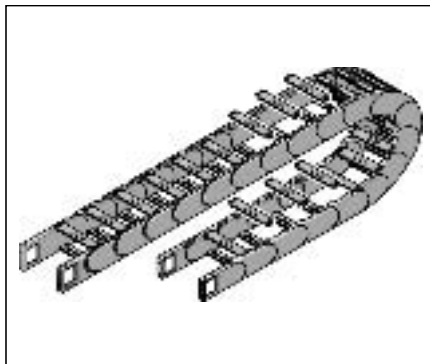

FL_g:
 Ideal installation situation for high stresses at the limit of the max. travel parameters. In this range the chain upper run is still biased, straight or has a max. sag of 0.39 – 1.97 in (10 – 50 inch) depending on the type of chain.

FL_s:
 Satisfactory installation position for many applications working in the lower to middle range of the max. travel parameters. Depending on the chain type, the sag of the chain upper run is >0.39 – 1.97 in (>10 – 50 inch) but certainly less than the max. sag.

If the sag is greater than FL_s, the arrangement is unsuitable and should be avoided. Please choose a more stable Murrplastik cable drag chain.

Determining the chain length

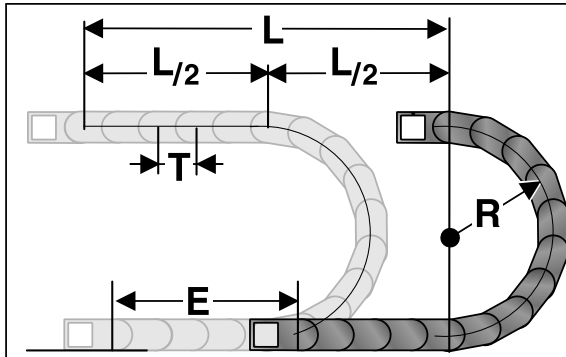

L = Travel distance
 R = Radius
 T = Pitch
 E = Distance between entry point and middle of travel distance

Determining the chain length

$$\text{Length} = \frac{L}{2} + \pi \times R + E$$

≈ 1 ft(m) chain = 3(10) links each 3.94 in (100 mm)

The fixed point of the cable drag chain should be connected in the middle of the travel distance. This arrangement gives the shortest connection between the fixed point and the moving point and thus the most efficient chain length.

Installation dimensions (in inch)

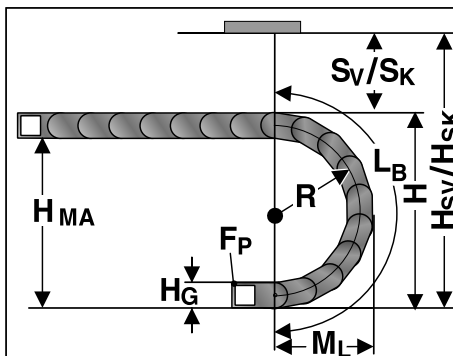

Radius R	5.91	7.87	9.84	11.81	13.78	15.75	19.69
Outside height of chain link (H_o)	3.70	3.70	3.70	3.70	3.70	3.70	3.70
Height of bend (H)	16.69	20.63	24.57	28.50	32.44	36.38	44.25
Height of moving end connection (H_{ma})	12.99	16.93	20.87	24.80	28.74	32.68	40.55
Safety margin with bias (S_v)	1.97	1.97	1.97	1.97	1.97	1.97	1.97
Installation height with bias (H_{sv})	18.66	22.60	26.54	30.47	34.41	38.35	45.16
Safety margin without bias (S_k)	0.79	0.79	0.79	0.79	0.79	0.79	0.79
Installation height without bias (H_{sk})	17.48	21.12	25.35	29.29	33.24	37.17	45.04
Arc projection (M_l)	12.28	14.25	16.22	18.19	20.16	22.13	26.06
Bend length (L_b)	30.16	36.34	42.52	48.70	54.88	61.06	73.43



MP 62.2 - HeavyLine 2nd generation

Chain bracket

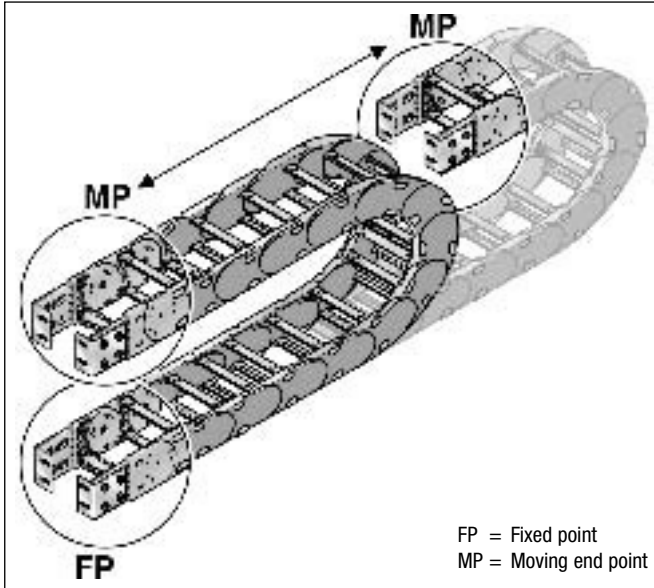

Flexible chain bracket

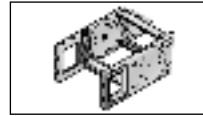

Flexible

Chain bracket angle

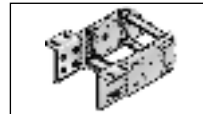

Top/Outside



Front/Outside

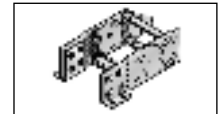

Bottom/Outside

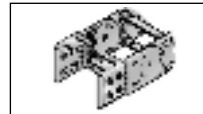

Top/Inside

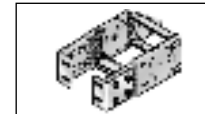

Front/Inside

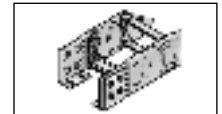

Bottom/Inside

Flexible chain bracket

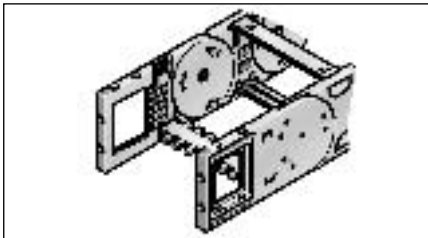

KA 62...

Type	Order no.	Version	Pack qty.
KA 62-FB Female end	0620000056	with bushing	1
KA 62-FB Male end	0620000057	with bushing	1
KA 62-FG Female end	0620000058	with thread	1
KA 62-FG Male end	0620000059	with thread	1

This chain bracket offers universal connection options (top, bottom and front) and is attached to the ends of the chain like a side link. This allows the chain to move right up to the bracket. Each chain requires one male and one female bracket. Use M8 screws for connecting. Extrusion-coated metal bushings with either a through-hole (-FB) or a threaded hole (-FG) ensure the permanent, high-strength transmission of even extreme forces onto the cable drag chain.

Chain bracket angle

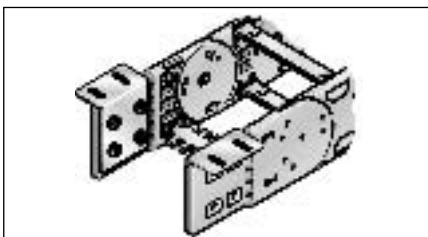

KA 62

Type	Order no.	Pack qty.
KA 62 Female end	0620000050	1
KA 62 Male end	0620000051	1

This chain bracket offers universal connection options (top, bottom and front) and is attached to the ends of the chain like a side link. This allows the chain to move right up to the bracket. Each chain requires one male and one female bracket. Use M8 screws for connecting. Metal inserts (supplied) help to minimise the cold flow properties. This is an enormous advantage, guaranteeing the smooth transfer of high loads to the chain.

Flexible chain bracket

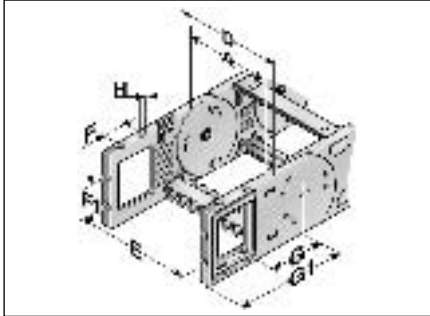

Flexible with through-hole

Type	A inch	D inch	E inch	F inch	F1 inch	G inch	G1 inch	H Ø inch
KA 62-FB	4.65	5.91	5.31	1.38	1.77	4.21	6.75	0.33
KA 62-FB	5.63	6.89	6.30	1.38	1.77	4.21	6.75	0.33
KA 62-FB	6.61	7.87	7.28	1.38	1.77	4.21	6.75	0.33
KA 62-FB	7.60	8.86	8.27	1.38	1.77	4.21	6.75	0.33
KA 62-FB	8.58	9.84	9.25	1.38	1.77	4.21	6.75	0.33
KA 62-FB	9.57	10.83	10.24	1.38	1.77	4.21	6.75	0.33
KA 62-FB	10.55	11.81	11.22	1.38	1.77	4.21	6.75	0.33
KA 62-FB	11.54	9.25	12.20	1.38	1.77	4.21	6.75	0.33
KA 62-FB	12.52	13.78	13.19	1.38	1.77	4.21	6.75	0.33
KA 62-FB	13.50	14.76	14.17	1.38	1.77	4.21	6.75	0.33
KA 62-FB	14.49	13.23	15.16	1.38	1.77	4.21	6.75	0.33
KA 62-FB	16.46	17.72	17.13	1.38	1.77	4.21	6.75	0.33
KA 62-FB	18.43	19.69	19.09	1.38	1.77	4.21	6.75	0.33
KA 62-FB	20.39	21.65	21.06	1.38	1.77	4.21	6.75	0.33
KA 62-FB	variable	A+1.26	A+0.67	1.38	1.77	4.21	6.75	0.33

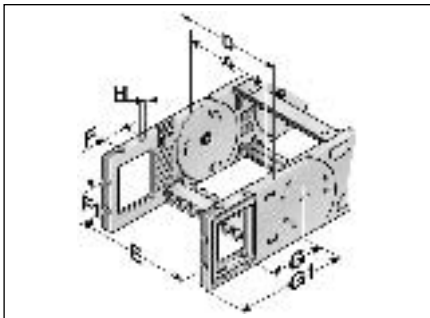

Flexible with threaded bushing

Type	A inch	D inch	E inch	F inch	F1 inch	G inch	G1 inch	H
KA 62-FG	4.65	5.91	5.31	1.38	1.77	4.21	6.75	M8
KA 62-FG	5.63	6.89	6.30	1.38	1.77	4.21	6.75	M8
KA 62-FG	6.61	7.87	7.28	1.38	1.77	4.21	6.75	M8
KA 62-FG	7.60	8.86	8.27	1.38	1.77	4.21	6.75	M8
KA 62-FG	8.58	9.84	9.25	1.38	1.77	4.21	6.75	M8
KA 62-FG	9.57	10.83	10.24	1.38	1.77	4.21	6.75	M8
KA 62-FG	10.55	11.81	11.22	1.38	1.77	4.21	6.75	M8
KA 62-FG	11.54	9.25	12.20	1.38	1.77	4.21	6.75	M8
KA 62-FG	12.52	13.78	13.19	1.38	1.77	4.21	6.75	M8
KA 62-FG	13.50	14.76	14.17	1.38	1.77	4.21	6.75	M8
KA 62-FG	14.49	13.23	15.16	1.38	1.77	4.21	6.75	M8
KA 62-FG	16.46	17.72	17.13	1.38	1.77	4.21	6.75	M8
KA 62-FG	18.43	19.69	19.09	1.38	1.77	4.21	6.75	M8
KA 62-FG	20.39	21.65	21.06	1.38	1.77	4.21	6.75	M8
KA 62-FG	variable	A+1.26	A+0.67	1.38	1.77	4.21	6.75	M8



MP 62.2 - HeavyLine 2nd generation

Chain bracket angle

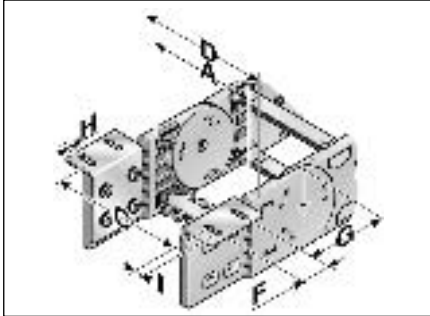

Bottom and top/outside

Type	A inch	C inch	D inch	F inch	G inch	H Ø inch	I inch
KA 62	4.65	6.38	5.91	1.77	4.02	0.35	0.59
KA 62	5.63	7.36	6.89	1.77	4.02	0.35	0.59
KA 62	6.61	8.35	7.87	1.77	4.02	0.35	0.59
KA 62	7.60	9.33	8.86	1.77	4.02	0.35	0.59
KA 62	8.58	10.31	9.84	1.77	4.02	0.35	0.59
KA 62	9.57	11.30	10.83	1.77	4.02	0.35	0.59
KA 62	10.55	12.28	11.81	1.77	4.02	0.35	0.59
KA 62	11.54	13.27	12.80	1.77	4.02	0.35	0.59
KA 62	12.52	14.25	13.78	1.77	4.02	0.35	0.59
KA 62	13.50	15.24	14.76	1.77	4.02	0.35	0.59
KA 62	14.49	16.22	15.75	1.77	4.02	0.35	0.59
KA 62	16.46	18.19	17.72	1.77	4.02	0.35	0.59
KA 62	18.43	20.16	19.69	1.77	4.02	0.35	0.59
KA 62	20.39	22.13	21.65	1.77	4.02	0.35	0.59
KA 62	variable	A+1.73	A+1.26	1.77	4.02	0.35	0.59

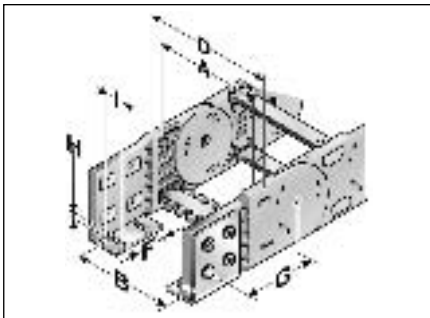

Bottom and top/inside

Type	A inch	B inch	D inch	F inch	G inch	H Ø inch	I inch
KA 62	4.65	4.17	5.91	1.77	4.02	0.35	0.59
KA 62	5.63	5.16	6.89	1.77	4.02	0.35	0.59
KA 62	6.61	6.14	7.87	1.77	4.02	0.35	0.59
KA 62	7.60	7.13	8.86	1.77	4.02	0.35	0.59
KA 62	8.58	8.11	9.84	1.77	4.02	0.35	0.59
KA 62	9.57	9.09	10.83	1.77	4.02	0.35	0.59
KA 62	10.55	10.08	11.81	1.77	4.02	0.35	0.59
KA 62	11.54	11.06	12.80	1.77	4.02	0.35	0.59
KA 62	12.52	12.13	13.78	1.77	4.02	0.35	0.59
KA 62	13.50	13.03	14.76	1.77	4.02	0.35	0.59
KA 62	14.49	14.02	15.75	1.77	4.02	0.35	0.59
KA 62	16.46	15.98	17.72	1.77	4.02	0.35	0.59
KA 62	18.43	17.95	19.69	1.77	4.02	0.35	0.59
KA 62	20.39	19.92	21.65	1.77	4.02	0.35	0.59
KA 62	variable	A-0.47	A+1.26	1.77	4.02	0.35	0.59

Chain bracket angle

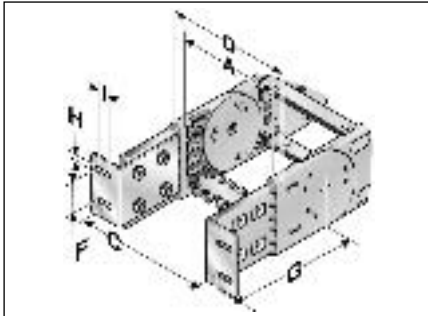

Front/Outside

Type	A inch	C inch	D inch	F inch	G inch	H Ø inch	I inch
KA 62	4.65	6.38	5.91	1.77	6.75	0.35	0.59
KA 62	5.63	7.36	6.89	1.77	6.75	0.35	0.59
KA 62	6.61	8.35	7.87	1.77	6.75	0.35	0.59
KA 62	7.60	9.33	8.86	1.77	6.75	0.35	0.59
KA 62	8.58	10.31	9.84	1.77	6.75	0.35	0.59
KA 62	9.57	11.30	10.83	1.77	6.75	0.35	0.59
KA 62	10.55	12.28	11.81	1.77	6.75	0.35	0.59
KA 62	11.54	13.27	12.80	1.77	6.75	0.35	0.59
KA 62	12.52	14.25	13.78	1.77	6.75	0.35	0.59
KA 62	13.50	15.24	14.76	1.77	6.75	0.35	0.59
KA 62	14.49	16.22	15.75	1.77	6.75	0.35	0.59
KA 62	16.46	18.19	17.72	1.77	6.75	0.35	0.59
KA 62	18.43	20.16	19.69	1.77	6.75	0.35	0.59
KA 62	20.39	22.13	21.65	1.77	6.75	0.35	0.59
KA 62	variable	A+1.73	A+1.26	1.77	6.75	0.35	0.59

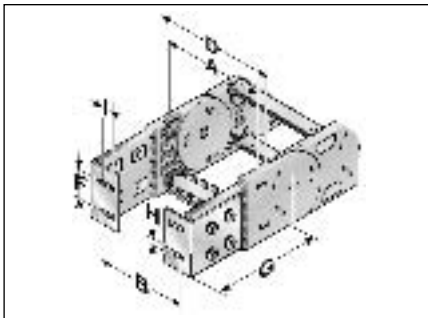

Front/Inside

Type	A inch	B inch	D inch	F inch	G inch	H Ø inch	I inch
KA 62	4.65	4.17	5.91	1.77	6.75	0.35	0.59
KA 62	5.63	5.16	6.89	1.77	6.75	0.35	0.59
KA 62	6.61	6.14	7.87	1.77	6.75	0.35	0.59
KA 62	7.60	7.13	8.86	1.77	6.75	0.35	0.59
KA 62	8.58	8.11	9.84	1.77	6.75	0.35	0.59
KA 62	9.57	9.09	10.83	1.77	6.75	0.35	0.59
KA 62	10.55	10.08	11.81	1.77	6.75	0.35	0.59
KA 62	11.54	11.06	12.80	1.77	6.75	0.35	0.59
KA 62	12.52	12.13	13.78	1.77	6.75	0.35	0.59
KA 62	13.50	13.03	14.76	1.77	6.75	0.35	0.59
KA 62	14.49	14.02	15.75	1.77	6.75	0.35	0.59
KA 62	16.46	15.98	17.72	1.77	6.75	0.35	0.59
KA 62	18.43	17.95	19.69	1.77	6.75	0.35	0.59
KA 62	20.39	19.92	21.65	1.77	6.75	0.35	0.59
KA 62	variable	A-0.47	A+1.26	1.77	6.75	0.35	0.59



Assembly instruction flexible chain bracket

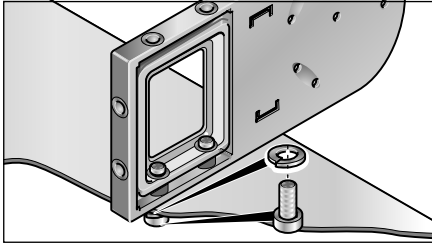

Chain bracket with threaded bushing

Brass bushings guarantee long-lasting fastening without cold flow in the plastic.

Version KA-FB:

Integrated through-hole fastened down using screw and nut.

Version KA-FG:

Built-in threads allow for quick and easy on-site mounting, since a screw, including a retaining washer where necessary, is sufficient.

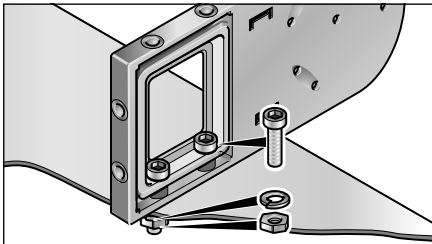

Chain bracket with bushing

Separator

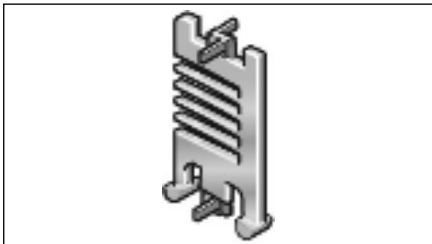

Separator

Type	Order no.	Designation	Lock grid spacing inch	Pack qty.
TR 62	062000009200	Separator	0.20	1

We recommend that separators be used if multiple round cables or conduits with differing diameters are to be installed. An offset configuration of the separators is advisable.

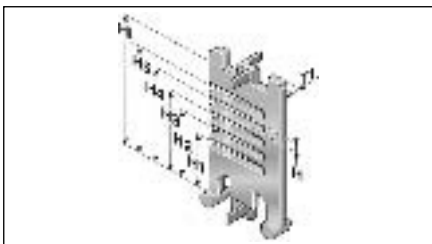

Separator

Type	T1 inch	H inch	H1 inch	H2 inch	H3 inch	H4 inch	H5 inch	H1 inch
TR 62	0.14	0.22	0.58	0.91	1.24	1.56	1.89	2.44

Shelving system

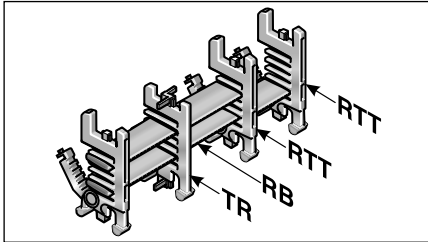

Shelving system

Type	Order no.	Designation	Width inch	Lock grid spacing inch	Pack qty.
RB 056-7	100000005600	RB 056-7 Shelf	2.20	0.20	1
RB 066-7	100000006600	RB 066-7 Shelf	2.60	0.20	1
RB 081-7	100000008100	RB 081-7 Shelf	3.19	0.20	1
RB 106-7	100000010600	RB 106-7 Shelf	4.17	0.20	1
RB 116-7	100000011600	RB 116-7 Shelf	4.57	0.20	1
RB 166-7	100000016600	RB 166-7 Shelf	6.54	0.20	1
RB 216-7	100000021600	RB 216-7 Shelf	8.50	0.20	1
RTT 62	100090622000	RTT 62 Shelf support, divisible		0.20	1

In connection with at least two shelf supports (RTT) the shelf becomes a shelving system. The additional levels prevent cables from criss-crossing and therefore destroying each other, while also avoiding excessive friction. The shelving system may be pre-assembled on request.

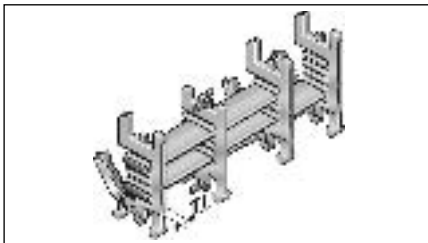

Shelving system

Type	TI inch
RTT 62	0.31

Crossbar connector

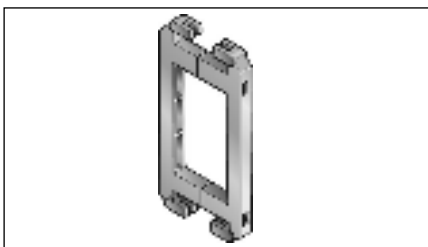

Crossbar connector

Type	Order no.	Designation	Pack qty.
RSV 62	062000009600	RSV 62 Crossbar connector	1
RSV 62 Alu	062000009800	RSV 62 Crossbar connector for aluminum crossbridges	1

For frame bridges wider than 9.69 in (246 mm), we recommend the use of crossbar connectors. These prevent deformation to the frame bridge under large amounts of additional weight of the chain assembly.

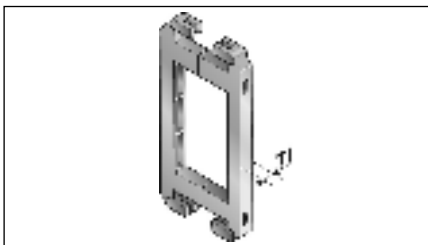

Type	TI inch
RSV 62	0.31
RSV 62 Alu	0.31



Crossbar strain relief plate RS-ZL

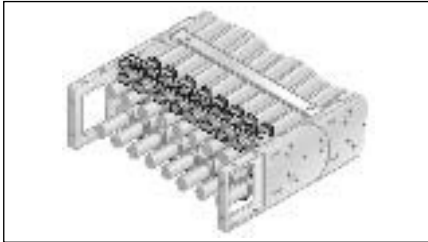

Crossbar strain relief plate RS-ZL

Type	Order no.	For internal width inch	Pack qty.
RS-ZL 118-7	072011800010	4.65	1
RS-ZL 143-7	072014300010	5.63	1
RS-ZL 168-7	072016800010	6.61	1
RS-ZL 193-7	072019300010	7.60	1
RS-ZL 218-7	072021800010	8.58	1
RS-ZL 243-7	072024300010	9.57	1

Fixed integrated frame bridge strain relief plates in the chain brackets. Accommodated to all widths of the frame ridges, up to 9.57 in (243 mm) in size. May be assembled on the inside and outside flexure curves at both chain endings.

Strain relief type BAK

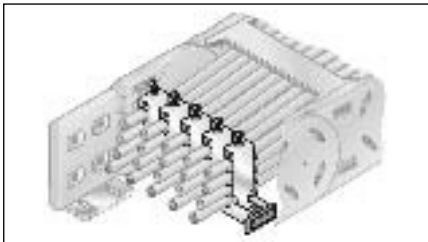

Strain relief with hooped clamp

Type	Order no.	Designation	Ø inch	Number of seats	Pack qty.
C-rail	81661610	C-profile rail			1
BA 12	81661036	BA 12 Hooped clamp	0.35–0.47	1	1
BAK 14	81661002	BAK 14 Hooped clamp	0.24–0.55	1	1
BAK 18	81661004	BAK 18 Hooped clamp	0.55–0.71	1	1
BAK 22	81661006	BAK 22 Hooped clamp	0.71–0.87	1	1
BAK 26	81661008	BAK 26 Hooped clamp	0.87–1.02	1	1
BAK 30	81661010	BAK 30 Hooped clamp	1.02–1.18	1	1
BAK 34	81661000	BAK 34 Hooped clamp	1.18–1.34	1	1
BAK 38	81661044	BAK 38 Hooped clamp	1.34–1.50	1	1
BAK 42	81661032	BAK 42 Hooped clamp	1.50–1.65	1	1
BAK 46	81661050	BAK 46 Hooped clamp	1.65–1.81	1	1
BA 12/2	81661038	BA 12/2 Hooped clamp	0.35–0.47	2	1
BAK 14/2	81661012	BAK 14/2 Hooped clamp	0.39–0.55	2	1
BAK 18/2	81661014	BAK 18/2 Hooped clamp	0.55–0.71	2	1
BAK 22/2	81661016	BAK 22/2 Hooped clamp	0.71–0.87	2	1
BAK 26/2	81661018	BAK 26/2 Hooped clamp	0.87–1.02	2	1
BAK 30/2	81661048	BAK 30/2 Hooped clamp	1.02–1.18	2	1
BAK 34/2	81661044	BAK 34/2 Hooped clamp	1.18–1.34	2	1
BAK 38/2	81661046	BAK 38/2 Hooped clamp	1.34–1.50	2	1
BAK 42/2	81661034	BAK 42/2 Hooped clamp	1.50–1.65	2	1
BAK 12/3	81661020	BAK 12/3 Hooped clamp	0.35–0.47	3	1
BAK 14/3	81661022	BAK 14/3 Hooped clamp	0.47–0.55	3	1
BAK 16/3	81661024	BAK 16/3 Hooped clamp	0.55–0.63	3	1
BAK 18/3	81661026	BAK 18/3 Hooped clamp	0.63–0.71	3	1
BAK 20/3	81661028	BAK 20/3 Hooped clamp	0.71–0.79	3	1
BAK 22/3	81661030	BAK 22/3 Hooped clamp	0.79–0.87	3	1

Fixed integrated strain relief in the chain connections. Available in all widths (also individual widths for aluminum frame ridges). May be assembled on the inside and outside flexure curves at both chain endings. Chain content is secured through hooped clamps that are available in different sizes. Material: Galvanized steel.

When ordering please indicate the type of chain and internal width.

Reverse radius

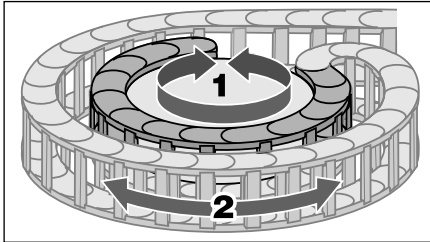

Rotating movement

Type	Order no.	Radius inch	Reverse radius inch	Pack qty.
SR 62.1 (RÜ300/R300) left	62200030060	11.81	11.81	1
SR 62.1 (RÜ300/R300) right	62200030062	11.81	11.81	1

Side links with radius forward (R) and radius backward (Rü) allow for movement in two directions. This is intended for rotating movements and lowered chain brackets.

Note: This type of chain has different chain links for the left or right side!

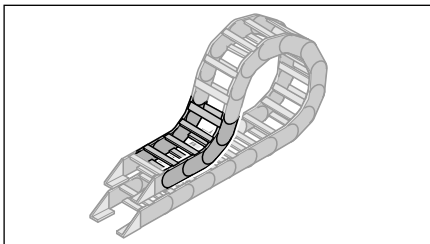

lowered chain bracket



MP 62.2 - Accessories

Assembly Disassembly

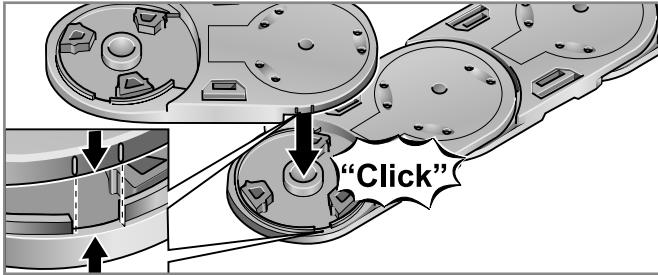

Step 1

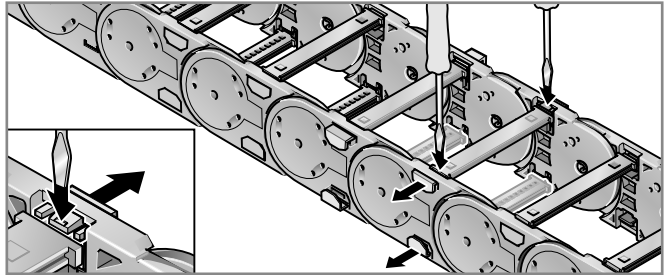

Step 1

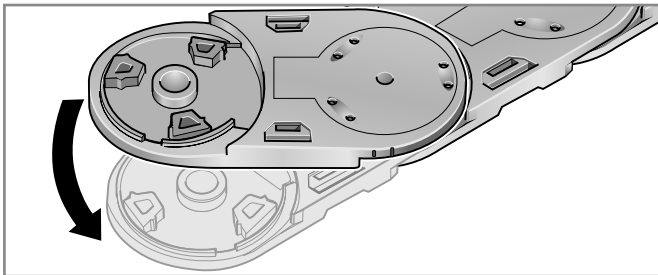

Step 2

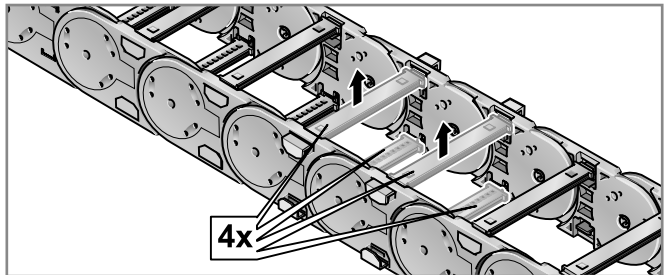

Step 2

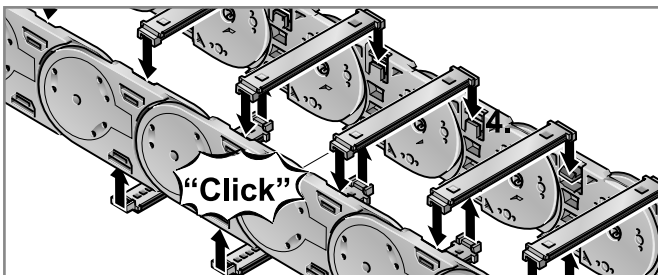

Step 3

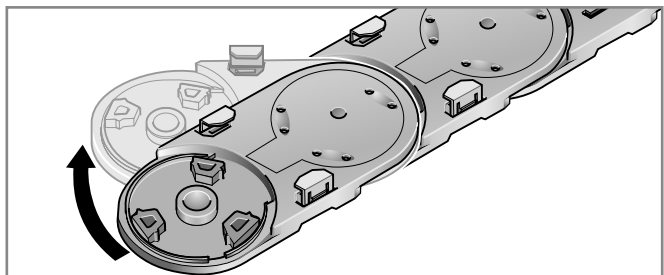

Step 3

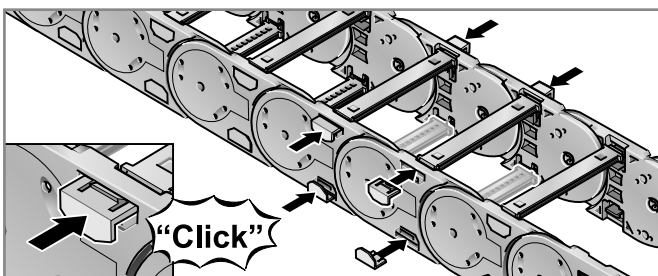

Step 4

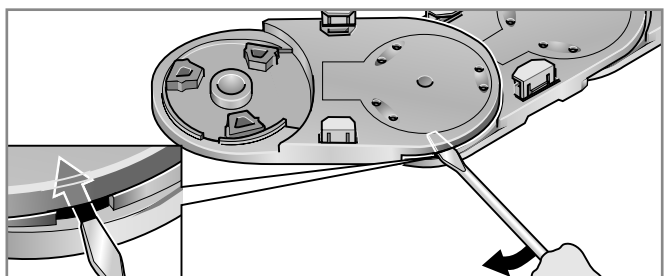

Step 4

Cable drag chain systems

HeavyLine

MP 72

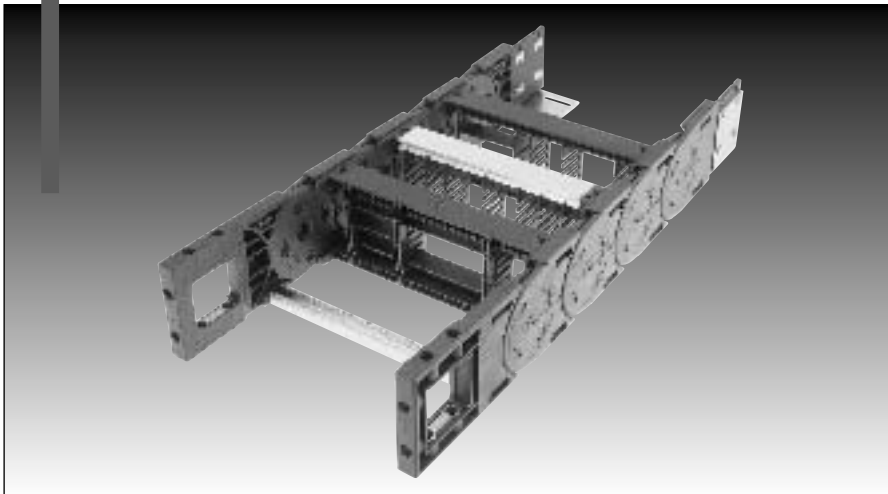



MP 72 - HeavyLine

Order variants

Style (order code)						
Configuration (order code) * = standard						
Radius (order code) <small>The radii can be combined with any internal width</small>						
in inch						
Internal width (order code)						
in inch						
Outside width (order code)						
in inch						
MP 72 118	5.91	4.65	118			
MP 72 143	6.89	5.63	143			
MP 72 168	7.87	6.61	168			
MP 72 193	8.86	7.60	193			
MP 72 218	9.84	8.58	218			
MP 72 243	10.38	9.57	243			
MP 72 268	11.81	10.55	268			
MP 72 293	12.80	11.54	293			
MP 72 318	13.78	12.52	318			
MP 72 343	14.76	13.50	343			
MP 72 368	15.75	14.49	368	5.91	150	
MP 72 418	17.72	16.46	418	7.87	200	0
MP 72 468	19.69	18.43	468	9.84	250	2*
MP 72 518	21.65	20.39	518	11.81	300	4
MP 72 xxx	inside	>4.65		15.75	400	6
	+ 1.26	-23.62	Alu	19.69	500	9
						0
						9

Order-Number:

Configuration:

- 0 PA crossbar every link; w/bias
- 2* PA crossbar EOL; w/bias
- 4 AL crossbar every link; w/bias
- 6 AL crossbar EOL; w/bias
- 9 Custom version

Style:

- 0 Standard (PA/black)
- 9 Custom version

Sample order:

0720 118 150 0000

Internal width = 4.65 in (118 mm)
 Radius = 5.91 in (150 mm)
 Configuration = 0
 Style = 0

Ideal operating conditions:

- Extreme accelerations
- Extreme speeds
- Extreme self-supporting lengths
- Very high additional loads
- Both sides must be opened
- Aluminum frame bridge in variable lengths
- Flexible internal separation
- Rotated 90° unsupported
- Rotated 90° horizontal
- Version with/without bias

Alternative chain type:

- MP 62.2/MP 82.2 simpler assembly

Features

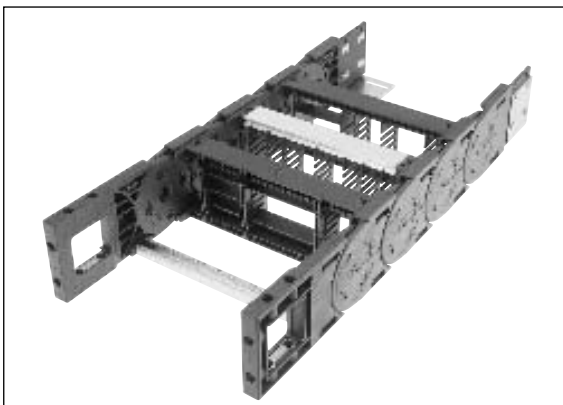

Chain bracket with variably positionable metal angle



Crossbar/cover can be removed from inside and outside flexure curve



Reverse radius combinations



Foldable shelf system for reliable cable guidance



Crossbar strain relief can be integrated into chain bracket



Radii with or without bias (RV/RK)



Aluminum frame bridges with integrated lock grid in variable lengths



Crossbar connector for securing of large frame bridge widths

Technical data

Chain link dimensions (inch) (mm)

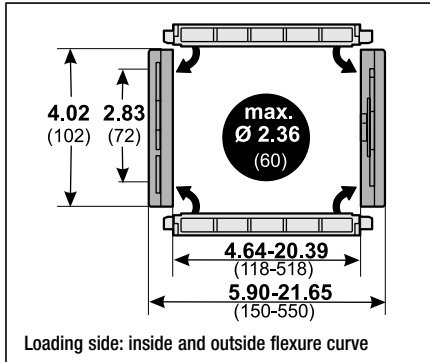

Material characteristics standard (PA/black)

Operating temperature: -22 to 248° F
 Gliding friction factor: 0.30
 Static friction factor: 0.45
 Fire classification: Based on UL94 HB

Other material properties on request

Technical specifications

Travel distance, gliding, L_g : 492.13 ft
 Travel distance, self-supporting, L_s : see diagram
 Travel distance, vertical, hanging, L_{vs} : 393.70 ft
 Travel distance, vertical, upright, L_{vs} : 19.69 ft
 Rotated 90°, self-supporting, L_{90r} : 19.69 ft
 Speed, gliding, V_g : 16.40 ft/s
 Speed, self-supporting, V_r : 65.62 ft/s
 Acceleration, gliding, a_g : 82.02 ft/s²
 Acceleration, self-supporting, a_s : 131.23 ft/s²

Self-supporting length

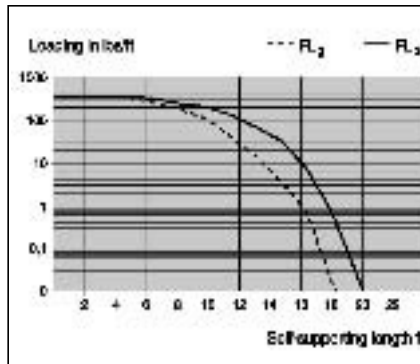
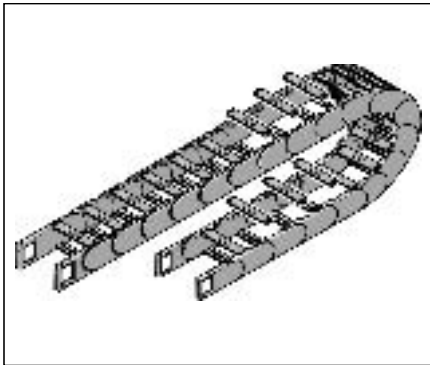

FL₁:
 Ideal installation situation for high stresses at the limit of the max. travel parameters. In this range the chain upper run is still biased, straight or has a max. sag of 0.39 – 1.97 in (10 – 50 mm) depending on the type of chain.

FL₂:
 Satisfactory installation position for many applications working in the lower to middle range of the max. travel parameters. Depending on the chain type, the sag of the chain upper run is >0.39 – 1.97 in (>10 – 50 mm) but certainly less than the max. sag.

If the sag is greater than FL₂, the arrangement is unsuitable and should be avoided. Please choose a more stable Murrplastik cable drag chain.

Determining the chain length

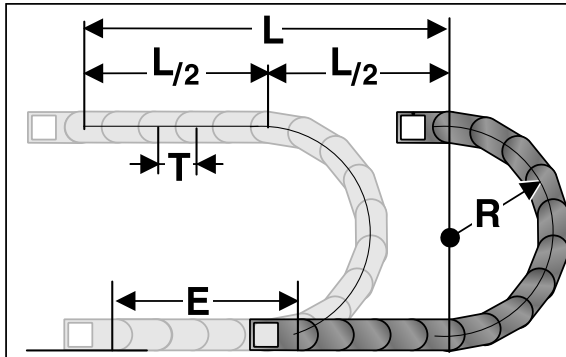

Determining the chain length

$$\text{Length} = \frac{L}{2} + \pi \times R + E$$

$$\approx 1 \text{ ft(m) chain} = 3(10) \text{ links each } 3.94 \text{ in (100 mm)}$$

The fixed point of the cable drag chain should be connected in the middle of the travel distance. This arrangement gives the shortest connection between the fixed point and the moving point and thus the most efficient chain length.

Installation dimensions (in inch)

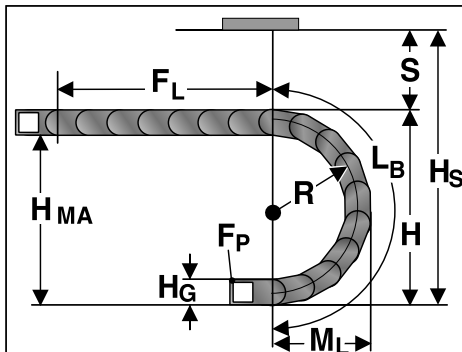

Radius R	5.91	7.87	9.84	11.81	15.75	19.69
Outside height of chain link (H_0)	4.02	4.02	4.02	4.02	4.02	4.02
Height of bend (H)	16.61	20.55	24.49	28.43	36.30	44.17
Height of moving end connection (H_{MA})	12.60	16.54	20.47	24.41	32.28	40.16
Safety margin (S)	0.79	0.79	0.79	0.79	0.79	0.79
Installation height (H_S)	17.40	21.34	25.28	29.21	37.09	44.96
Arc projection (M_L)	12.24	14.21	16.18	18.15	22.09	26.02
Bend length (L_b)	30.04	36.22	42.40	48.58	60.94	73.31



Chain bracket

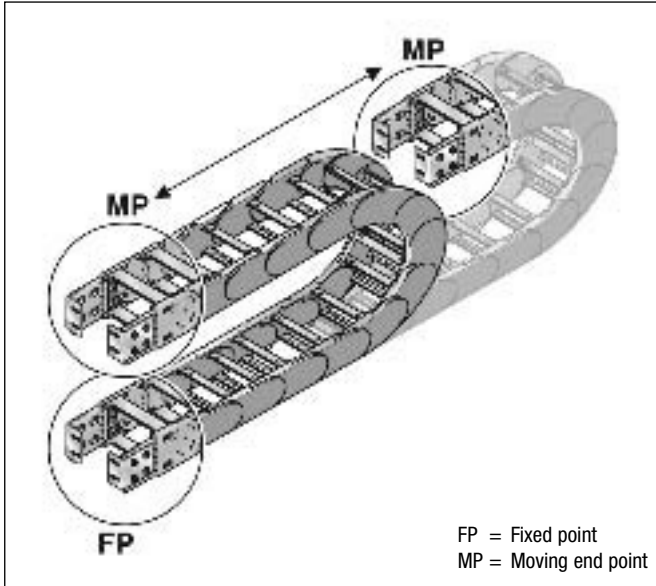

Flexible chain bracket

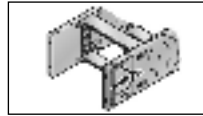

Flexible

Chain bracket angle

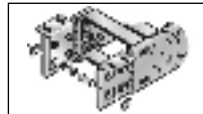

Top/Outside

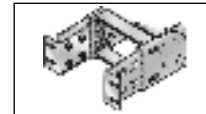

Front/Outside

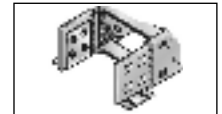

Bottom/Outside

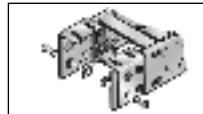

Top/Inside

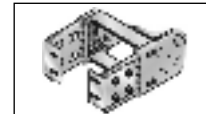

Front/Inside

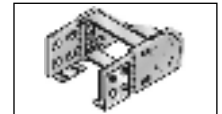

Bottom/Inside

Flexible chain bracket

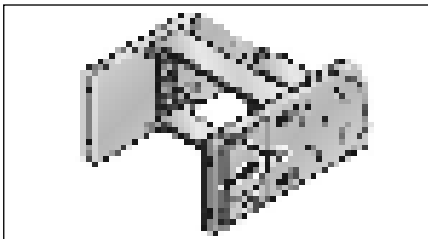

KA 72-F

Type	Order no.	Pack qty.
KA 72-F Female end	0720000054	1
KA 72-F male end	0720000055	1

This chain bracket offers universal connection options (top, bottom and front) and is attached to the ends of the chain like a side link. This allows the chain to move right up to the bracket. Each chain requires one male and one female bracket. Use M10 screws for connecting. Metal inserts (supplied) help to minimise the cold flow properties. This is an enormous advantage, guaranteeing the smooth transfer of high loads to the chain.

Chain bracket angle

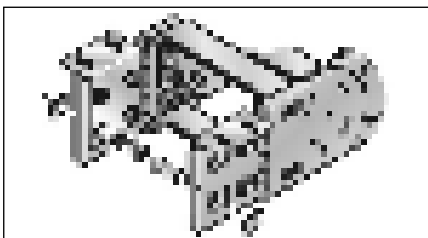

KA 72

Type	Order no.	Pack qty.
KA 72 Female end	0720000050	1
KA 72 Male end	0720000051	1

There are several options regarding the chain bracket. The fixed-point bracket (inside/bottom) and the moving end bracket (inside/top) are supplied as standard. However, any other combination can be supplied upon request. The chain bracket is fastened at the end like a side link. This enables the chain to move right up to the bracket. Each chain requires one male and one female bracket. Fasten the connections with M8 screws.

Flexible chain bracket

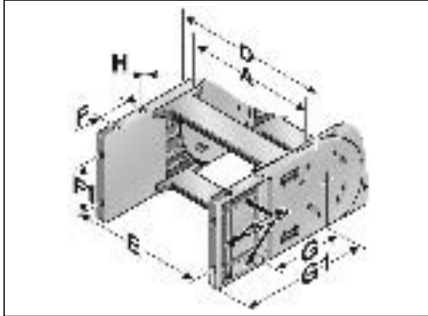

Flexible

Type	A inch	D inch	E inch	F inch	F1 inch	G inch	G1 inch	H Ø inch
KA 72-F	4.65	5.91	5.08	1.38	1.77	4.21	6.75	0.43
KA 72-F	5.63	6.89	6.06	1.38	1.77	4.21	6.75	0.43
KA 72-F	6.61	7.87	7.05	1.38	1.77	4.21	6.75	0.43
KA 72-F	7.60	8.86	8.03	1.38	1.77	4.21	6.75	0.43
KA 72-F	8.58	9.84	9.02	1.38	1.77	4.21	6.75	0.43
KA 72-F	9.57	10.83	10.00	1.38	1.77	4.21	6.75	0.43
KA 72-F	10.55	11.81	10.98	1.38	1.77	4.21	6.75	0.43
KA 72-F	11.54	12.80	11.97	1.38	1.77	4.21	6.75	0.43
KA 72-F	12.52	13.78	12.95	1.38	1.77	4.21	6.75	0.43
KA 72-F	13.50	14.76	13.94	1.38	1.77	4.21	6.75	0.43
KA 72-F	14.49	15.75	14.92	1.38	1.77	4.21	6.75	0.43
KA 72-F	16.46	17.72	16.89	1.38	1.77	4.21	6.75	0.43
KA 72-F	18.43	19.69	18.86	1.38	1.77	4.21	6.75	0.43
KA 72-F	20.39	21.65	20.83	1.38	1.77	4.21	6.75	0.43
KA 72-F	variable	A+1.26	A+0.43	1.38	1.77	4.21	6.75	0.43

Chain bracket angle

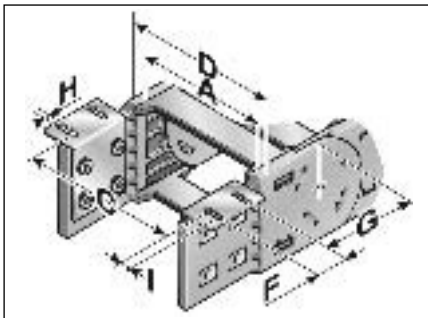

Bottom and top/outside

Type	A inch	C inch	D inch	F inch	G inch	H Ø inch	I inch
KA 72	4.65	6.54	5.91	1.77	4.17	0.35	1.26
KA 72	5.63	7.52	6.89	1.77	4.17	0.35	1.26
KA 72	6.61	8.50	7.87	1.77	4.17	0.35	1.26
KA 72	7.60	9.49	8.86	1.77	4.17	0.35	1.26
KA 72	8.58	10.47	9.84	1.77	4.17	0.35	1.26
KA 72	9.57	11.46	10.83	1.77	4.17	0.35	1.26
KA 72	10.55	12.44	11.81	1.77	4.17	0.35	1.26
KA 72	11.54	13.43	12.80	1.77	4.17	0.35	1.26
KA 72	12.52	14.41	13.78	1.77	4.17	0.35	1.26
KA 72	13.50	15.39	14.76	1.77	4.17	0.35	1.26
KA 72	14.49	16.38	15.75	1.77	4.17	0.35	1.26
KA 72	16.46	18.35	17.72	1.77	4.17	0.35	1.26
KA 72	18.43	20.31	19.69	1.77	4.17	0.35	1.26
KA 72	20.39	22.28	21.65	1.77	4.17	0.35	1.26
KA 72	variable	A+1.89	A+1.26	1.77	4.17	0.35	1.26



Chain bracket angle

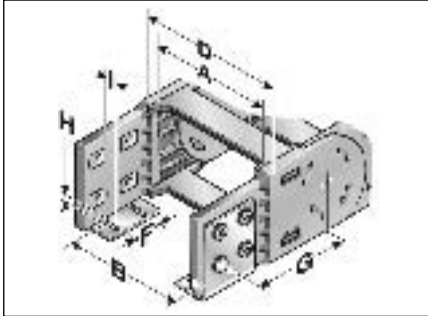

Bottom and top/inside

Type	A inch	B inch	D inch	F inch	G inch	H Ø inch	I inch
KA 72	4.65	4.02	5.91	1.77	4.17	0.35	1.26
KA 72	5.63	5.00	6.89	1.77	4.17	0.35	1.26
KA 72	6.61	5.98	7.87	1.77	4.17	0.35	1.26
KA 72	7.60	6.97	8.86	1.77	4.17	0.35	1.26
KA 72	8.58	7.95	9.84	1.77	4.17	0.35	1.26
KA 72	9.57	8.94	10.83	1.77	4.17	0.35	1.26
KA 72	10.55	9.92	11.81	1.77	4.17	0.35	1.26
KA 72	11.54	10.91	12.80	1.77	4.17	0.35	1.26
KA 72	12.52	11.89	13.78	1.77	4.17	0.35	1.26
KA 72	13.50	12.87	14.76	1.77	4.17	0.35	1.26
KA 72	14.49	13.86	15.75	1.77	4.17	0.35	1.26
KA 72	16.46	15.83	17.72	1.77	4.17	0.35	1.26
KA 72	18.43	17.80	19.69	1.77	4.17	0.35	1.26
KA 72	20.39	19.76	21.65	1.77	4.17	0.35	1.26
KA 72	variable	A-0.63	A+1.26	1.77	4.17	0.35	1.26

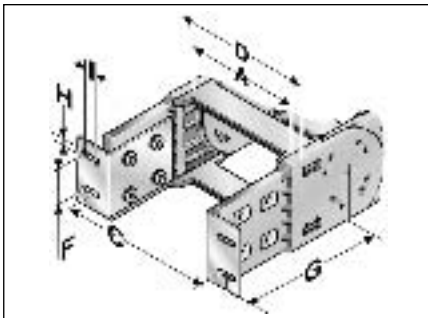

Front/Outside

Type	A inch	C inch	D inch	F inch	G inch	H Ø inch	I inch
KA 72	4.65	6.54	5.91	1.77	7.07	0.35	1.26
KA 72	5.63	7.52	6.89	1.77	7.07	0.35	1.26
KA 72	6.61	8.50	7.87	1.77	7.07	0.35	1.26
KA 72	7.60	9.49	8.86	1.77	7.07	0.35	1.26
KA 72	8.58	10.47	9.84	1.77	7.07	0.35	1.26
KA 72	9.57	11.46	10.83	1.77	7.07	0.35	1.26
KA 72	10.55	12.44	11.81	1.77	7.07	0.35	1.26
KA 72	11.54	13.43	12.80	1.77	7.07	0.35	1.26
KA 72	12.52	14.41	13.78	1.77	7.07	0.35	1.26
KA 72	13.50	15.39	14.76	1.77	7.07	0.35	1.26
KA 72	14.49	16.38	15.75	1.77	7.07	0.35	1.26
KA 72	16.46	18.35	17.72	1.77	7.07	0.35	1.26
KA 72	18.43	20.31	19.69	1.77	7.07	0.35	1.26
KA 72	20.39	22.28	21.65	1.77	7.07	0.35	1.26
KA 72	variable	A+1.89	A+1.26	1.77	7.07	0.35	1.26

Chain bracket angle

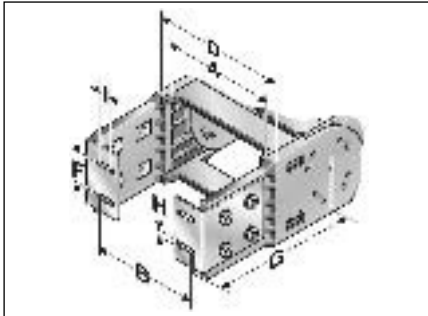

Front/Inside

Type	A inch	B inch	D inch	F inch	G inch	H Ø inch	I inch
KA 72	4.65	3.70	5.91	1.77	7.07	0.35	1.26
KA 72	5.63	4.69	6.89	1.77	7.07	0.35	1.26
KA 72	6.61	5.67	7.87	1.77	7.07	0.35	1.26
KA 72	7.60	6.65	8.86	1.77	7.07	0.35	1.26
KA 72	8.58	7.64	9.84	1.77	7.07	0.35	1.26
KA 72	9.57	8.62	10.83	1.77	7.07	0.35	1.26
KA 72	10.55	9.61	11.81	1.77	7.07	0.35	1.26
KA 72	11.54	10.59	12.80	1.77	7.07	0.35	1.26
KA 72	12.52	11.57	13.78	1.77	7.07	0.35	1.26
KA 72	13.50	12.56	14.76	1.77	7.07	0.35	1.26
KA 72	14.49	13.54	15.75	1.77	7.07	0.35	1.26
KA 72	16.46	15.51	17.72	1.77	7.07	0.35	1.26
KA 72	18.43	17.48	19.69	1.77	7.07	0.35	1.26
KA 72	20.39	19.45	21.65	1.77	7.07	0.35	1.26
KA 72	variable	A-0.94	A+1.26	1.77	7.07	0.35	1.26

Assembly instruction flexible chain bracket

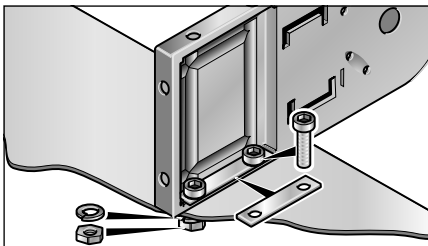

The flexible chain bracket is delivered with insert panels to prevent cold flow by the plastic.

Separator

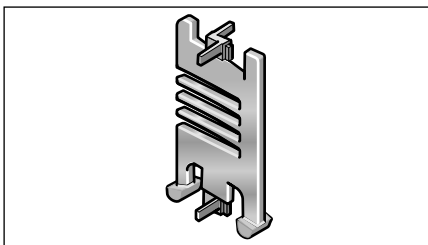

Separator

Type	Order no.	Designation	Lock grid spacing inch	Pack qty.
TR 72	072000009200	Separator	0.20	1

We recommend that separators be used if multiple round cables or conduits with differing diameters are to be installed. An offset configuration of the separators is advisable.

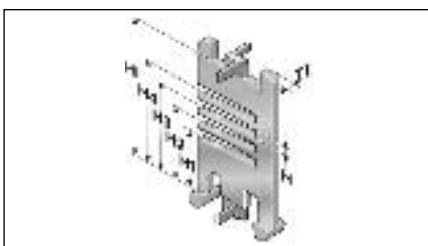

Separator

Type	TI inch	H inch	H1 inch	H2 inch	H3 inch	H4 inch	HI inch
TR 72	0.14	0.22	1.00	1.42	1.83	2.24	2.83



MP 72 - Accessories

H-shaped shelf unit

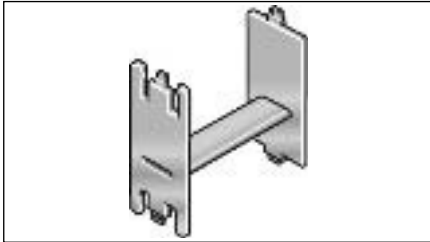

H-shaped shelf unit

Type	Order no.	Designation	Lock grid spacing inch	Pack qty.
RE 75/24	100000752418	RE 75/24 H-shaped shelf unit	0.20	1
RE 75/36	100000753618	RE 75/36 H-shaped shelf unit	0.20	1

Insert to obtain additional levels in pre-defined distances.

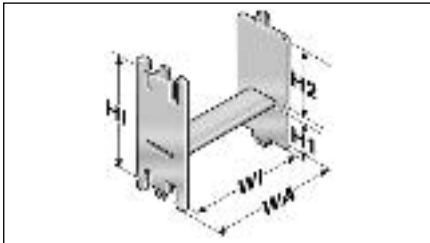

H-shaped shelf unit

Type	WA inch	WI inch	H1 inch	H2 inch	HI inch
RE 75/24	2.95	2.66	1.69	0.94	2.83
RE 75/36	2.95	2.66	1.32	1.32	2.83

Shelving system

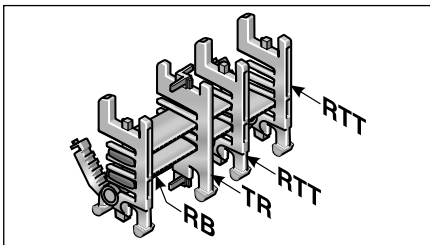

Shelving system

Type	Order no.	Designation	Width inch	Lock grid spacing inch	Pack qty.
RB 056-7	100000005600	RB 056-7 Shelf	2.20	0.20	1
RB 066-7	100000006600	RB 066-7 Shelf	2.60	0.20	1
RB 081-7	100000008100	RB 081-7 Shelf	3.19	0.20	1
RB 106-7	100000010600	RB 106-7 Shelf	4.17	0.20	1
RB 116-7	100000011600	RB 116-7 Shelf	4.57	0.20	1
RB 166-7	100000016600	RB 166-7 Shelf	6.54	0.20	1
RB 216-7	100000021600	RB 216-7 Shelf	8.50	0.20	1
RTT 72	100090722000	RTT 72 Shelf support, divisible		0.20	1

In connection with at least two shelf supports (RTT) the shelf becomes a shelving system. The additional levels prevent cables from criss-crossing and therefore destroying each other, while also avoiding excessive friction. The shelving system may be pre-assembled on request.

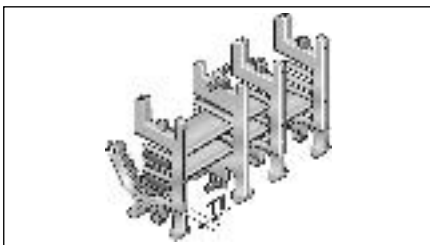

Shelving system

Type	TI inch
RTT 72	0.31

Crossbar strain relief plate RS-ZL

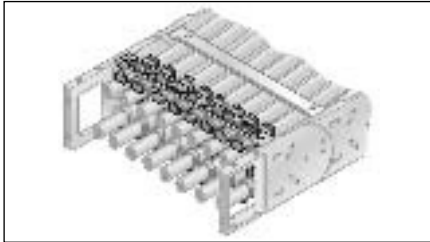

Crossbar strain relief plate RS-ZL

Type	Order no.	For internal width inch	Pack qty.
RS-ZL 118-7	072011800010	4.65	1
RS-ZL 143-7	072014300010	5.63	1
RS-ZL 168-7	072016800010	6.61	1
RS-ZL 193-7	072019300010	7.60	1
RS-ZL 218-7	072021800010	8.58	1
RS-ZL 243-7	072024300010	9.57	1

Fixed integrated frame bridge strain relief plates in the chain brackets. Accommodated to all widths of the frame ridges, up to 9.57 in (243 mm) in size. May be assembled on the inside and outside flexure curves at both chain endings.

Strain relief type BAK

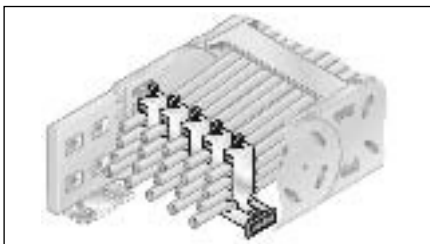

Strain relief with hooped clamp

Type	Order no.	Designation	Ø inch	Number of seats	Pack qty.
C-rail	81661610	C-profile rail			1
BA 12	81661036	BA 12 Hooped clamp	0.35–0.47	1	1
BAK 14	81661002	BAK 14 Hooped clamp	0.24–0.55	1	1
BAK 18	81661004	BAK 18 Hooped clamp	0.55–0.71	1	1
BAK 22	81661006	BAK 22 Hooped clamp	0.71–0.87	1	1
BAK 26	81661008	BAK 26 Hooped clamp	0.87–1.02	1	1
BAK 30	81661010	BAK 30 Hooped clamp	1.02–1.18	1	1
BAK 34	81661000	BAK 34 Hooped clamp	1.18–1.34	1	1
BAK 38	81661044	BAK 38 Hooped clamp	1.34–1.50	1	1
BAK 42	81661032	BAK 42 Hooped clamp	1.50–1.65	1	1
BAK 46	81661050	BAK 46 Hooped clamp	1.65–1.81	1	1
BA 12/2	81661038	BA 12/2 Hooped clamp	0.35–0.47	2	1
BAK 14/2	81661012	BAK 14/2 Hooped clamp	0.39–0.55	2	1
BAK 18/2	81661014	BAK 18/2 Hooped clamp	0.55–0.71	2	1
BAK 22/2	81661016	BAK 22/2 Hooped clamp	0.71–0.87	2	1
BAK 26/2	81661018	BAK 26/2 Hooped clamp	0.87–1.02	2	1
BAK 30/2	81661048	BAK 30/2 Hooped clamp	1.02–1.18	2	1
BAK 34/2	81661044	BAK 34/2 Hooped clamp	1.18–1.34	2	1
BAK 38/2	81661046	BAK 38/2 Hooped clamp	1.34–1.50	2	1
BAK 42/2	81661034	BAK 42/2 Hooped clamp	1.50–1.65	2	1
BAK 12/3	81661020	BAK 12/3 Hooped clamp	0.35–0.47	3	1
BAK 14/3	81661022	BAK 14/3 Hooped clamp	0.47–0.55	3	1
BAK 16/3	81661024	BAK 16/3 Hooped clamp	0.55–0.63	3	1
BAK 18/3	81661026	BAK 18/3 Hooped clamp	0.63–0.71	3	1
BAK 20/3	81661028	BAK 20/3 Hooped clamp	0.71–0.79	3	1
BAK 22/3	81661030	BAK 22/3 Hooped clamp	0.79–0.87	3	1

Fixed integrated strain relief in the chain connections. Available in all widths (also individual widths for aluminum frame ridges). May be assembled on the inside and outside flexure curves at both chain endings. Chain content is secured through hooped clamps that are available in different sizes. Material: Galvanized steel.

When ordering please indicate the type of chain and internal width.



Crossbar connector

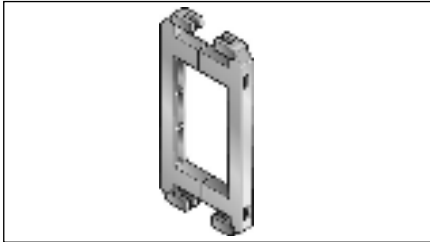

Crossbar connector

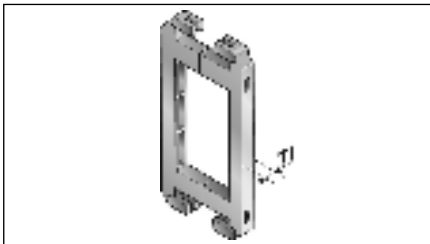

Type	Order no.	Designation	Pack qty.
RSV 72	072000009600	RSV 72 Crossbar connector	1
RSV 72 Alu	072000009800	RSV 72 Crossbar connector for aluminum crossbridges	1

For frame bridges wider than 9.69 in (246 mm), we recommend the use of crossbar connectors. These prevent deformation to the frame bridge under large amounts of additional weight of the chain assembly.

Type	Dimension TI inch
RSV 72	0.31
RSV 72 Alu	0.31

Reverse radius

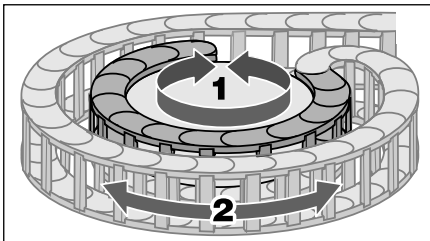

Rotating movement

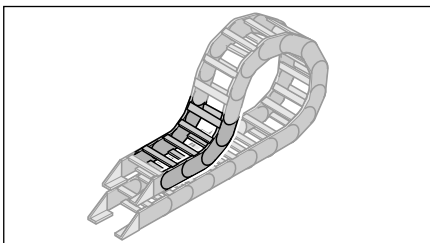

lowered chain bracket

Type	Order no.	Radius inch	Reverse radius inch	Pack qty.
SR 72 (RÜ300/R300) left	72000030060	11.81	11.81	1
SR 72 (RÜ300/R300) right	72000030062	11.81	11.81	1

Side links with radius forward (R) and radius backward (Rü) allow for movement in two directions. This is intended for rotating movements and lowered chain brackets.
Note: This type of chain has different chain links for the left or right side!

Assembly

Disassembly

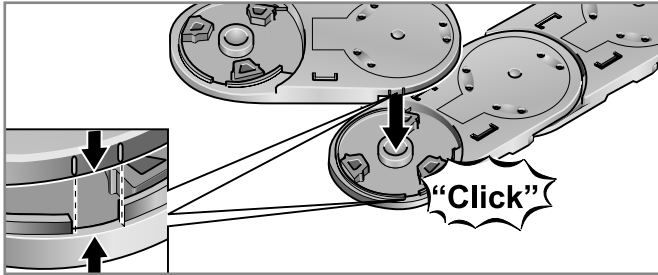

Step 1

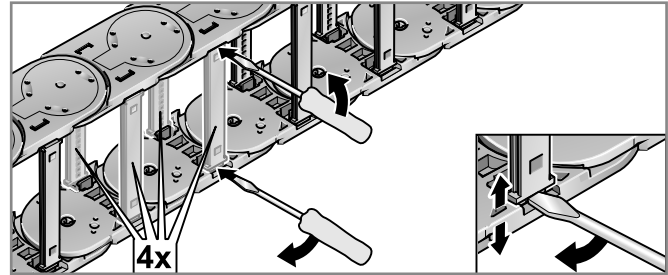

Step 1

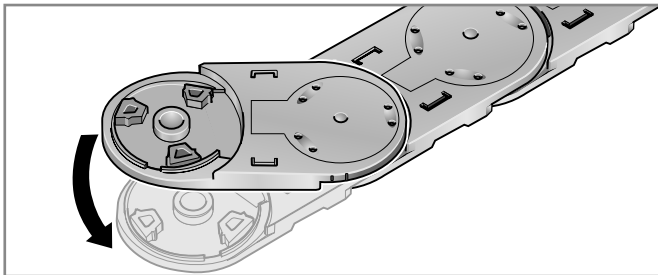

Step 2

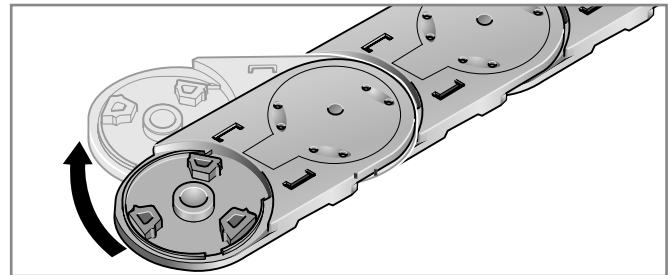

Step 2

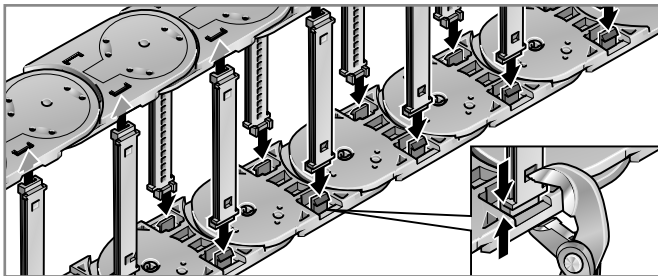

Step 3

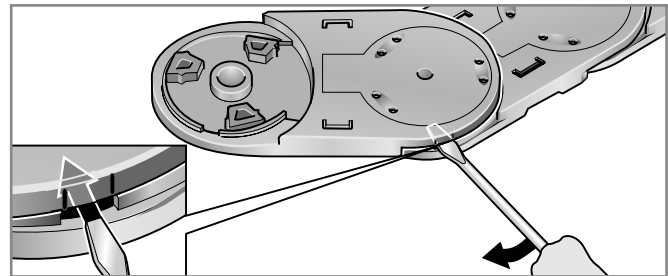

Step 3



Cable drag chain systems

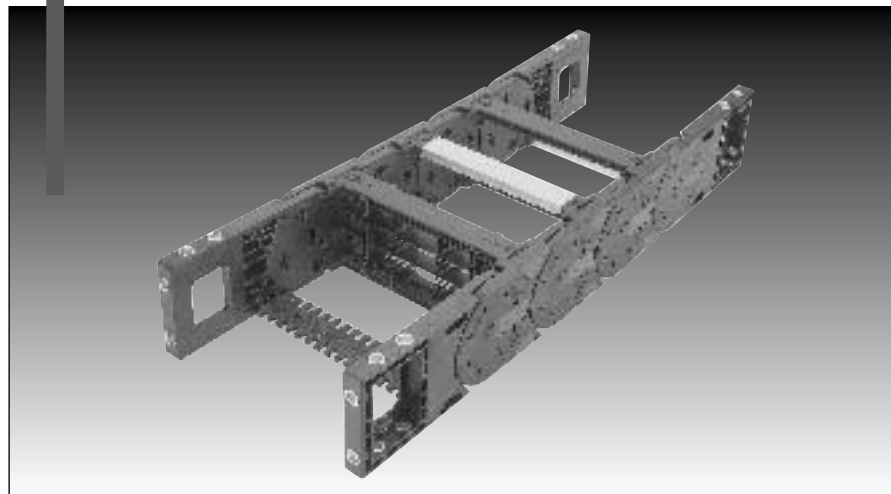

HeavyLine

MP 82.2



MP 82.2 - PowerLine 2nd generation

Order variants

Style (order code)

Configuration (order code) * = standard

Radius (order code) The radii can be combined with any internal width

in inch

Internal width (order code)

in inch

Outside width

in inch

MP 82.2 118	6.42	4.65	118						
MP 82.2 143	7.40	5.63	143						
MP 82.2 168	8.39	6.61	168						
MP 82.2 193	9.37	7.60	193						
MP 82.2 218	10.35	8.58	218						
MP 82.2 243	11.34	9.57	243						
MP 82.2 268	12.32	10.55	268						
MP 82.2 293	13.31	11.54	293						
MP 82.2 318	14.29	12.52	318	5.91	150			0	
MP 82.2 343	15.28	13.50	343	7.87	200			1	
MP 82.2 368	16.26	14.49	368	9.84	250			2*	
MP 82.2 418	18.23	16.46	418	11.81	300			3*	
MP 82.2 468	20.20	18.43	468	13.78	350			4	
MP 82.2 518	22.17	20.39	518	15.75	400			5	0
MP 82.2 xxx	inside + 1.77	>4.65 -23.62	Alu	19.69	500			6	5
				25.59	650			7	7
								9	9

Order-Number:

Configuration:

- 0 PA crossbar every link; w/bias
- 1 PA crossbar every link; w/o bias
- 2* PA crossbar EOL; w/bias
- 3* PA crossbar EOL; w/o bias
- 4 AL crossbar every link; w/bias
- 5 AL crossbar every link; w/o bias
- 6 AL crossbar EOL; w/bias
- 7 AL crossbar EOL; w/o bias
- 9 Custom version

Style:

- 0 Standard (PA/black)
- 5 Polypropylene (PP/blue)
- 7 ESD (PA/light gray)
- 9 Custom version

Sample order:

0822 118 150 0000







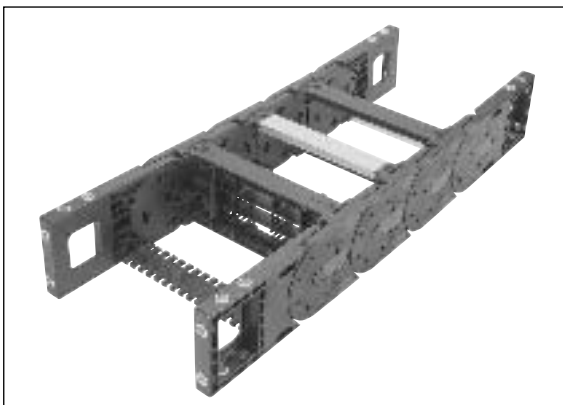

Internal width = 4.65 in (118 mm)
 Radius = 5.91 in (150 mm)
 Configuration = 0
 Style = 0

Ideal operating conditions:

- Extreme accelerations
- Extreme speeds
- Very high additional loads
- Both sides must be opened
- Aluminum frame bridge in variable lengths
- Flexible internal separation
- Version with/without bias

Features



-  Chain bracket, can be fastened on three sides
-  Crossbar strain relief can be integrated into chain bracket
-  Crossbar/cover can be removed from inside and outside flexure curve
-  Side links with CLICK lock for easy opening
-  Radii with or without bias (RV/RK)
-  ESD cable drag chains for use in areas at risk of explosion
-  Reverse radius combinations
-  Aluminum frame bridges with integrated lock grid in variable lengths
-  Foldable shelf system for reliable cable guidance

Technical data

Chain link dimensions (inch) (mm)

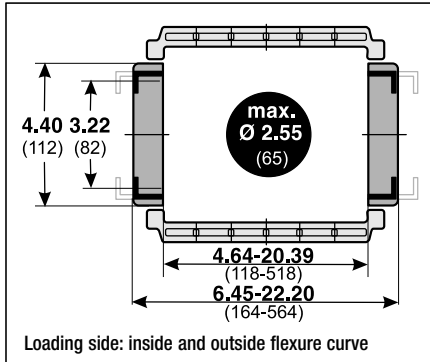

Material characteristics standard (PA/black)

Operating temperature: -22 to 248° F
 Gliding friction factor: 0.30
 Static friction factor: 0.45
 Fire classification: Based on UL94 HB

Other material properties on request

Technical specifications

Travel distance, gliding, L_g : 492.13 ft
 Travel distance, self-supporting, L_s : see diagram
 Travel distance, vertical, hanging, L_{vh} : 393.70 ft
 Travel distance, vertical, upright, L_{vu} : 19.69 ft
 Rotated 90°, self-supporting, L_{90r} : 9.84 ft
 Speed, gliding, V_g : 16.40 ft/s
 Speed, self-supporting, V_s : 65.62 ft/s
 Acceleration, gliding, a_g : 82.02 ft/s²
 Acceleration, self-supporting, a_s : 131.23 ft/s²

Self-supporting length

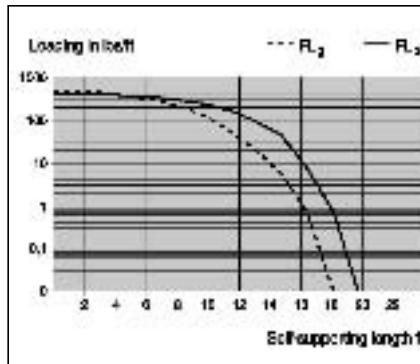
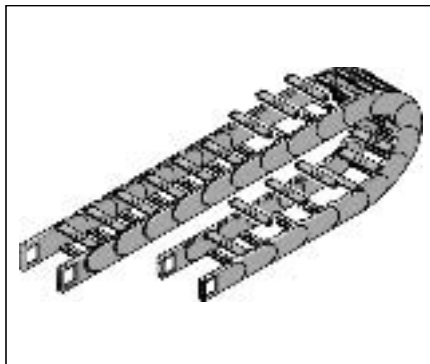

FL₁:
 Ideal installation situation for high stresses at the limit of the max. travel parameters. In this range the chain upper run is still biased, straight or has a max. sag of 0.39 – 1.97 in (10 – 50 mm) depending on the type of chain.

FL₂:
 Satisfactory installation position for many applications working in the lower to middle range of the max. travel parameters. Depending on the chain type, the sag of the chain upper run is >0.39 – 1.97 in (>10 – 50 mm) but certainly less than the max. sag.

If the sag is greater than FL₂, the arrangement is unsuitable and should be avoided. Please choose a more stable Murrplastik cable drag chain.

Determining the chain length

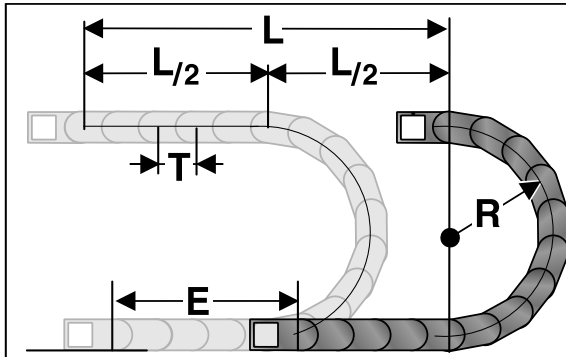

L = Travel distance
 R = Radius
 T = Pitch
 E = Distance between entry point and middle of travel distance

Determining the chain length

$$\text{Length} = \frac{L}{2} + \pi \times R + E$$

≈ 1 ft(m) chain = 3(9) links each 4.65 in (118 mm)

The fixed point of the cable drag chain should be connected in the middle of the travel distance. This arrangement gives the shortest connection between the fixed point and the moving point and thus the most efficient chain length.

Installation dimensions (in inch)

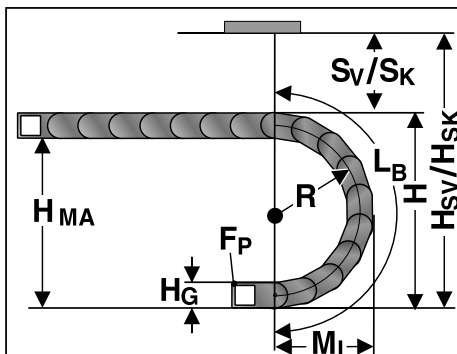

Radius R	5.91	7.87	9.84	11.81	13.78	15.75	19.69	25.59
Outside height of chain link (H_o)	4.41	4.41	4.41	4.41	4.41	4.41	4.41	4.41
Height of bend (H)	16.61	20.55	24.49	28.43	32.36	36.30	44.17	1422
Height of moving end connection (H_{Ma})	12.20	16.14	20.08	24.02	27.95	31.89	39.76	51.57
Safety margin with bias (S_v)	1.97	1.97	1.97	1.97	1.97	1.97	1.97	1.97
Installation height with bias (H_{sv})	18.58	22.52	26.46	30.39	34.33	38.27	46.14	57.95
Safety margin without bias (S_k)	1.18	1.18	1.18	1.18	1.18	1.18	1.18	1.18
Installation height without bias (H_{sk})	17.80	21.73	25.67	29.61	33.54	37.48	45.35	57.17
Arc projection (M_l)	12.95	14.92	16.89	18.86	20.83	22.80	26.73	32.64
Bend length (L_b)	30.75	36.93	43.11	49.29	55.47	61.65	74.02	92.56



MP 82.2 - PowerLine 2nd generation

Chain bracket

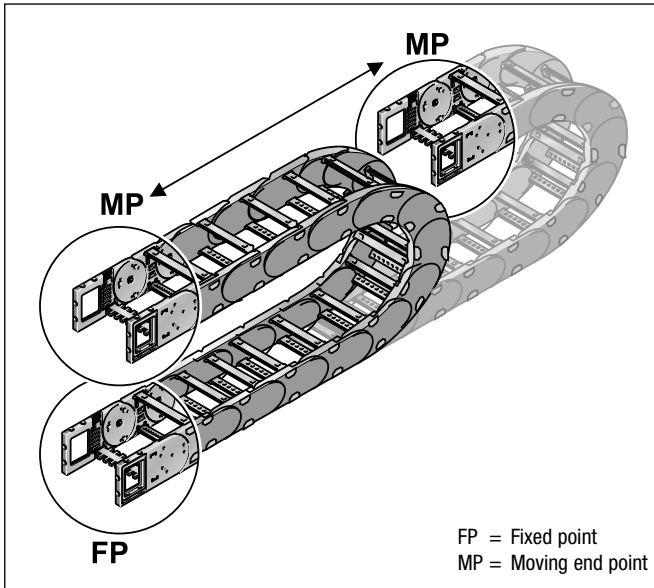

Flexible chain bracket

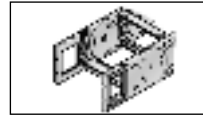

Flexible

Flexible chain bracket

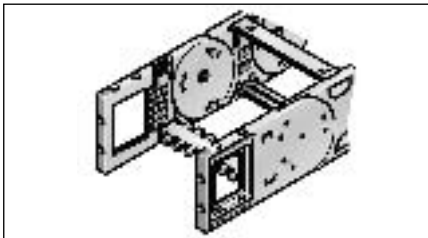

KA 82-F...

Type	Order no.	Version	Pack qty.
KA 82-FB Female end	0820000056	with bushing	1
KA 82-FB Male end	0820000057	with bushing	1
KA 82-FG Female end	0820000058	with thread	1
KA 82-FG Male end	0820000059	with thread	1

This chain bracket offers universal connection options (top, bottom and front) and is attached to the ends of the chain like a side link. This allows the chain to move right up to the bracket. Each chain requires one male and one female bracket. Use M10 screws for connecting. Extrusion-coated metal bushes with either a through-hole (-FB) or a threaded hole (-FG) ensure the permanent, high-strength transmission of even extreme forces onto the cable drag chain.

Flexible chain bracket

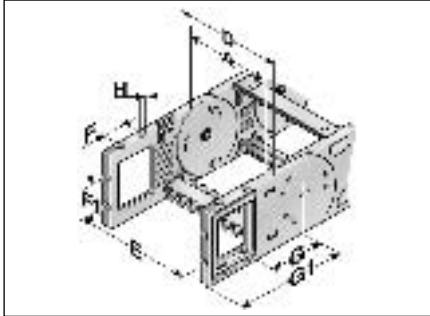

Flexible with through-hole

Type	A inch	D inch	E inch	F inch	F1 inch	G inch	G1 inch	H Ø inch
KA 82-FB	4.65	6.42	5.55	1.38	2.6	4.61	7.17	0.43
KA 82-FB	5.63	7.40	6.54	1.38	2.6	4.61	7.17	0.43
KA 82-FB	6.61	8.39	7.52	1.38	2.6	4.61	7.17	0.43
KA 82-FB	7.60	9.37	8.50	1.38	2.6	4.61	7.17	0.43
KA 82-FB	8.58	10.35	9.49	1.38	2.6	4.61	7.17	0.43
KA 82-FB	9.57	11.34	10.47	1.38	2.6	4.61	7.17	0.43
KA 82-FB	10.55	12.32	11.46	1.38	2.6	4.61	7.17	0.43
KA 82-FB	11.54	13.31	12.44	1.38	2.6	4.61	7.17	0.43
KA 82-FB	12.52	14.92	13.43	1.38	2.6	4.61	7.17	0.43
KA 82-FB	13.50	15.28	14.41	1.38	2.6	4.61	7.17	0.43
KA 82-FB	14.49	16.26	15.39	1.38	2.6	4.61	7.17	0.43
KA 82-FB	16.46	18.23	17.36	1.38	2.6	4.61	7.17	0.43
KA 82-FB	18.43	20.20	19.33	1.38	2.6	4.61	7.17	0.43
KA 82-FB	20.39	22.17	21.30	1.38	2.6	4.61	7.17	0.43
KA 82-FB	variable	A+1.77	A+0.91	1.38	2.6	4.61	7.17	0.43

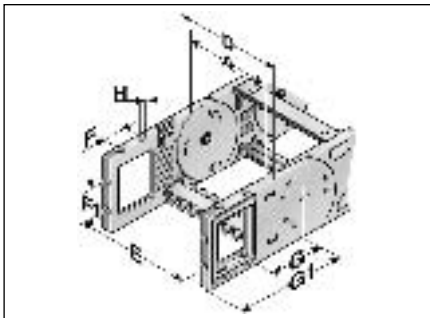

Flexible with threaded bushing

Type	A inch	D inch	E inch	F inch	F1 inch	G inch	G1 inch	H
KA 82-FG	4.65	6.42	5.55	1.38	2.6	4.61	7.17	M10
KA 82-FG	5.63	7.40	6.54	1.38	2.6	4.61	7.17	M10
KA 82-FG	6.61	8.39	7.52	1.38	2.6	4.61	7.17	M10
KA 82-FG	7.60	9.37	8.50	1.38	2.6	4.61	7.17	M10
KA 82-FG	8.58	10.35	9.49	1.38	2.6	4.61	7.17	M10
KA 82-FG	9.57	11.34	10.47	1.38	2.6	4.61	7.17	M10
KA 82-FG	10.55	12.32	11.46	1.38	2.6	4.61	7.17	M10
KA 82-FG	11.54	13.31	12.44	1.38	2.6	4.61	7.17	M10
KA 82-FG	12.52	14.92	13.43	1.38	2.6	4.61	7.17	M10
KA 82-FG	13.50	15.28	14.41	1.38	2.6	4.61	7.17	M10
KA 82-FG	14.49	16.26	15.39	1.38	2.6	4.61	7.17	M10
KA 82-FG	16.46	18.23	17.36	1.38	2.6	4.61	7.17	M10
KA 82-FG	18.43	20.20	19.33	1.38	2.6	4.61	7.17	M10
KA 82-FG	20.39	22.17	21.30	1.38	2.6	4.61	7.17	M10
KA 82-FG	variable	A+1.77	A+0.91	1.38	2.6	4.61	7.17	M10



Assembly instruction flexible chain bracket

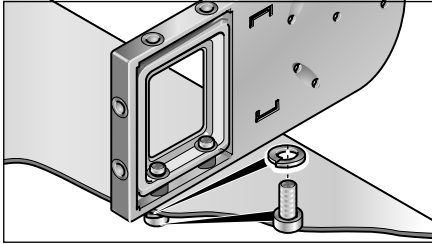

Chain bracket with threaded bushing

Brass bushings guarantee long-lasting fastening without cold flow in the plastic.

Version KA-FB:

Integrated through-hole fastened down using screw and nut.

Version KA-FG:

Built-in threads allow for quick and easy on-site mounting, since a screw, including a retaining washer where necessary, is sufficient.

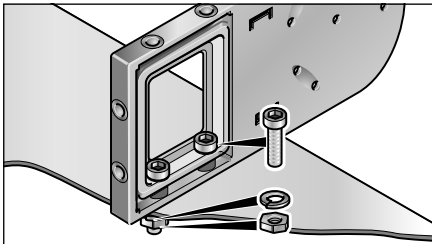

Chain bracket with bushing

Separator

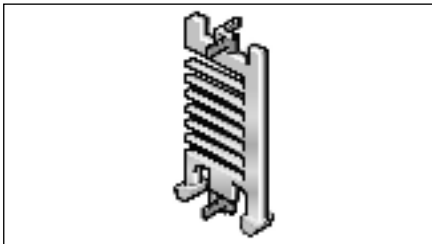

Separator

Type	Order no.	Designation	Lock grid spacing inch	Pack qty.
TR 82	082000009200	Separator	0.20	1

We recommend that separators be used if multiple round cables or conduits with differing diameters are to be installed. An offset configuration of the separators is advisable.

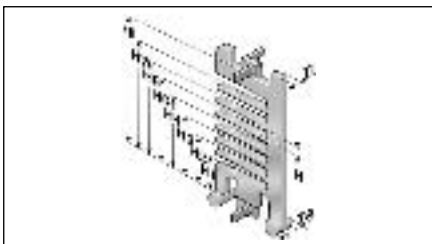

Separator

Type	T1 inch	H inch	H1 inch	H2 inch	H3 inch	H4 inch	H5 inch	H6 inch	H7 inch	H1 inch
TR 82	0.14	0.21	0.48	0.81	1.13	1.46	1.79	2.11	2.44	3.13

Shelving system

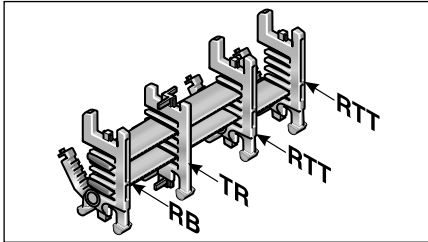

Shelving system

Type	Order no.	Designation	Width inch	Lock grid spacing inch	Pack qty.
RB 056-7	100000005600	RB 056-7 Shelf	2.20	0.20	1
RB 066-7	100000006600	RB 066-7 Shelf	2.60	0.20	1
RB 081-7	100000008100	RB 081-7 Shelf	3.19	0.20	1
RB 106-7	100000010600	RB 106-7 Shelf	4.17	0.20	1
RB 116-7	100000011600	RB 116-7 Shelf	4.57	0.20	1
RB 166-7	100000016600	RB 166-7 Shelf	6.54	0.20	1
RB 8.50-7	100002001600	RB 8.50-7 Shelf	8.50	0.20	1
RTT 82	100090822000	RTT 82 Shelf support, divisible		0.20	1

In connection with at least two shelf supports (RTT) the shelf becomes a shelving system. The additional levels prevent cables from criss-crossing and therefore destroying each other, while also avoiding excessive friction. The shelving system may be pre-assembled on request.

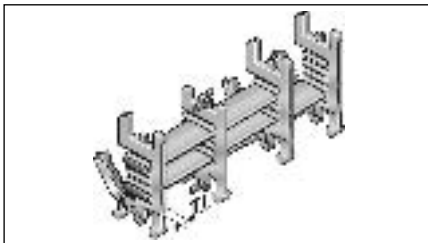

Shelving system

Type	TI inch
RTT 82	0.31

Crossbar connector

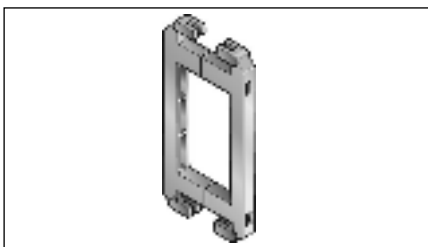

Crossbar connector

Type	Order no.	Designation	Pack qty.
RSV 82	082000009600	RSV 82 Crossbar connector	1
RSV 82 A	082000009800	RSV 82 Alu crossbar connector for aluminum crossbridges	1

For frame bridges wider than 9.69 in (246 mm), we recommend the use of crossbar connectors. These prevent deformation of the frame bridge under large amounts of additional weight of the chain assembly.

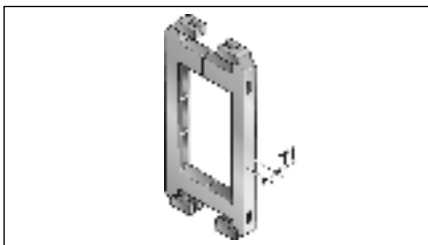

Type	TI inch
RSV 82	0.31



Crossbar strain relief plate RS-ZL

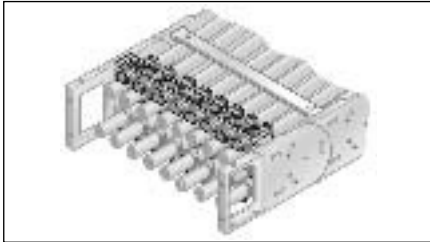

Crossbar strain relief plate RS-ZL

Type	Order no.	For internal width inch	Pack qty.
RS-ZL 118-7	072011800010	4.65	1
RS-ZL 143-7	072014300010	5.63	1
RS-ZL 168-7	072016800010	6.61	1
RS-ZL 193-7	072019300010	7.60	1
RS-ZL 218-7	072021800010	8.58	1
RS-ZL 243-7	072024300010	9.57	1

Fixed integrated frame bridge strain relief plates in the chain brackets. Accommodated to all widths of the frame ridges, up to 9.57 in (243 mm) in size. May be assembled on the inside and outside flexure curves at both chain endings.

Strain relief type BAK

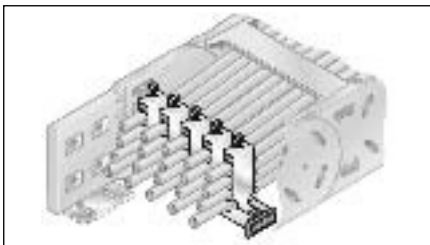

Strain relief with hooped clamp

Type	Order no.	Designation	Ø inch	Number of seats	Pack qty.
C-rail	81661610	C-profile rail			1
BA 12	81661036	BA 12 Hooped clamp	0.35–0.47	1	1
BAK 14	81661002	BAK 14 Hooped clamp	0.24–0.55	1	1
BAK 18	81661004	BAK 18 Hooped clamp	0.55–0.71	1	1
BAK 22	81661006	BAK 22 Hooped clamp	0.71–0.87	1	1
BAK 26	81661008	BAK 26 Hooped clamp	0.87–1.02	1	1
BAK 30	81661010	BAK 30 Hooped clamp	1.02–1.18	1	1
BAK 34	81661000	BAK 34 Hooped clamp	1.18–1.34	1	1
BAK 38	81661044	BAK 38 Hooped clamp	1.34–1.50	1	1
BAK 42	81661032	BAK 42 Hooped clamp	1.50–1.65	1	1
BAK 46	81661050	BAK 46 Hooped clamp	1.65–1.81	1	1
BA 12/2	81661038	BA 12/2 Hooped clamp	0.35–0.47	2	1
BAK 14/2	81661012	BAK 14/2 Hooped clamp	0.39–0.55	2	1
BAK 18/2	81661014	BAK 18/2 Hooped clamp	0.55–0.71	2	1
BAK 22/2	81661016	BAK 22/2 Hooped clamp	0.71–0.87	2	1
BAK 26/2	81661018	BAK 26/2 Hooped clamp	0.87–1.02	2	1
BAK 30/2	81661048	BAK 30/2 Hooped clamp	1.02–1.18	2	1
BAK 34/2	81661044	BAK 34/2 Hooped clamp	1.18–1.34	2	1
BAK 38/2	81661046	BAK 38/2 Hooped clamp	1.34–1.50	2	1
BAK 42/2	81661034	BAK 42/2 Hooped clamp	1.50–1.65	2	1
BAK 12/3	81661020	BAK 12/3 Hooped clamp	0.35–0.47	3	1
BAK 14/3	81661022	BAK 14/3 Hooped clamp	0.47–0.55	3	1
BAK 16/3	81661024	BAK 16/3 Hooped clamp	0.55–0.63	3	1
BAK 18/3	81661026	BAK 18/3 Hooped clamp	0.63–0.71	3	1
BAK 20/3	81661028	BAK 20/3 Hooped clamp	0.71–0.79	3	1
BAK 22/3	81661030	BAK 22/3 Hooped clamp	0.79–0.87	3	1

Fixed integrated strain relief in the chain connections. Available in all widths (also individual widths for aluminum frame ridges). May be assembled on the inside and outside flexure curves at both chain endings. Chain content is secured through hooped clamps that are available in different sizes. Material: Galvanized steel.

When ordering please indicate the type of chain and internal width.

Reverse radius

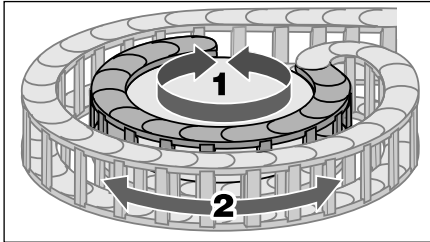

Rotating movement

Type	Order no.	Radius inch	Reverse radius inch	Pack qty.
SR 82.2 (RÜ300/R300) left	82200030060	11.81	11.81	1
SR 82.2 (RÜ300/R300) right	82200030062	11.81	11.81	1

Side links with radius forward (R) and radius backward (Rü) allow for movement in two directions. This is intended for rotating movements and lowered chain brackets.

Note: This type of chain has different chain links for the left or right side!

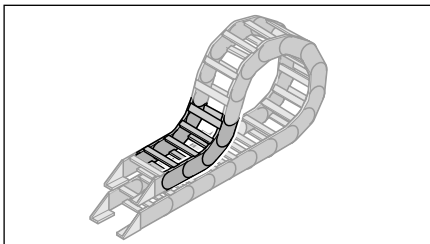

lowered chain bracket



MP 82.2 - Accessories

Assembly Disassembly

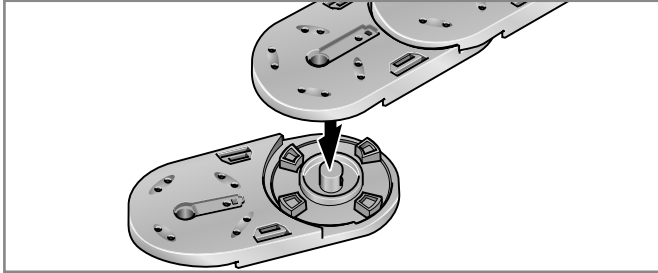

Step 1

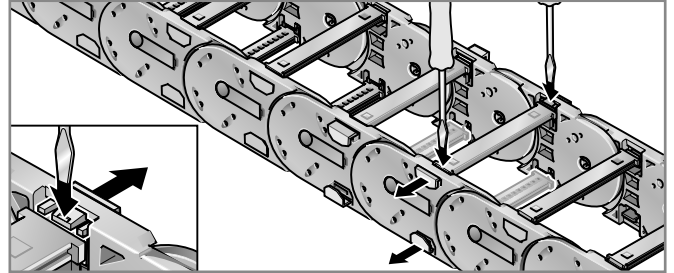

Step 1

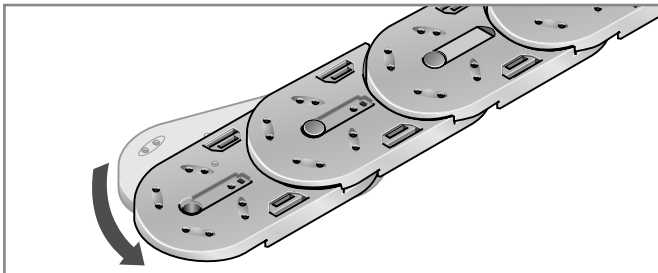

Step 2

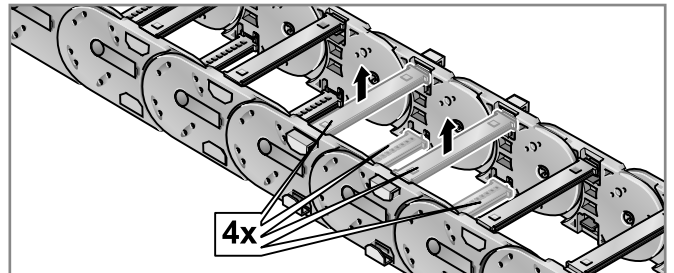

Step 2

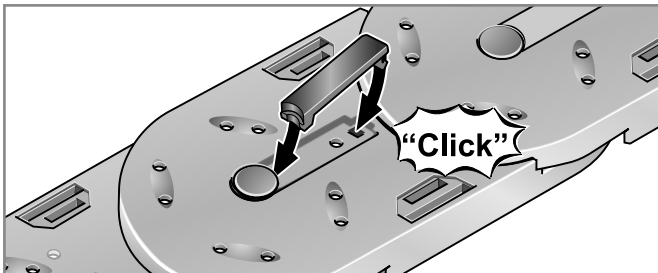

Step 3

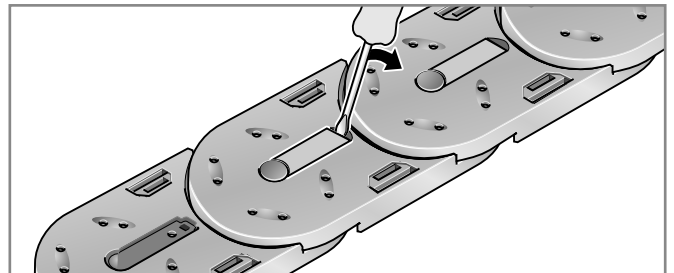

Step 3

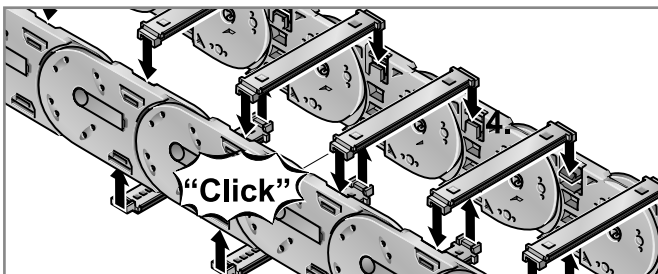

Step 4

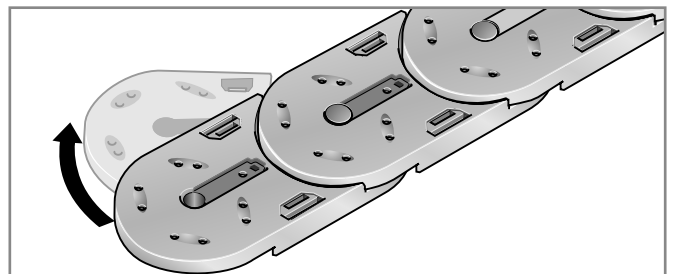

Step 4

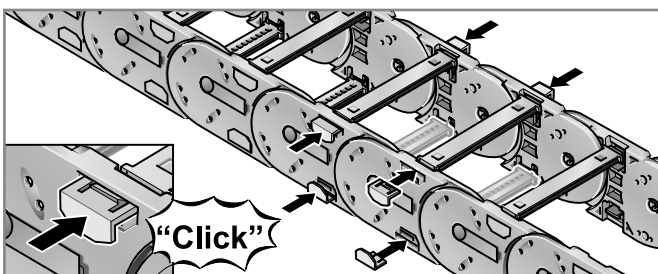

Step 5

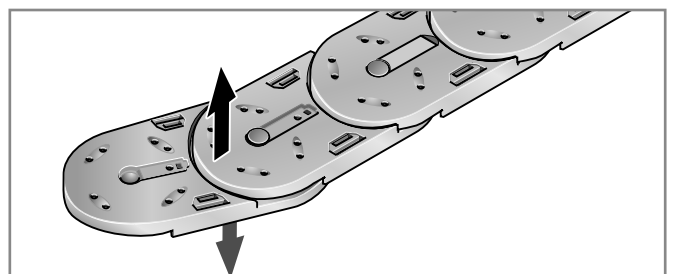

Step 5

Cable drag chain systems

HeavyLine

MP 102.2

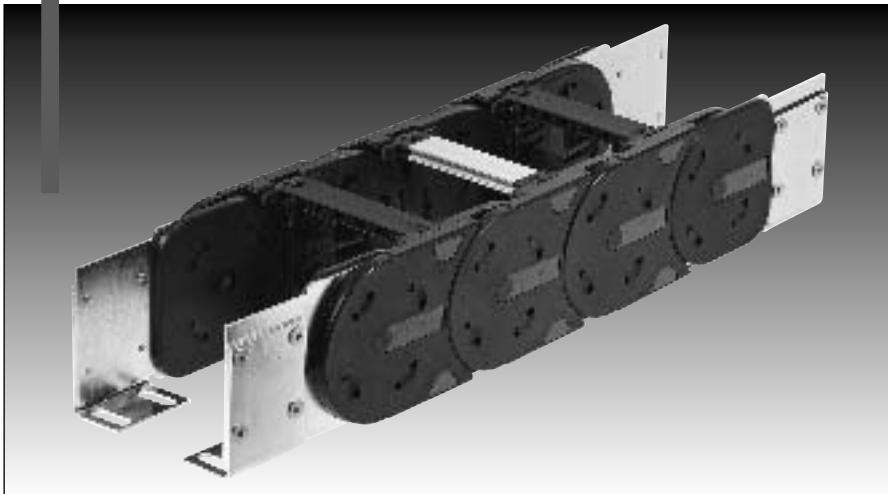



MP 102.2 - HeavyLine 2nd generation

Order variants

Style (order code)

Configuration (order code) * = standard

Radius (order code) The radii can be combined with any internal width

in inch

Internal width (order code)

in inch

Outside width (order code)

in inch

MP102.2 118	6.46	4.65	118			
MP102.2 143	7.44	5.63	143			
MP102.2 168	8.43	6.61	168			
MP102.2 192	9.41	7.60	193			
MP102.2 218	10.39	8.58	218			
MP102.2 243	11.38	9.57	243			
MP102.2 268	12.36	10.55	268			
MP102.2 293	13.35	11.54	293			
MP102.2 318	14.33	12.52	318			
MP102.2 343	15.31	13.50	343			
MP102.2 368	16.30	14.49	368			
MP102.2 418	18.27	16.46	418			0
MP102.2 468	20.24	18.43	468	9.84	250	2*
MP102.2 518	22.20	20.39	518	11.81	300	4
MP102.2 xxx	inside + 1.81	>118	Alu	15.75	400	6
				19.69	500	9
						0
						9

Order-Number:

Configuration:

- 0 PA crossbar every link; w/bias
- 2* PA crossbar EOL; w/bias
- 4 AL crossbar every link; w/bias
- 6 AL crossbar EOL; w/bias
- 9 Custom version

Style:

- 0 Standard (PA/black)
- 9 Custom version

Sample order:

1022 118 250 0000

Internal width = 4.65 in (118 mm)
 Radius = 9.84 in (250 mm)
 Configuration = 0
 Style = 0

Ideal operating conditions:

- Extreme accelerations
- Extreme speeds
- Extreme self-supporting lengths
- Very high additional loads
- Both sides must be opened
- Aluminum frame bridge in variable lengths
- Flexible internal separation
- Rotated 90° unsupported
- Rotated 90° horizontal
- version with bias (RV) for greater self-supporting length
- Version with bias (RV) for gliding arrangement

Features

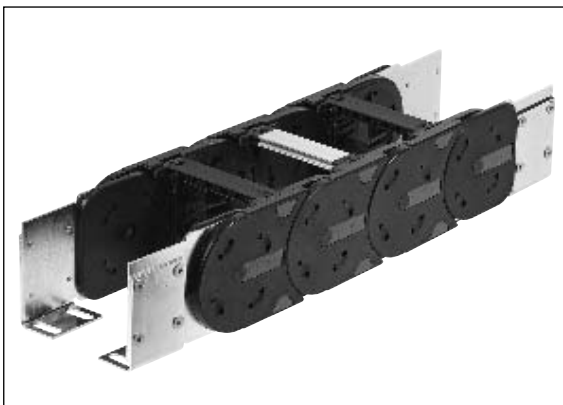

Chain bracket with variably positionable metal angle



Crossbar/cover can be removed from inside and outside flexure curve



Reverse radius combinations



Foldable shelf system for reliable cable guidance



Crossbar strain relief can be integrated into chain bracket



Radii with or without bias (RV/RK)



Aluminum frame bridges with integrated lock grid in variable lengths

Technical data

Chain link dimensions (inch) (mm)

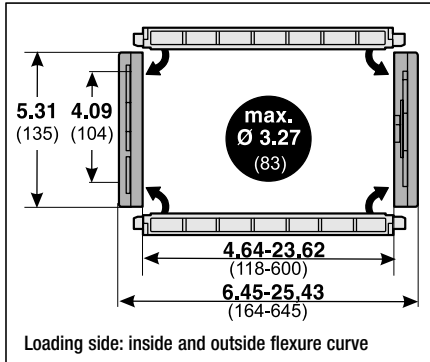

Material characteristics standard (PA/black)

Operating temperature: -22 to 248° F
 Gliding friction factor: 0.30
 Static friction factor: 0.45
 Fire classification: Based on UL94 HB

Other material properties on request

Technical specifications

Travel distance, gliding, L_g : 492.13 ft
 Travel distance, self-supporting, L_s : see diagram
 Travel distance, vertical, hanging, L_{vs} : 492.13 ft
 Travel distance, vertical, upright, L_{vs} : 26.25 ft
 Rotated 90° , self-supporting, L_{90r} : 26.25 ft
 Speed, gliding, V_g : 16.40 ft/s
 Speed, self-supporting, V_s : 65.62 ft/s
 Acceleration, gliding, a_g : 82.02 ft/s²
 Acceleration, self-supporting, a_s : 131.23 ft/s²

Self-supporting length

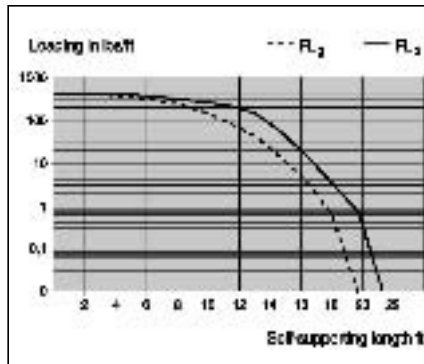
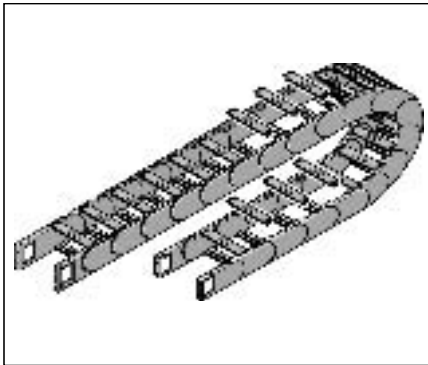

FL₁:
 Ideal installation situation for high stresses at the limit of the max. travel parameters. In this range the chain upper run is still biased, straight or has a max. sag of 0.39 – 1.97 in (10 – 50 mm) depending on the type of chain.

FL₂:
 Satisfactory installation position for many applications working in the lower to middle range of the max. travel parameters. Depending on the chain type, the sag of the chain upper run is $>0.39 - 1.97$ in ($>10 - 50$ mm) but certainly less than the max. sag.

If the sag is greater than FL₂, the arrangement is unsuitable and should be avoided. Please choose a more stable Murrplastik cable drag chain.

Determining the chain length

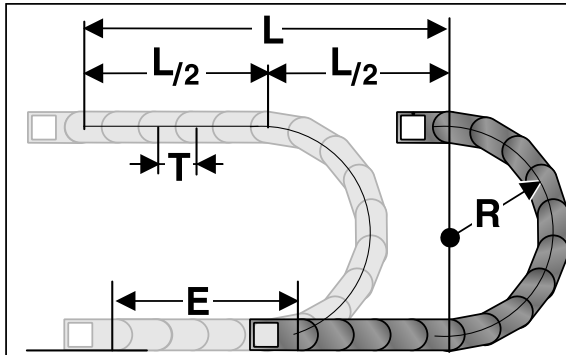

L = Travel distance
 R = Radius
 T = Pitch
 E = Distance between entry point and middle of travel distance

Determining the chain length

$$\text{Length} = \frac{L}{2} + \pi \times R + E$$

\approx 1 ft(m) chain = 2(7) links each 5.55 in (141 mm)

The fixed point of the cable drag chain should be connected in the middle of the travel distance. This arrangement gives the shortest connection between the fixed point and the moving point and thus the most efficient chain length.

Installation dimensions (in inch)

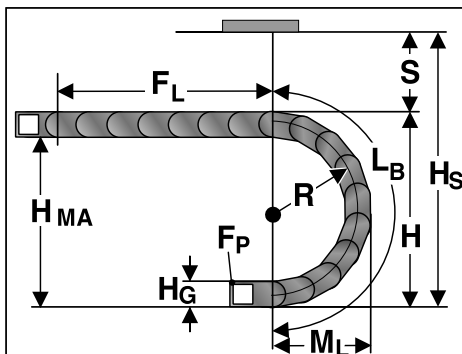

Radius R	9.84	11.81	15.75	19.69
Outside height of chain link (H_o)	5.31	5.31	5.31	5.31
Height of bend (H)	25.79	29.72	37.60	45.47
Height of moving end connection (H_{ma})	20.47	24.41	32.28	40.16
Safety margin (S)	1.97	1.97	1.97	1.97
Installation height (H_s)	27.76	31.69	39.57	47.44
Arc projection (M_L)	18.43	20.39	24.33	28.27
Bend length (L_b)	46.02	52.20	64.57	76.93



MP 102.2 - HeavyLine 2nd generation

Chain bracket

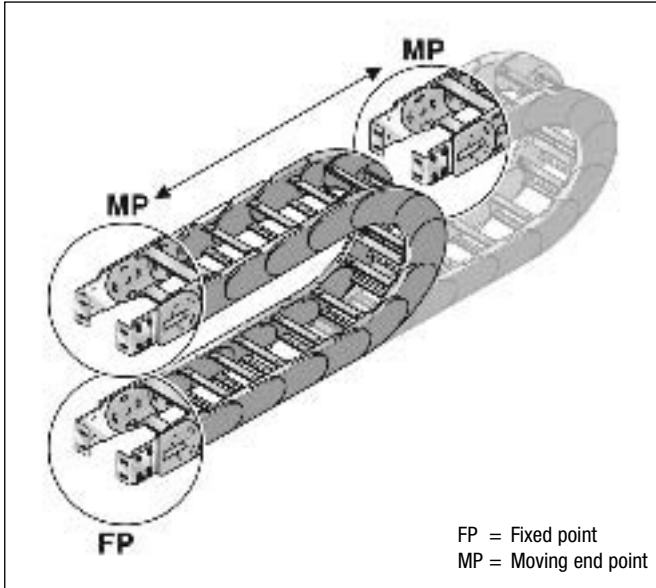

Chain bracket

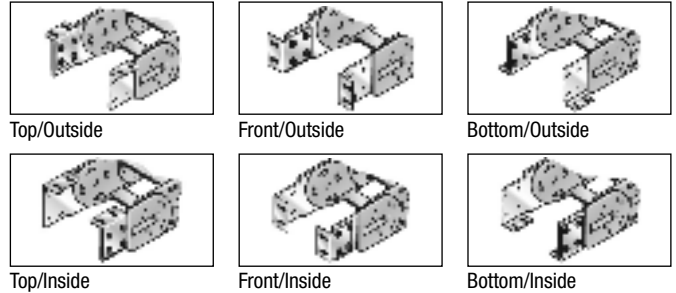

Chain bracket

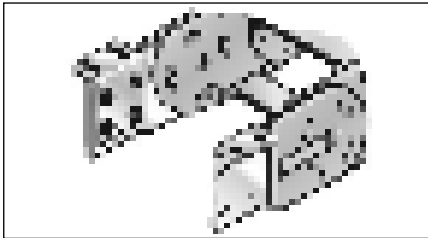

KA 102

Type	Order no.	Pack qty.
KA 102 Female end	1020000050	1
KA 102 Male end	1020000051	1

There are several options regarding the chain bracket. The fixed-point bracket (inside/bottom) and the moving end bracket (inside/top) are supplied as standard. However, any other combination can be supplied upon request. The chain bracket is fastened at the end like a side link. This enables the chain to move right up to the bracket. Each chain requires one male and one female bracket. Fasten the connections with M12 screws.

Chain bracket

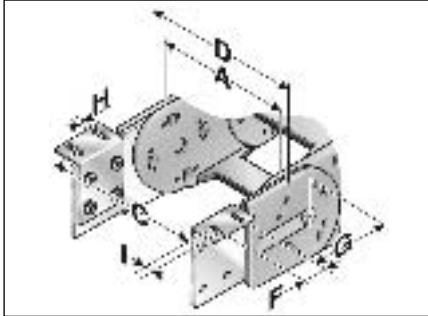

Bottom and top/outside

Type	A inch	C inch	D inch	F inch	G inch	H Ø inch	I inch
KA 102	4.65	6.14	6.46	1.97	3.74	0.51	0.98
KA 102	5.63	7.13	7.44	1.97	3.74	0.51	0.98
KA 102	6.61	8.11	8.43	1.97	3.74	0.51	0.98
KA 102	7.60	9.09	9.41	1.97	3.74	0.51	0.98
KA 102	8.58	10.08	10.39	1.97	3.74	0.51	0.98
KA 102	9.57	11.06	11.38	1.97	3.74	0.51	0.98
KA 102	10.55	12.05	12.36	1.97	3.74	0.51	0.98
KA 102	11.54	13.03	13.35	1.97	3.74	0.51	0.98
KA 102	12.52	14.02	14.33	1.97	3.74	0.51	0.98
KA 102	13.50	15.00	15.31	1.97	3.74	0.51	0.98
KA 102	14.49	15.98	16.30	1.97	3.74	0.51	0.98
KA 102	16.46	17.95	18.27	1.97	3.74	0.51	0.98
KA 102	18.43	19.92	19.25	1.97	3.74	0.51	0.98
KA 102	20.39	22.28	22.20	1.97	3.74	0.51	0.98
KA 102	variable	A+1.50	A+1.81	1.97	3.74	0.51	0.98

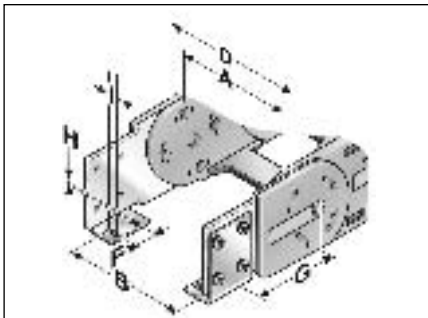

Bottom and top/inside

Type	A inch	B inch	D inch	F inch	G inch	H Ø inch	I inch
KA 102	4.65	4.72	6.46	1.97	3.74	0.51	0.98
KA 102	5.63	5.71	7.44	1.97	3.74	0.51	0.98
KA 102	6.61	6.69	8.43	1.97	3.74	0.51	0.98
KA 102	7.60	7.68	9.41	1.97	3.74	0.51	0.98
KA 102	8.58	8.58	10.39	1.97	3.74	0.51	0.98
KA 102	9.57	9.65	11.38	1.97	3.74	0.51	0.98
KA 102	10.55	10.63	12.36	1.97	3.74	0.51	0.98
KA 102	11.54	11.61	13.35	1.97	3.74	0.51	0.98
KA 102	12.52	12.60	14.33	1.97	3.74	0.51	0.98
KA 102	13.50	13.58	15.31	1.97	3.74	0.51	0.98
KA 102	14.49	14.75	16.30	1.97	3.74	0.51	0.98
KA 102	16.46	16.54	18.27	1.97	3.74	0.51	0.98
KA 102	18.43	18.50	19.25	1.97	3.74	0.51	0.98
KA 102	20.39	20.47	22.20	1.97	3.74	0.51	0.98
KA 102	variable	A+0.08	A+1.81	1.97	3.74	0.51	0.98



MP 102.2 - HeavyLine 2nd generation

Chain bracket

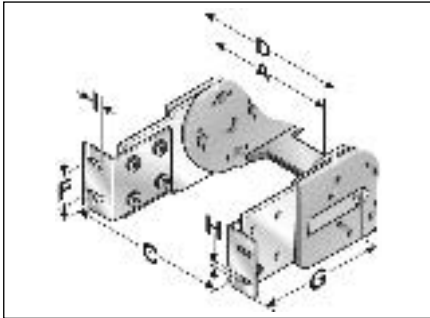

Front/Outside

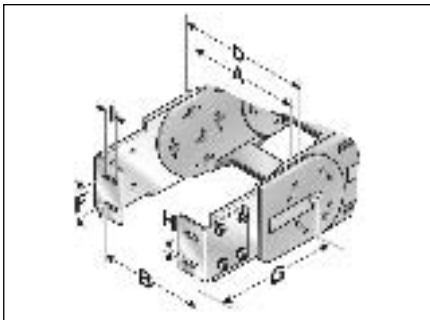

Front/Inside

Type	A inch	C inch	D inch	F inch	G inch	H Ø inch	I inch
KA 102	4.65	6.14	6.46	1.97	7.38	0.51	0.98
KA 102	5.63	7.13	7.44	1.97	7.38	0.51	0.98
KA 102	6.61	8.11	8.43	1.97	7.38	0.51	0.98
KA 102	7.60	9.09	9.41	1.97	7.38	0.51	0.98
KA 102	8.58	10.08	10.39	1.97	7.38	0.51	0.98
KA 102	9.57	11.06	11.38	1.97	7.38	0.51	0.98
KA 102	10.55	12.05	12.36	1.97	7.38	0.51	0.98
KA 102	11.54	13.03	13.35	1.97	7.38	0.51	0.98
KA 102	12.52	14.02	14.33	1.97	7.38	0.51	0.98
KA 102	13.50	15.00	15.31	1.97	7.38	0.51	0.98
KA 102	14.49	15.98	16.30	1.97	7.38	0.51	0.98
KA 102	16.46	17.95	18.27	1.97	7.38	0.51	0.98
KA 102	18.43	19.92	19.25	1.97	7.38	0.51	0.98
KA 102	20.39	22.28	22.20	1.97	7.38	0.51	0.98
KA 102	variable	A+1.50	A+1.81	1.97	7.38	0.51	0.98

Type	A inch	B inch	D inch	F inch	G inch	H Ø inch	I inch
KA 102	4.65	4.72	6.46	1.97	7.38	0.51	0.98
KA 102	5.63	5.71	7.44	1.97	7.38	0.51	0.98
KA 102	6.61	6.69	8.43	1.97	7.38	0.51	0.98
KA 102	7.60	7.68	9.41	1.97	7.38	0.51	0.98
KA 102	8.58	8.58	10.39	1.97	7.38	0.51	0.98
KA 102	9.57	9.65	11.38	1.97	7.38	0.51	0.98
KA 102	10.55	10.63	12.36	1.97	7.38	0.51	0.98
KA 102	11.54	11.61	13.35	1.97	7.38	0.51	0.98
KA 102	12.52	12.60	14.33	1.97	7.38	0.51	0.98
KA 102	13.50	13.58	15.31	1.97	7.38	0.51	0.98
KA 102	14.49	14.75	16.30	1.97	7.38	0.51	0.98
KA 102	16.46	16.54	18.27	1.97	7.38	0.51	0.98
KA 102	18.43	18.50	19.25	1.97	7.38	0.51	0.98
KA 102	20.39	20.47	22.20	1.97	7.38	0.51	0.98
KA 102	variable	A+0.08	A+1.81	1.97	7.38	0.51	0.98

Separator

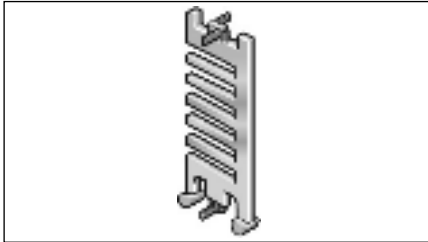

Separator

Type	Order no.	Designation	Lock grid spacing inch	Pack qty.
TR 102	1020000092	Separator	0.20	1

We recommend that separators be used if multiple round cables or conduits with differing diameters are to be installed. An offset configuration of the separators is advisable.

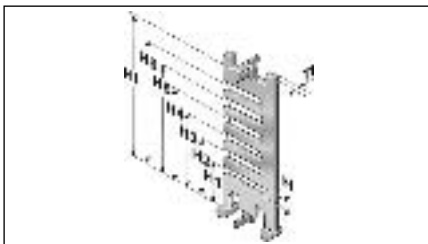

Separator

Type	T1 inch	H inch	H1 inch	H2 inch	H3 inch	H4 inch	H5 inch	H6 inch	H1
TR 102	0.16	0.22	1.08	1.56	2.05	2.53	3.02	3.50	4.09

Shelving system

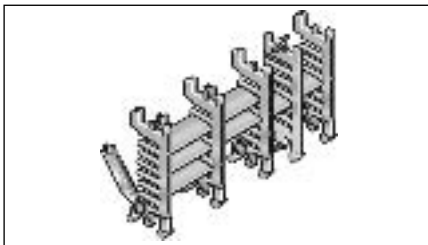

Shelving system

Type	Order no.	Designation	Width inch	Lock grid spacing inch	Pack qty.
RB 056-7	100000005600	RB 056-7 Shelf	2.20	0.20	1
RB 066-7	100000006600	RB 066-7 Shelf	2.60	0.20	1
RB 081-7	100000008100	RB 081-7 Shelf	3.19	0.20	1
RB 106-7	100000010600	RB 106-7 Shelf	4.17	0.20	1
RB 116-7	100000011600	RB 116-7 Shelf	4.57	0.20	1
RB 166-7	100000016600	RB 166-7 Shelf	6.54	0.20	1
RB 216-7	100000021600	RB 216-7 Shelf	8.50	0.20	1
RTT 102	100091022000	RTT 102 Shelf support, divisible		0.20	1

In connection with at least two shelf supports (RTT) the shelf becomes a shelving system. The additional levels prevent cables from criss-crossing and therefore destroying each other, while also avoiding excessive friction. The shelving system may be pre-assembled on request.



Shelving system

Type	T1 inch
RTT 102	0.31



MP 102.2 - Accessories

Crossbar connector

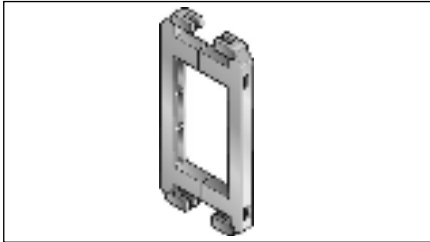

Crossbar connector

Type	Order no.	Designation	Pack qty.
RSV 102	1020000096	RSV 102 Crossbar connector	1
RSV 102 Alu	1020000098	RSV 102 Crossbar connector for aluminum crossbridges	1

For frame bridges wider than 9.69 in (246 mm), we recommend the use of crossbar connectors. These prevent deformation to the frame bridge under large amounts of additional weight of the chain assembly.

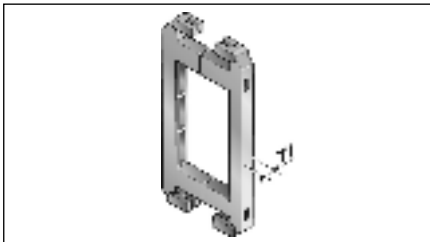

Type	TI inch
RSV 102	0.31
RSV 102 Alu	0.31

Crossbar strain relief plate RS-ZL

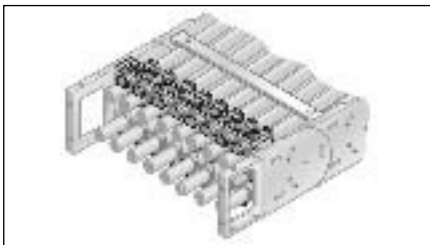

Crossbar strain relief plate RS-ZL

Type	Order no.	For internal width inch	Pack qty.
RS-ZL 118-7	072011800010	4.65	1
RS-ZL 143-7	072014300010	5.63	1
RS-ZL 168-7	072016800010	6.61	1
RS-ZL 193-7	072019300010	7.60	1
RS-ZL 218-7	072021800010	8.58	1
RS-ZL 243-7	072024300010	9.57	1

Fixed integrated frame bridge strain relief plates in the chain brackets. Accommodated to all widths of the frame ridges, up to 9.57 in (243 mm) in size. May be assembled on the inside and outside flexure curves at both chain endings.

Strain relief type BAK

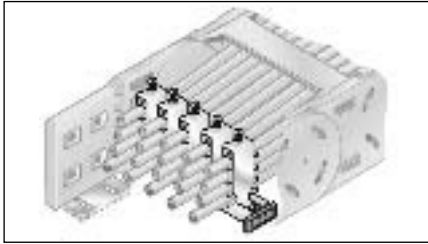

Strain relief with hooped clamp

Type	Order no.	Designation	Ø inch	Number of seats	Pack qty.
C-rail	81661610	C-profile rail			1
BA 12	81661036	BA 12 Hooped clamp	0.35–0.47	1	1
BAK 14	81661002	BAK 14 Hooped clamp	0.24–0.55	1	1
BAK 18	81661004	BAK 18 Hooped clamp	0.55–0.71	1	1
BAK 22	81661006	BAK 22 Hooped clamp	0.71–0.87	1	1
BAK 26	81661008	BAK 26 Hooped clamp	0.87–1.02	1	1
BAK 30	81661010	BAK 30 Hooped clamp	1.02–1.18	1	1
BAK 34	81661000	BAK 34 Hooped clamp	1.18–1.34	1	1
BAK 38	81661044	BAK 38 Hooped clamp	1.34–1.50	1	1
BAK 42	81661032	BAK 42 Hooped clamp	1.50–1.65	1	1
BAK 46	81661050	BAK 46 Hooped clamp	1.65–1.81	1	1
BA 12/2	81661038	BA 12/2 Hooped clamp	0.35–0.47	2	1
BAK 14/2	81661012	BAK 14/2 Hooped clamp	0.39–0.55	2	1
BAK 18/2	81661014	BAK 18/2 Hooped clamp	0.55–0.71	2	1
BAK 22/2	81661016	BAK 22/2 Hooped clamp	0.71–0.87	2	1
BAK 26/2	81661018	BAK 26/2 Hooped clamp	0.87–1.02	2	1
BAK 30/2	81661048	BAK 30/2 Hooped clamp	1.02–1.18	2	1
BAK 34/2	81661044	BAK 34/2 Hooped clamp	1.18–1.34	2	1
BAK 38/2	81661046	BAK 38/2 Hooped clamp	1.34–1.50	2	1
BAK 42/2	81661034	BAK 42/2 Hooped clamp	1.50–1.65	2	1
BAK 12/3	81661020	BAK 12/3 Hooped clamp	0.35–0.47	3	1
BAK 14/3	81661022	BAK 14/3 Hooped clamp	0.47–0.55	3	1
BAK 16/3	81661024	BAK 16/3 Hooped clamp	0.55–0.63	3	1
BAK 18/3	81661026	BAK 18/3 Hooped clamp	0.63–0.71	3	1
BAK 20/3	81661028	BAK 20/3 Hooped clamp	0.71–0.79	3	1
BAK 22/3	81661030	BAK 22/3 Hooped clamp	0.79–0.87	3	1

Fixed integrated strain relief in the chain connections. Available in all widths (also individual widths for aluminum frame ridges). May be assembled on the inside and outside flexure curves at both chain endings. Chain content is secured through hooped clamps that are available in different sizes. Material: Galvanized steel.

When ordering please indicate the type of chain and internal width.



Reverse radius

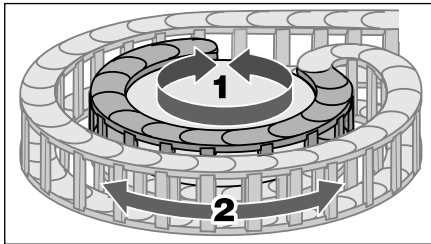

Rotating movement

Type	Order no.	Radius inch	Reverse radius inch	Pack qty.
SR 102 (RÜ400/R400) left	10200040060	15.75	15.75	1
SR 102 (RÜ400/R400) right	10200040062	15.75	15.75	1

Side links with radius forward (R) and radius backward (Rü) allow for movement in two directions. This is intended for rotating movements and lowered chain brackets.

Note: This type of chain has different chain links for the left or right side!

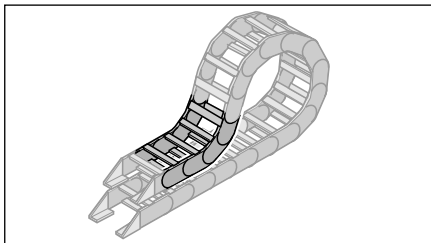

lowered chain bracket

Assembly

Disassembly

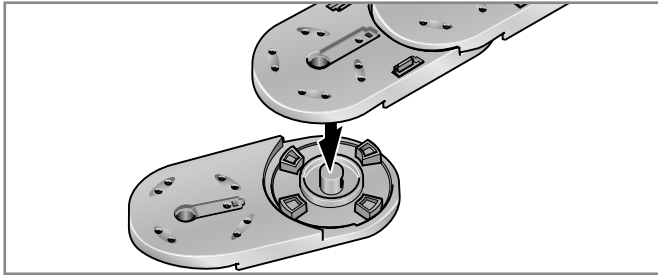

Step 1

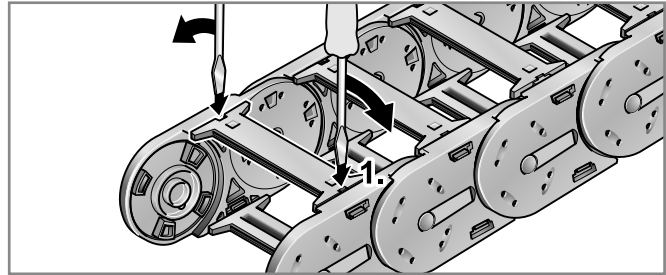

Step 1

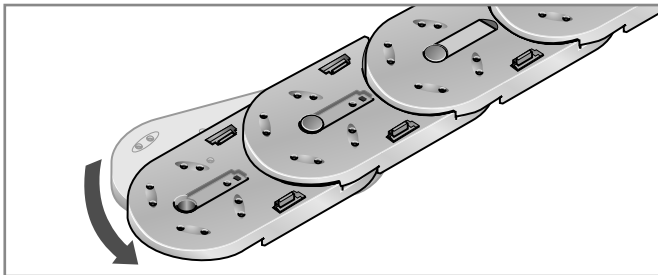

Step 2

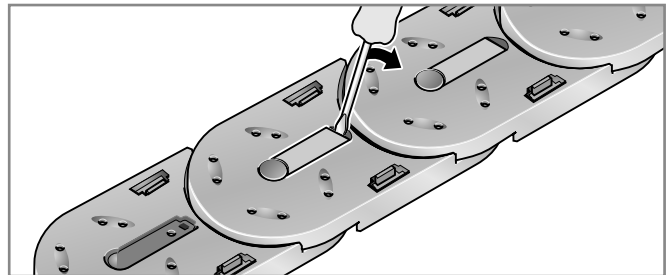

Step 2

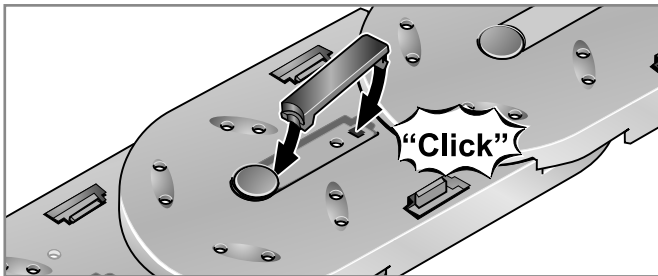

Step 3

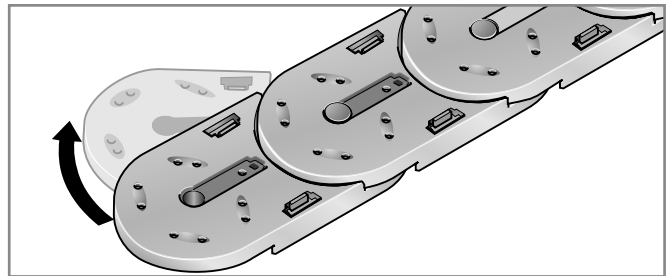

Step 3

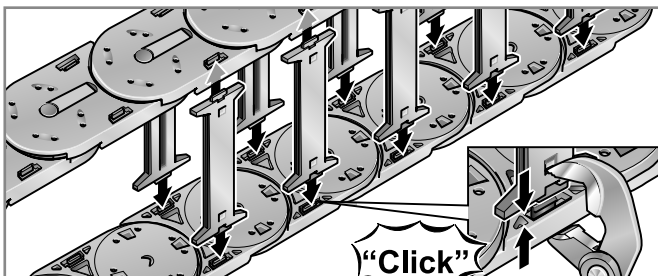

Step 4

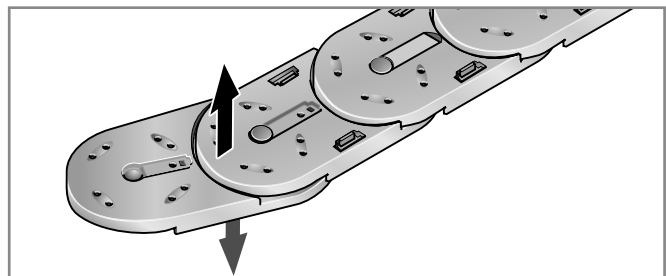

Step 4

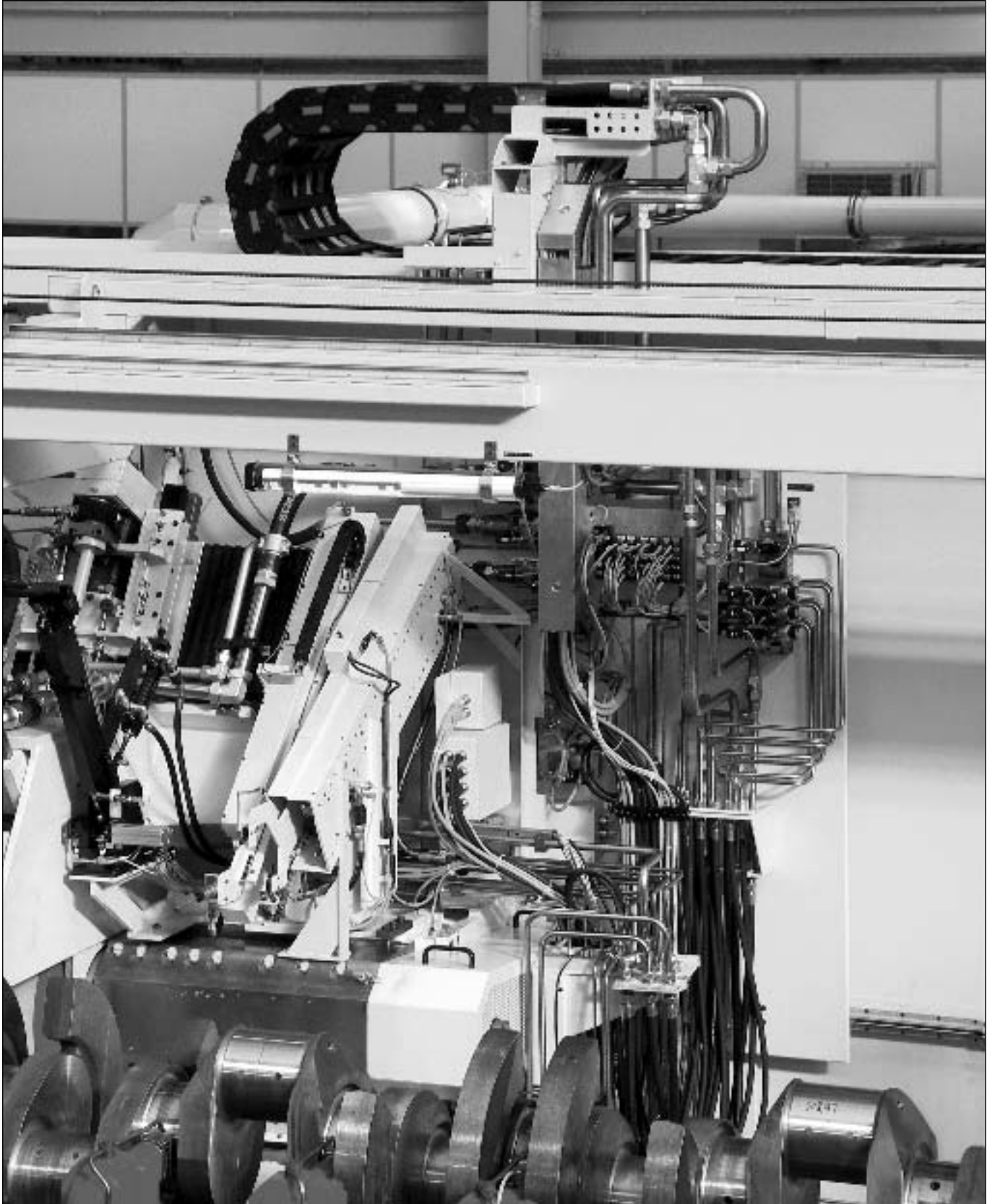

Cable drag chain systems

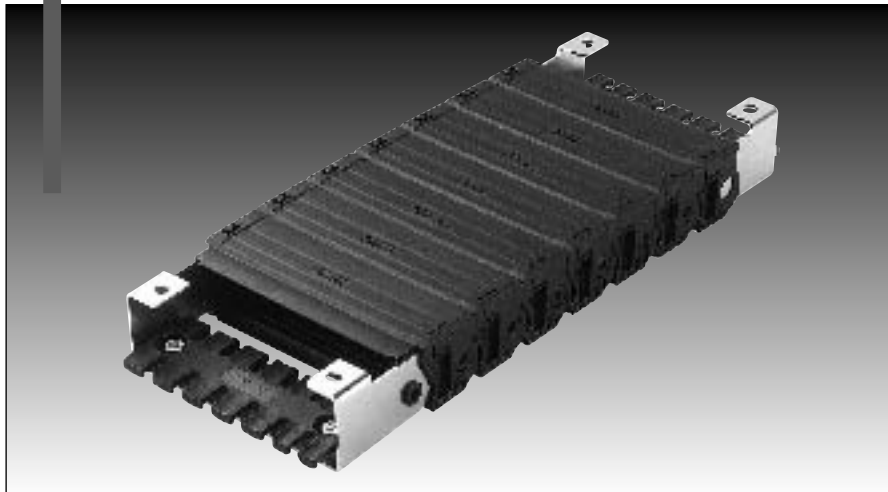

SafeLine

MP 25 G



MP 25 G - SafeLine

Order variants

Style (order code)						
Configuration (order code)						
Radius (order code)						
The radii can be combined with any internal width						
in inch						
Internal width (order code)						
in inch						
Outside width (order code)						
in inch						
MP25 026	1.65	1.02	026	2.36	060	
MP25 037	2.09	1.46	037	2.95	075	
MP25 062	3.07	2.44	062	3.94	100	
MP25 087	4.06	3.43	087	4.92	125	
MP25 101	4.61	3.98	101	5.91	150	0
MP25 125	5.55	4.92	125	7.87	200	7
				9.84	250	9
						0

Order-Number:	0250			0			0
----------------------	-------------	--	--	----------	--	--	----------

Configuration:
 0 PA crossbar every link; w/bias

Style:
 0 Standard (PA/black)
 7 ESD (PA/light gray)
 9 Custom version

Sample order:
 0250 026 060 0000

Internal width = 1.02 in (26 mm)
 Radius = 2.36 in (60 mm)
 Configuration = 0
 Style = 0

Ideal operating conditions:

- Compact dimensions with opening cover in outside bend
- Quiet operation
- High stability
- Flexible internal separation

Alternative chain type:

- MP 3000/MP 26 open version
- MP 36 G Flange connection

Features

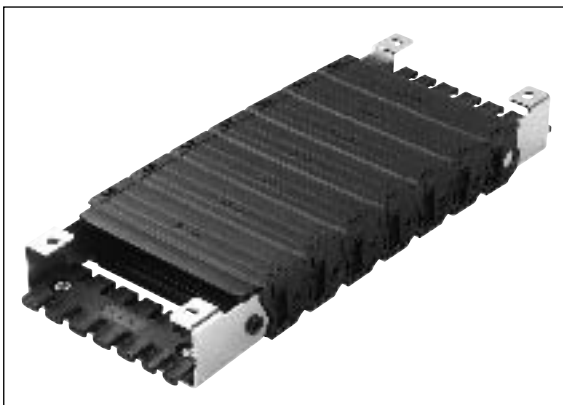

Folding cover for closed cable drag chains



Integrable separator for cable separation



Chain bracket/metal bracket



Radii with medium bias (R) for all applications



Strain relief plate ZL



ESD cable drag chains for use in areas of electrostatic discharge

Technical data

Chain link dimensions (inch) (mm)

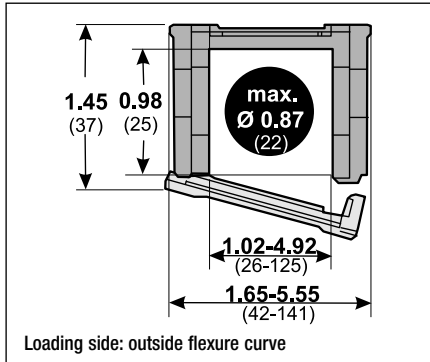

Material characteristics standard (PA/black)

Operating temperature: -22 to 248° F
 Gliding friction factor: 0.30
 Static friction factor: 0.45
 Fire classification: Based on UL94 HB

Other material properties on request

Technical specifications

Travel distance, gliding, L_g : 131.23 ft
 Travel distance, self-supporting, L_s : see diagram
 Travel distance, vertical, hanging, L_{vh} : 82.02 ft
 Travel distance, vertical, upright, L_{vu} : 9.84 ft
 Rotated 90°, self-supporting, L_{90r} : 3.28 ft
 Speed, gliding, V_g : 9.84 ft
 Speed, self-supporting, V_s : 19.69 ft/s
 Acceleration, gliding, a_g : 32.81 ft/s²
 Acceleration, self-supporting, a_s : 49.21 ft/s²

Self-supporting length

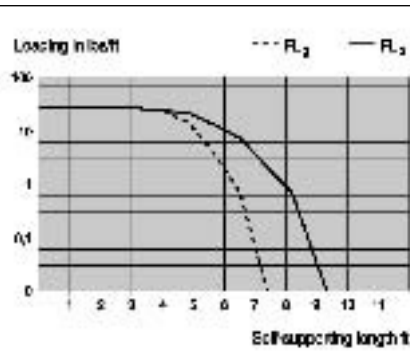
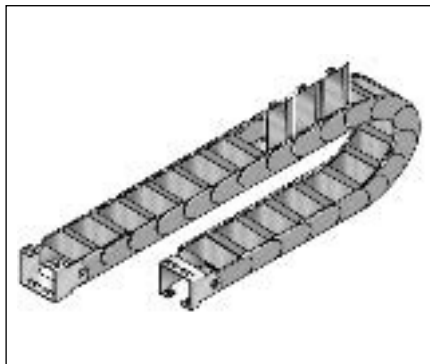

FL₁:
 Ideal installation situation for high stresses at the limit of the max. travel parameters. In this range the chain upper run is still biased, straight or has a max. sag of 0.39 – 1.97 in (10 – 50 mm) depending on the type of chain.

FL₂:
 Satisfactory installation position for many applications working in the lower to middle range of the max. travel parameters. Depending on the chain type, the sag of the chain upper run is >0.39 – 1.97 in (>10 – 50 mm) but certainly less than the max. sag.

If the sag is greater than FL₂, the arrangement is unsuitable and should be avoided. Please choose a more stable Murrplastik cable drag chain.

Determining the chain length

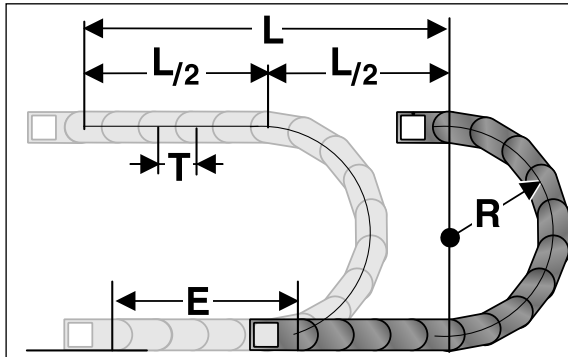

L = Travel distance
 R = Radius
 T = Pitch
 E = Distance between entry point and middle of travel distance

Determining the chain length

$$\text{Length} = \frac{L}{2} + \pi \times R + 2 \times T + E$$

≈ 1 ft(m) chain = 11(33) links each 1.18 in (30 mm)

The fixed point of the cable drag chain should be connected in the middle of the travel distance. This arrangement gives the shortest connection between the fixed point and the moving point and thus the most efficient chain length.

Installation dimensions (in inch)

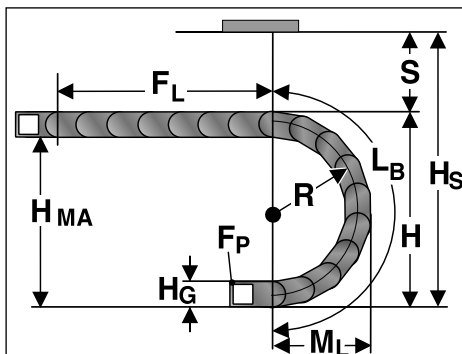

Radius R	2.36	2.95	3.94	4.92	5.91	7.87	9.84
Outside height of chain link (H_o)	1.46	1.46	1.46	1.46	1.46	1.46	1.46
Height of bend (H)	6.18	7.36	9.33	11.30	13.27	17.20	21.14
Height of moving end connection (H_{MA})	4.72	5.91	7.87	9.84	11.81	15.75	19.69
Safety margin (S)	1.30	1.30	1.30	1.30	1.30	1.30	1.30
Installation height (H_s)	7.48	8.66	10.63	12.60	14.57	18.50	22.44
Arc projection (M_L)	4.25	4.88	5.83	6.85	7.80	9.76	11.73
Bend length (L_b)	10.87	12.76	15.83	18.94	22.01	28.19	34.37



MP 25 G - SafeLine

Chain bracket

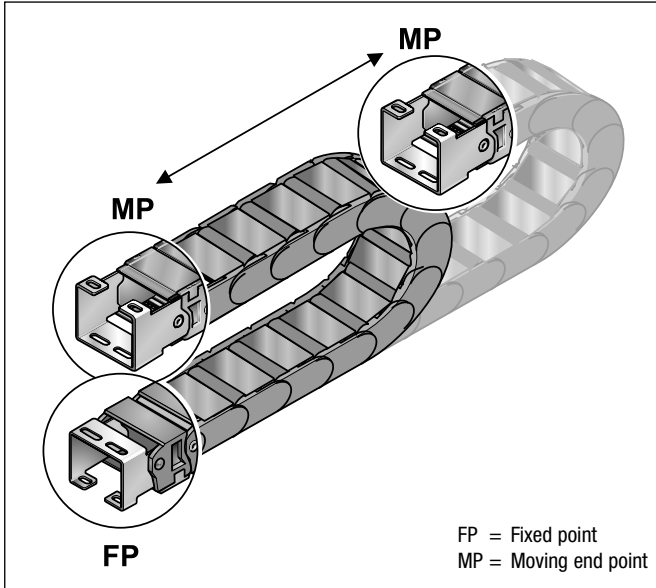

Chain bracket

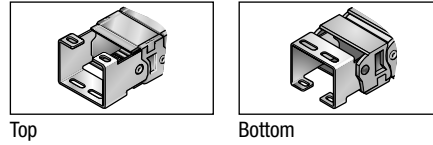

Chain bracket

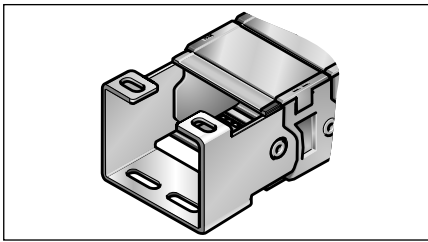

KA 25...

Type	Order no.	Material	Pack qty.
KA 25026 C Female end	025000001000	Sheet steel	1
KA 25026 C Male end	025000001100	Sheet steel	1
KA 25037 C Female end	025000001200	Sheet steel	1
KA 25037 C Male end	025000001300	Sheet steel	1
KA 25062 C Female end	025000001400	Sheet steel	1
KA 25062 C Male end	025000001500	Sheet steel	1
KA 25087 C Female end	025000001600	Sheet steel	1
KA 25087 C Male end	025000001700	Sheet steel	1
KA 25101 C Female end	025000001800	Sheet steel	1
KA 25101 C Male end	025000001900	Sheet steel	1
KA 25125 C Female end	025000002000	Sheet steel	1
KA 25125 C Male end	025000002100	Sheet steel	1
KA 25026 C Female end	025000003000	Stainless steel 1.4301	1
KA 25026 C Male end	025000003100	Stainless steel 1.4301	1
KA 25037 C Female end	025000003200	Stainless steel 1.4301	1
KA 25037 C Male end	025000003300	Stainless steel 1.4301	1
KA 25062 C Female end	025000003400	Stainless steel 1.4301	1
KA 25062 C Male end	025000003500	Stainless steel 1.4301	1
KA 25087 C Female end	025000003600	Stainless steel 1.4301	1
KA 25087 C Male end	025000003700	Stainless steel 1.4301	1
KA 25101 C Female end	025000003800	Stainless steel 1.4301	1
KA 25101 C Male end	025000003900	Stainless steel 1.4301	1
KA 25125 C Female end	025000004000	Stainless steel 1.4301	1
KA 25125 C Male end	025000004100	Stainless steel 1.4301	1

A cable drag chain requires two chain brackets. The U-shaped part connection offers two different fastening possibilities.

Chain bracket

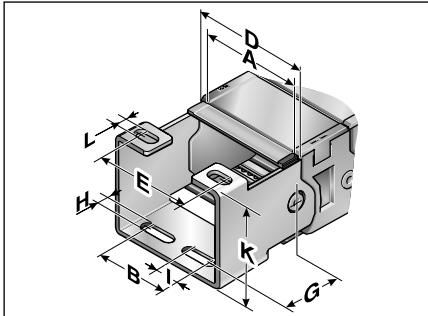

KA 25026-125

Type	A inch	B/E inch	D inch	G inch	H/L inch	I inch	K inch
KA 25026 C Female end	1.02	0.63	1.81	1.65	0.26	0.26	1.42
KA 25026 Male end	1.02	0.63	1.81	1.65	0.26	0.26	1.42
KA 25037 Female end	1.46	1.06	2.24	1.65	0.26	0.28	1.42
KA 25037 Male end	1.46	1.06	2.24	1.65	0.26	0.28	1.42
KA 25062 Female end	2.44	2.05	3.23	1.65	0.26	0.28	1.42
KA 25062 Male end	2.44	2.05	3.23	1.65	0.26	0.28	1.42
KA 25087 Female end	3.43	3.03	4.21	1.65	0.26	0.28	1.42
KA 25087 Male end	3.43	3.03	4.21	1.65	0.26	0.28	1.42
KA 25101 Female end	3.98	3.58	4.76	1.65	0.26	0.28	1.42
KA 25101 Male end	3.98	3.58	4.76	1.65	0.26	0.28	1.42
KA 25125 Female end	4.92	4.53	5.71	1.65	0.26	0.28	1.42
KA 25125 Male end	4.92	4.53	5.71	1.65	0.26	0.28	1.42

Separator

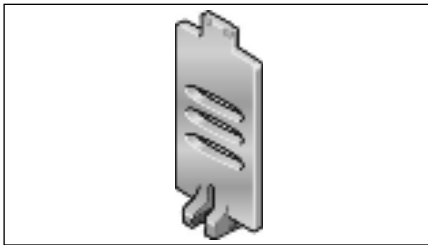

Separator

Type	Order no.	Designation	Lock grid spacing inch	Pack qty.
TR 25G	025000009200	Separator	0.10	1

We recommend that separators be used if multiple round cables or conduits with differing diameters are to be installed. An offset configuration of the separators is advisable.

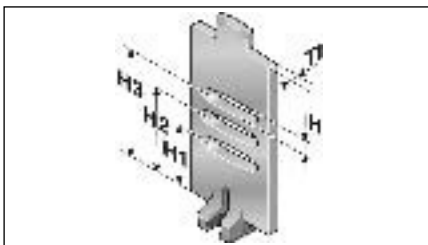

Separator

Type	T1 inch	H inch	H1 inch	H2 inch	H3 inch
TR 25G	0.08	0.10	0.33	0.50	0.68

Shelving system

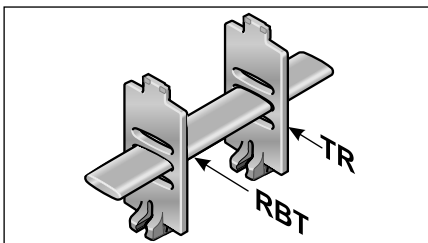

Shelving system

Type	Order no.	Designation	Width inch	Lock grid spacing inch	Pack qty.
RBT 037	100000003700	RBT 037 shelf	1.46	0.10	1
RBT 062	100000006200	RBT 062 shelf	2.44	0.10	1
RBT 086	100000008600	RBT 086 shelf	3.39	0.10	1
RBT 101	100000010100	RBT 101 shelf	3.98	0.10	1
RBT 125	100000012500	RBT 125 shelf	4.92	0.10	1

The shelf must be used with a minimum of two separators to create a shelving system. The additional levels prevent cables from criss-crossing and therefore destroying each other, while also avoiding excessive friction. The shelves are matched to the available chain widths.



MP 25 G - Accessories

Assembly

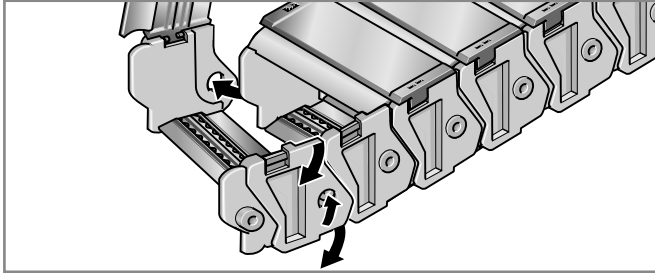

Step 1

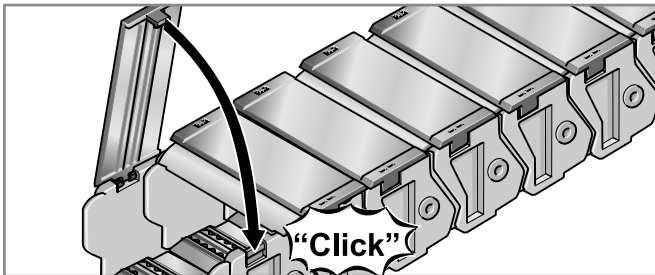

Step 2

Disassembly

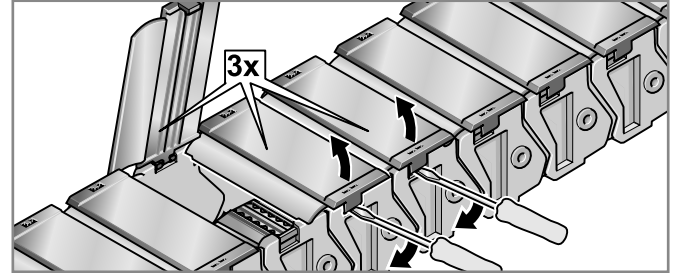

Step 1

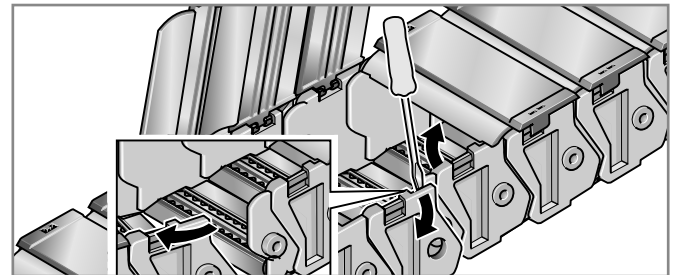

Step 2

Cable drag chain systems

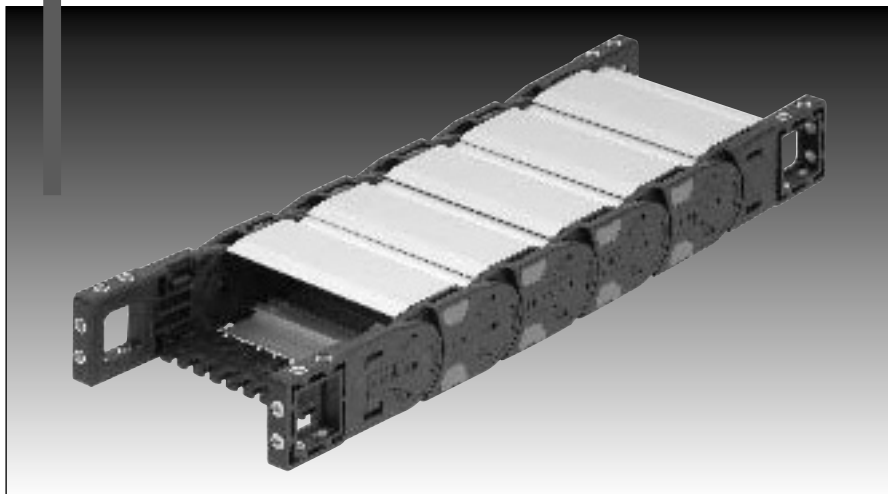

ClosedLine

MP 32.3 G



MP 32.3 G - ClosedLine

Order variants

Style (order code)					
Configuration (order code)					
Radius (order code) in mm					
The radii can be combined with any internal width					
Internal width (order code) in mm					
Outside width (order code) in mm					
MP32.3G 071	3.82	2.80	071		
MP32.3G 084	4.33	3.31	084		
MP32.3G 096	4.80	3.78	096		
MP32.3G 107	5.24	4.21	107		
MP32.3G 121	5.79	4.76	121		
MP32.3G 133	6.26	5.24	133		
MP32.3G 144	6.69	5.67	144		
MP32.3G 146	6.77	5.75	146		
MP32.3G 158	7.24	6.22	158		
MP32.3G 171	7.76	6.73	171		
MP32.3G 182	8.19	7.17	182		
MP32.3G 196	8.74	7.72	196		
MP32.3G 220	9.69	8.66	220		
MP32.3G 246	10.71	9.69	246		
MP32.3G 296	12.68	11.65	296	4.72	120
MP32.3G 346	14.65	13.62	346	5.91	150
MP32.3G xxx	inside + 1.02	>3.78	Alu	7.87	200
		-23.62		9.84	250
					4
					0
					9

Order-Number:

Configuration:
4 AL crossbar every link; w/bias

Style:
0 Standard (PA/black)
9 Custom version

Sample order:
0323 071 120 0400

Internal width = 2.80 in (71 mm)
Radius = 4.72 in (120 mm)
Configuration = 4
Style = 0

Ideal operating conditions:

- Extremely high accelerations
- Extremely high speeds
- Very high additional loads
- Long travel distances
- Extreme self-supporting lengths

Alternative chain type:

- MP 32.2 open series
- MP 36G for easier applications, opens toward inner bend

Features

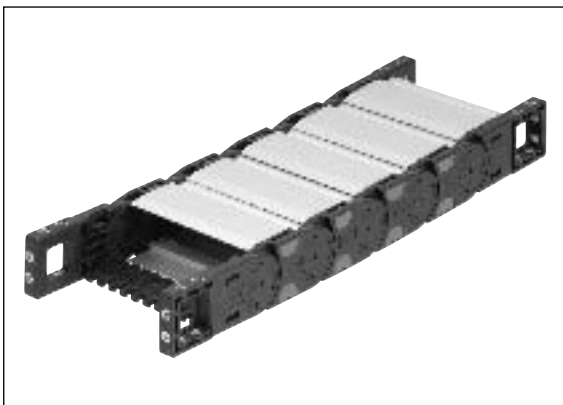

- Chain bracket, can be fastened on three sides
- Side links with CLICK lock for easy opening
- Crossbar strain relief can be integrated into chain bracket
- C-profile rail can be integrated into chain bracket
- Foldable shelf system for reliable cable guidance
- Crossbar/cover can be removed from inside and outside flexure curve
- Radii with medium bias (R) for all applications
- Aluminum frame bridges with integrated lock grid in variable lengths
- Integrable separator for cable separation

Technical data

Chain link dimensions (inch) (mm)

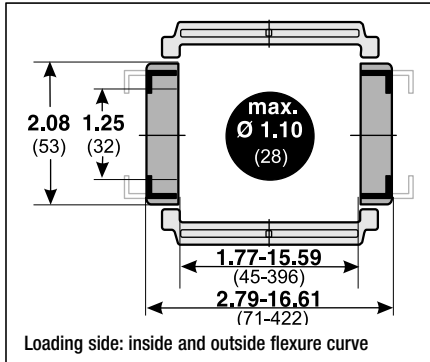

Material characteristics standard (PA/black)

Operating temperature: -22 to 248° F
 Gliding friction factor: 0.30
 Static friction factor: 0.45
 Fire classification: Based on UL94 HB

Other material properties on request

Technical specifications

Travel distance, gliding, L_g : 328.08 ft
 Travel distance, self-supporting, L_s : see diagram
 Travel distance, vertical, hanging, L_{vs} : 196.85 ft
 Travel distance, vertical, upright, L_{vs} : 16.40 ft
 Rotated 90°, self-supporting, L_{90r} : 3.28 ft
 Speed, gliding, V_g : 16.40 ft/s
 Speed, self-supporting, V_r : 65.62 ft/s
 Acceleration, gliding, a_g : 82.02 ft/s²
 Acceleration, self-supporting, a_s : 98.43 ft/s²

Self-supporting length

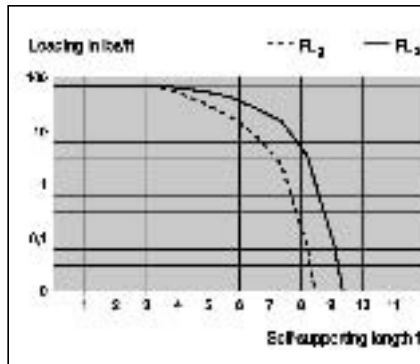
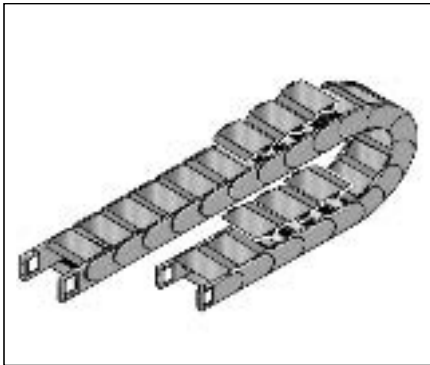

Determining the chain length

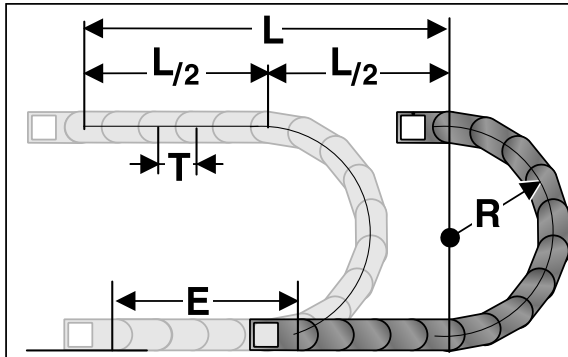

Determining the chain length

$$\text{Length} = \frac{L}{2} + \pi \times R + E$$

≈ 1 ft(m) chain = 5(16) links each 2.54 in (64,5 mm)

The fixed point of the cable drag chain should be connected in the middle of the travel distance. This arrangement gives the shortest connection between the fixed point and the moving point and thus the most efficient chain length.

Installation dimensions (in inch)

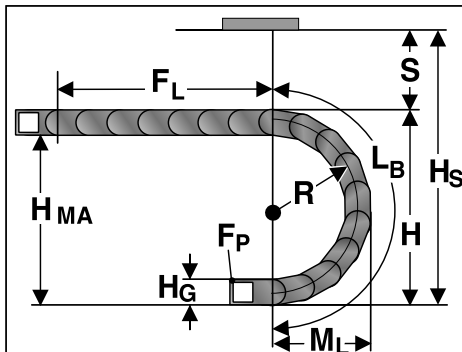

Radius R	4.72	5.91	7.87	9.84
Outside height of chain link (H_o)	2.09	2.09	2.09	2.09
Height of bend (H)	12.32	14.96	18.62	22.56
Height of moving end connection (H_{MA})	10.24	12.60	16.54	20.47
Safety margin (S)	1.18	1.18	1.18	1.18
Installation height (H_s)	13.50	15.87	19.80	23.74
Arc projection (M_b)	8.70	9.88	11.85	13.82
Bend length (L_b)	21.89	25.59	31.77	37.95



MP 32.3 G - ClosedLine

Chain bracket

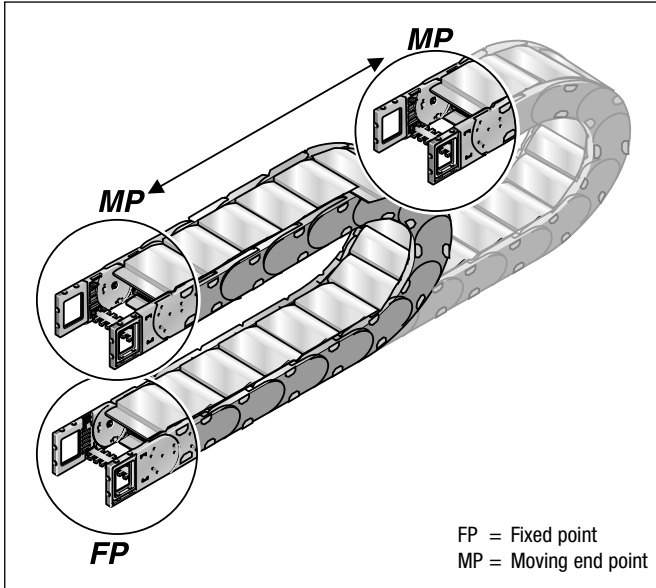

Flexible chain bracket

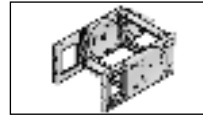

Flexible chain bracket

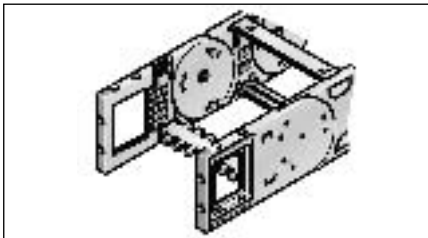

Type	Order no.	Version	Pack qty.
KA 32-FB	0321000054	with bushing	1
KA 32-FG	0321000055	with thread	1

This chain bracket offers universal connection options (top, bottom and front) and is attached to the ends of the chain like a side link. This allows the chain to move right up to the bracket. Each chain requires one male and one female bracket. M5 screws are used to secure the brackets in place. Extrusion-coated metal bushings with either a through-hole (-FB) or a threaded hole (-FG) ensure the permanent, high-strength transmission of even extreme forces onto the cable drag chain.

Flexible chain bracket

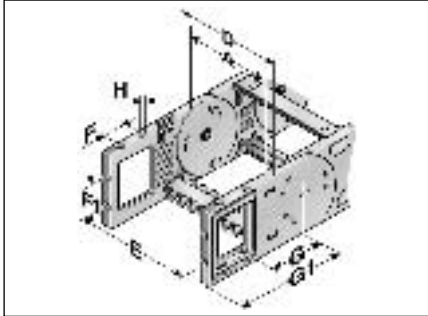

Flexible with through-hole

Type	A inch	D inch	E inch	F inch	F1 inch	G inch	G1 inch	H Ø inch
KA32-FB	2.80	3.82	3.50	0.89	0.87	2.28	3.66	0.22
KA32-FB	3.31	4.33	3.86	0.89	0.87	2.28	3.66	0.22
KA32-FB	3.78	4.80	4.33	0.89	0.87	2.28	3.66	0.22
KA32-FB	4.21	5.24	4.76	0.89	0.87	2.28	3.66	0.22
KA32-FB	4.76	5.79	5.31	0.89	0.87	2.28	3.66	0.22
KA32-FB	5.24	6.26	5.79	0.89	0.87	2.28	3.66	0.22
KA32-FB	5.67	6.69	6.22	0.89	0.87	2.28	3.66	0.22
KA32-FB	5.75	6.77	6.30	0.89	0.87	2.28	3.66	0.22
KA32-FB	6.22	7.24	6.77	0.89	0.87	2.28	3.66	0.22
KA32-FB	6.73	7.76	7.28	0.89	0.87	2.28	3.66	0.22
KA32-FB	7.17	8.19	7.72	0.89	0.87	2.28	3.66	0.22
KA32-FB	7.72	8.74	8.27	0.89	0.87	2.28	3.66	0.22
KA32-FB	8.66	9.69	9.21	0.89	0.87	2.28	3.66	0.22
KA32-FB	9.69	10.71	10.24	0.89	0.87	2.28	3.66	0.22
KA32-FB	11.65	12.68	12.20	0.89	0.87	2.28	3.66	0.22
KA32-FB	13.62	14.65	14.17	0.89	0.87	2.28	3.66	0.22

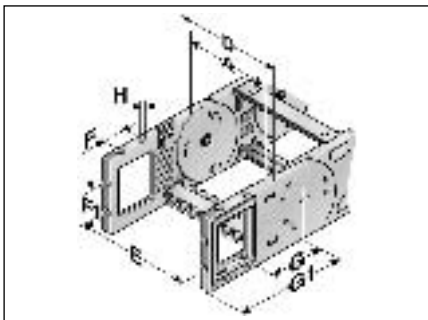

Flexible with threaded bushing

Type	A inch	D inch	E inch	F inch	F1 inch	G inch	G1 inch	H
KA32-FG	2.80	3.82	3.50	0.89	0.87	2.28	3.66	M5
KA32-FG	3.31	4.33	3.86	0.89	0.87	2.28	3.66	M5
KA32-FG	3.78	4.80	4.33	0.89	0.87	2.28	3.66	M5
KA32-FG	4.21	5.24	4.76	0.89	0.87	2.28	3.66	M5
KA32-FG	4.76	5.79	5.31	0.89	0.87	2.28	3.66	M5
KA32-FG	5.24	6.26	5.79	0.89	0.87	2.28	3.66	M5
KA32-FG	5.67	6.69	6.22	0.89	0.87	2.28	3.66	M5
KA32-FG	5.75	6.77	6.30	0.89	0.87	2.28	3.66	M5
KA32-FG	6.22	7.24	6.77	0.89	0.87	2.28	3.66	M5
KA32-FG	6.73	7.76	7.28	0.89	0.87	2.28	3.66	M5
KA32-FG	7.17	8.19	7.72	0.89	0.87	2.28	3.66	M5
KA32-FG	7.72	8.74	8.27	0.89	0.87	2.28	3.66	M5
KA32-FG	8.66	9.69	9.21	0.89	0.87	2.28	3.66	M5
KA32-FG	9.69	10.71	10.24	0.89	0.87	2.28	3.66	M5
KA32-FG	11.65	12.68	12.20	0.89	0.87	2.28	3.66	M5
KA32-FG	13.62	14.65	14.17	0.89	0.87	2.28	3.66	M5



MP 32.3 G - Accessories

Separator

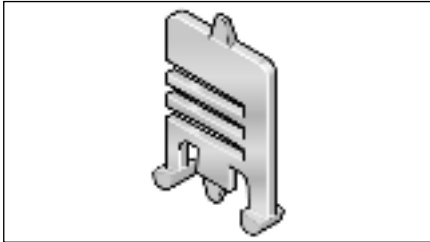

Separator

Type	Order no.	Designation	Lock grid spacing inch	Pack qty.
TR 1.26	032200009200	Separator	0.22	1

We recommend that separators be used if multiple round cables or conduits with differing diameters are to be installed. An offset configuration of the separators is advisable.

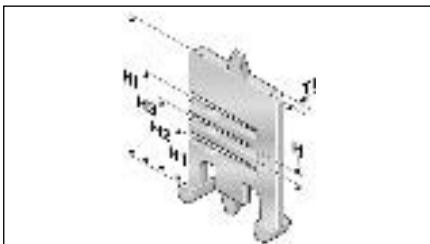

Separator

Type	T1 inch	H inch	H1 inch	H2 inch	H3 inch	HI inch
TR 1.26	0.14	0.16	0.33	0.57	0.81	1.26

Shelving system

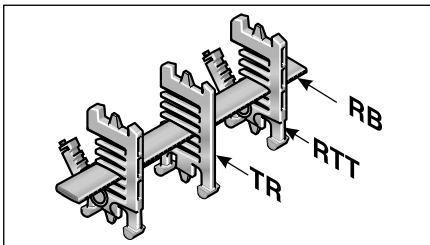

Shelving system

Type	Order no.	Designation	Width inch	Lock grid spacing inch	Pack qty.
RB 028-5	100000002800	RB 028-5 Shelf	1.10	0.22	1
RB 056-5	100000005600	RB 056-5 Shelf	2.20	0.22	1
RB 084-5	100000008400	RB 084-5 Shelf	3.31	0.22	1
RB 112-5	100000011200	RB 112-5 Shelf	4.41	0.22	1
RB 140-5	100000014000	RB 140-5 Shelf	5.51	0.22	1
RB 168-5	100000016800	RB 168-5 Shelf	6.61	0.22	1
RB 196-5	100000019600	RB 196-5 Shelf	7.72	0.22	1
RTT 32	100090322000	RTT 32 Shelf support, divisible		0.22	1

In connection with at least two shelf supports (RTT) the shelf becomes a shelving system. The additional levels prevent cables from criss-crossing and therefore destroying each other, while also avoiding excessive friction. Pre-assembly is not necessary as the shelving system and cabling can be assembled quickly and easily on site.

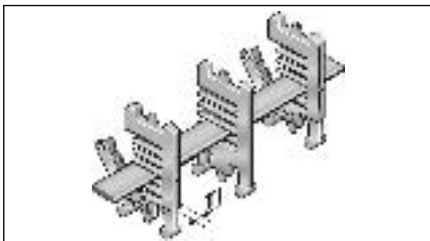

Shelving system

Type	T1 inch
RTT 32	0.28

Chain bracket cover D3

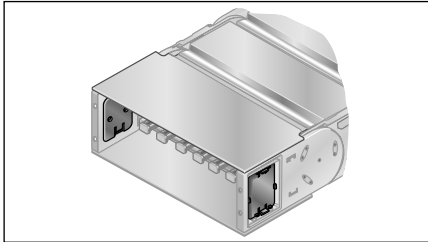

Side link cover

Type	Order no.	Pack qty.
Cover D3 KA 1.26-FB/FG	0323888002	2

Self-locking covers close the side mounting window on the flexible chain bracket (KA-FB/FG).

Chain bracket cover

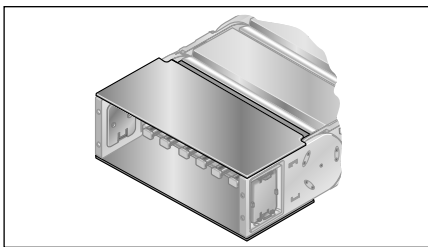

Covers for the flexible chain bracket (KA-FB/FG) allow for a closed variant up to the chain's end.

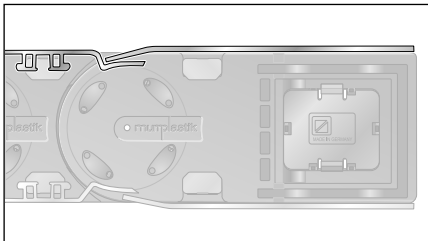

outside flexure curve

Type	Order no.	Inside width inch	Material	Pack qty.
Cover KA 32 FB/FG AB 062 1-2	0321062059	2.44	Anodized aluminum	1
Cover KA 32 FB/FG AB 071 1-2	0321071059	2.80	Anodized aluminum	1
Cover KA 32 FB/FG AB 084 1-2	0321084059	3.31	Anodized aluminum	1
Cover KA 32 FB/FG AB 096 1-2	0321096059	3.78	Anodized aluminum	1
Cover KA 32 FB/FG AB 107 1-2	0321107059	4.21	Anodized aluminum	1
Cover KA 32 FB/FG AB 121 1-2	0321121059	4.76	Anodized aluminum	1
Cover KA 32 FB/FG AB 133 1-2	0321133059	5.24	Anodized aluminum	1
Cover KA 32 FB/FG AB 144 1-2	0321144059	5.67	Anodized aluminum	1
Cover KA 32 FB/FG AB 146 1-2	0321146059	5.75	Anodized aluminum	1
Cover KA 32 FB/FG AB 158 1-2	0321158059	6.22	Anodized aluminum	1
Cover KA 32 FB/FG AB 171 1-2	0321171059	6.73	Anodized aluminum	1
Cover KA 32 FB/FG AB 182 1-2	0321182059	7.17	Anodized aluminum	1
Cover KA 32 FB/FG AB 196 1-2	0321196059	7.72	Anodized aluminum	1
Cover KA 32 FB/FG AB 220 1-2	0321220059	8.66	Anodized aluminum	1
Cover KA 32 FB/FG AB 246 1-2	0321246059	9.69	Anodized aluminum	1
Cover KA 32 FB/FG AB 296 1-2	0321296059	11.65	Anodized aluminum	1
Cover KA 32 FB/FG AB 346 1-2	0321346059	13.62	Anodized aluminum	1
Cover KA 32 FB/FG AB 396 1-2	0321396059	15.59	Anodized aluminum	1



MP 32.3 G - Accessories

Chain bracket cover

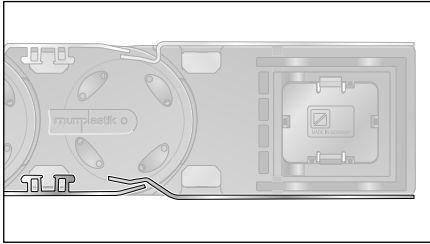

outside flexure curve

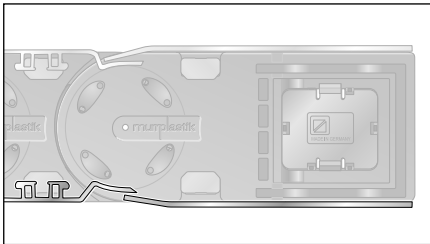

inside flexure curve

Type	Order no.	Inside width inch	Material	Pack qty.
Cover KA 32 FB/FG AB 062 2-2	0321062060	2.44	Anodized aluminum	1
Cover KA 32 FB/FG AB 071 2-2	0321071060	2.80	Anodized aluminum	1
Cover KA 32 FB/FG AB 084 2-2	0321084060	3.31	Anodized aluminum	1
Cover KA 32 FB/FG AB 096 2-2	0321096060	3.78	Anodized aluminum	1
Cover KA 32 FB/FG AB 107 2-2	0321107060	4.21	Anodized aluminum	1
Cover KA 32 FB/FG AB 121 2-2	0321121060	4.76	Anodized aluminum	1
Cover KA 32 FB/FG AB 133 2-2	0321133060	5.24	Anodized aluminum	1
Cover KA 32 FB/FG AB 144 2-2	0321144060	5.67	Anodized aluminum	1
Cover KA 32 FB/FG AB 146 2-2	0321146060	5.75	Anodized aluminum	1
Cover KA 32 FB/FG AB 158 2-2	0321158060	6.22	Anodized aluminum	1
Cover KA 32 FB/FG AB 171 2-2	0321171060	6.73	Anodized aluminum	1
Cover KA 32 FB/FG AB 182 2-2	0321182060	7.17	Anodized aluminum	1
Cover KA 32 FB/FG AB 196 2-2	0321196060	7.72	Anodized aluminum	1
Cover KA 32 FB/FG AB 220 2-2	0321220060	8.66	Anodized aluminum	1
Cover KA 32 FB/FG AB 246 2-2	0321246060	9.69	Anodized aluminum	1
Cover KA 32 FB/FG AB 296 2-2	0321296060	11.65	Anodized aluminum	1
Cover KA 32 FB/FG AB 346 2-2	0321346060	13.62	Anodized aluminum	1
Cover KA 32 FB/FG AB 396 2-2	0321396060	15.59	Anodized aluminum	1

Type	Order no.	Inside width inch	Material	Pack qty.
Cover KA 32 FB/FG IB 062 1-2	0321062057	2.44	Anodized aluminum	1
Cover KA 32 FB/FG IB 071 1-2	0321071057	2.80	Anodized aluminum	1
Cover KA 32 FB/FG IB 084 1-2	0321084057	3.31	Anodized aluminum	1
Cover KA 32 FB/FG IB 096 1-2	0321096057	3.78	Anodized aluminum	1
Cover KA 32 FB/FG IB 107 1-2	0321107057	4.21	Anodized aluminum	1
Cover KA 32 FB/FG IB 121 1-2	0321121057	4.76	Anodized aluminum	1
Cover KA 32 FB/FG IB 133 1-2	0321133057	5.24	Anodized aluminum	1
Cover KA 32 FB/FG IB 144 1-2	0321144057	5.67	Anodized aluminum	1
Cover KA 32 FB/FG IB 146 1-2	0321146057	5.75	Anodized aluminum	1
Cover KA 32 FB/FG IB 158 1-2	0321158057	6.22	Anodized aluminum	1
Cover KA 32 FB/FG IB 171 1-2	0321171057	6.73	Anodized aluminum	1
Cover KA 32 FB/FG IB 182 1-2	0321182057	7.17	Anodized aluminum	1
Cover KA 32 FB/FG IB 196 1-2	0321196057	7.72	Anodized aluminum	1
Cover KA 32 FB/FG IB 220 1-2	0321220057	8.66	Anodized aluminum	1
Cover KA 32 FB/FG IB 246 1-2	0321246057	9.69	Anodized aluminum	1
Cover KA 32 FB/FG IB 296 1-2	0321296057	11.65	Anodized aluminum	1
Cover KA 32 FB/FG IB 346 1-2	0321346057	13.62	Anodized aluminum	1
Cover KA 32 FB/FG IB 396 1-2	0321396057	15.59	Anodized aluminum	1

Chain bracket cover

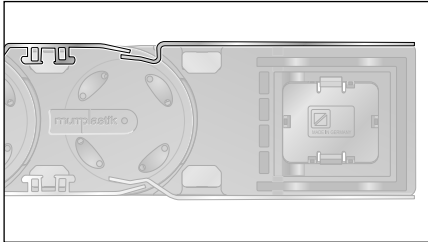

inside flexure curve

Type	Order no.	Inside width inch	Material	Pack qty.
Cover KA 32 FB/FG IB 062 2-2	0321062058	2.44	Anodized aluminum	1
Cover KA 32 FB/FG IB 071 2-2	0321071058	2.80	Anodized aluminum	1
Cover KA 32 FB/FG IB 084 2-2	0321084058	3.31	Anodized aluminum	1
Cover KA 32 FB/FG IB 096 2-2	0321096058	3.78	Anodized aluminum	1
Cover KA 32 FB/FG IB 107 2-2	0321107058	4.21	Anodized aluminum	1
Cover KA 32 FB/FG IB 121 2-2	0321121058	4.76	Anodized aluminum	1
Cover KA 32 FB/FG IB 133 2-2	0321133058	5.24	Anodized aluminum	1
Cover KA 32 FB/FG IB 144 2-2	0321144058	5.67	Anodized aluminum	1
Cover KA 32 FB/FG IB 146 2-2	0321146058	5.75	Anodized aluminum	1
Cover KA 32 FB/FG IB 158 2-2	0321158058	6.22	Anodized aluminum	1
Cover KA 32 FB/FG IB 171 2-2	0321171058	6.73	Anodized aluminum	1
Cover KA 32 FB/FG IB 182 2-2	0321182058	7.17	Anodized aluminum	1
Cover KA 32 FB/FG IB 196 2-2	0321196058	7.72	Anodized aluminum	1
Cover KA 32 FB/FG IB 220 2-2	0321220058	8.66	Anodized aluminum	1
Cover KA 32 FB/FG IB 246 2-2	0321246058	9.69	Anodized aluminum	1
Cover KA 32 FB/FG IB 296 2-2	0321296058	11.65	Anodized aluminum	1
Cover KA 32 FB/FG IB 346 2-2	0321346058	13.62	Anodized aluminum	1
Cover KA 32 FB/FG IB 396 2-2	0321396058	15.59	Anodized aluminum	1

Crossbar strain relief plate RS-ZL

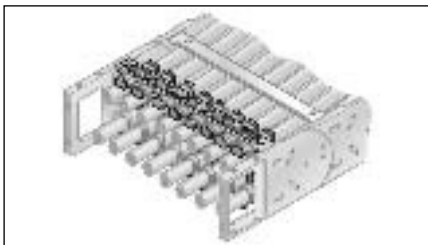

Crossbar strain relief plate RS-ZL

Type	Order no.	For internal width inch	Pack qty.
RS-ZL 045-5	052004500010	1.77	1
RS-ZL 062-5	052006200010	2.44	1
RS-ZL 071-5	052007100010	2.80	1
RS-ZL 084-5	052008400010	3.31	1
RS-ZL 096-5	052009600010	3.78	1
RS-ZL 107-5	052010700010	4.21	1
RS-ZL 121-5	052012100010	4.76	1
RS-ZL 133-5	052013300010	5.24	1
RS-ZL 5.67/5.75-5	052014400010	5.67/5.75	1
RS-ZL 158-5	052015800010	6.22	1
RS-ZL 171-5	052017100010	6.73	1
RS-ZL 182-5	052018200010	7.17	1
RS-ZL 196-5	052019600010	7.72	1
RS-ZL 220-5	052022000010	8.66	1
RS-ZL 246-5	052024600010	9.69	1

Fixed integrated frame bridge strain relief plates in the chain brackets. Tailored to all frame bridge widths up to 9.69 in (246 mm). May be assembled on the inside and outside flexure curves at both chain endings.



MP 32.3 G - Accessories

Strain relief type BAK

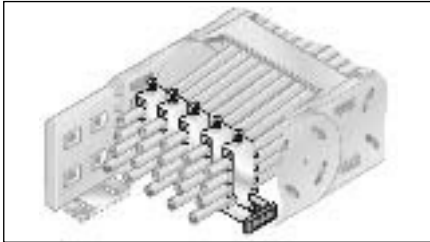

Strain relief with hooped clamp

Type	Order no.	Designation	Ø inch	Number of seats	Pack qty.
C-rail	81661610	C-profile rail			1
BA 12	81661036	BA 12 Hooped clamp	0.35–0.47	1	1
BAK 14	81661002	BAK 14 Hooped clamp	0.24–0.55	1	1
BAK 18	81661004	BAK 18 Hooped clamp	0.55–0.71	1	1
BAK 22	81661006	BAK 22 Hooped clamp	0.71–0.87	1	1
BAK 26	81661008	BAK 26 Hooped clamp	0.87–1.02	1	1
BAK 30	81661010	BAK 30 Hooped clamp	1.02–1.18	1	1
BAK 34	81661000	BAK 34 Hooped clamp	1.18–1.34	1	1
BAK 38	81661044	BAK 38 Hooped clamp	1.34–1.50	1	1
BAK 42	81661032	BAK 42 Hooped clamp	1.50–1.65	1	1
BAK 46	81661050	BAK 46 Hooped clamp	1.65–1.81	1	1
BA 12/2	81661038	BA 12/2 Hooped clamp	0.35–0.47	2	1
BAK 14/2	81661012	BAK 14/2 Hooped clamp	0.39–0.55	2	1
BAK 18/2	81661014	BAK 18/2 Hooped clamp	0.55–0.71	2	1
BAK 22/2	81661016	BAK 22/2 Hooped clamp	0.71–0.87	2	1
BAK 26/2	81661018	BAK 26/2 Hooped clamp	0.87–1.02	2	1
BAK 30/2	81661048	BAK 30/2 Hooped clamp	1.02–1.18	2	1
BAK 34/2	81661044	BAK 34/2 Hooped clamp	1.18–1.34	2	1
BAK 38/2	81661046	BAK 38/2 Hooped clamp	1.34–1.50	2	1
BAK 42/2	81661034	BAK 42/2 Hooped clamp	1.50–1.65	2	1
BAK 12/3	81661020	BAK 12/3 Hooped clamp	0.35–0.47	3	1
BAK 14/3	81661022	BAK 14/3 Hooped clamp	0.47–0.55	3	1
BAK 16/3	81661024	BAK 16/3 Hooped clamp	0.55–0.63	3	1
BAK 18/3	81661026	BAK 18/3 Hooped clamp	0.63–0.71	3	1
BAK 20/3	81661028	BAK 20/3 Hooped clamp	0.71–0.79	3	1
BAK 22/3	81661030	BAK 22/3 Hooped clamp	0.79–0.87	3	1

Fixed integrated strain relief in the chain connections. Available in all widths (also individual widths for aluminum frame ridges). May be assembled on the inside and outside flexure curves at both chain endings. Chain content is secured through hooped clamps that are available in different sizes. Material: Galvanized steel.

When ordering please indicate the type of chain and internal width.

Assembly

Disassembly

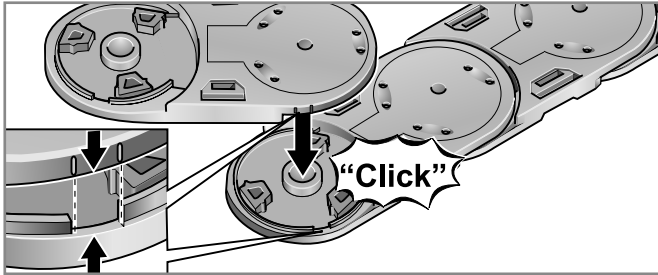

Step 1

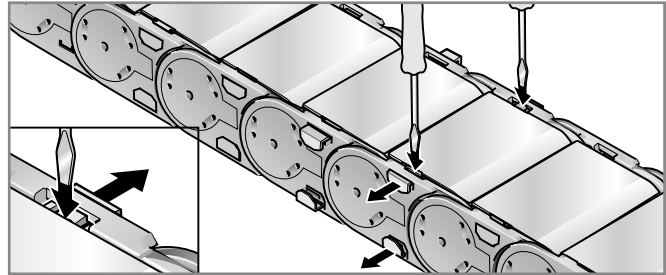

Step 1

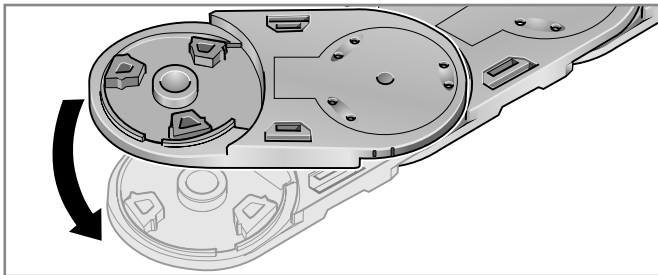

Step 2

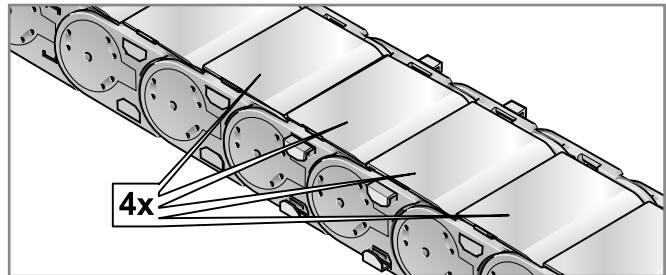

Step 2

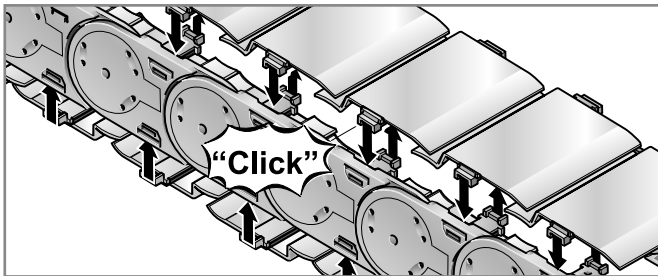

Step 3

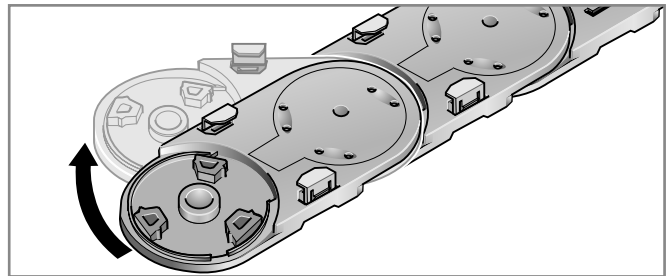

Step 3

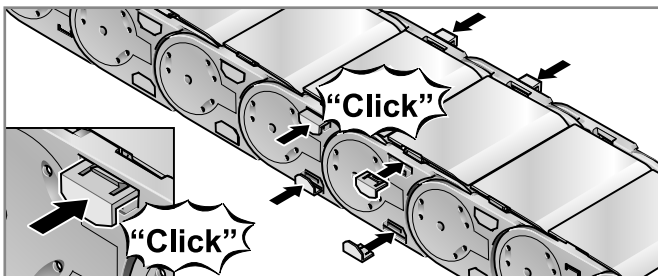

Step 4

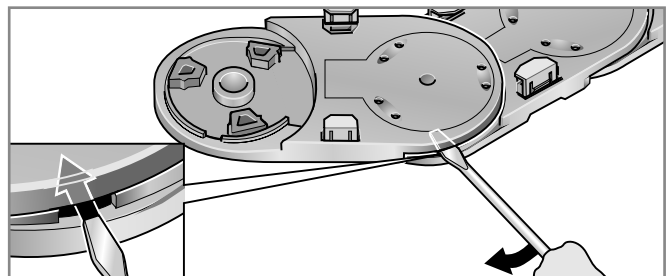

Step 4



Cable drag chain systems

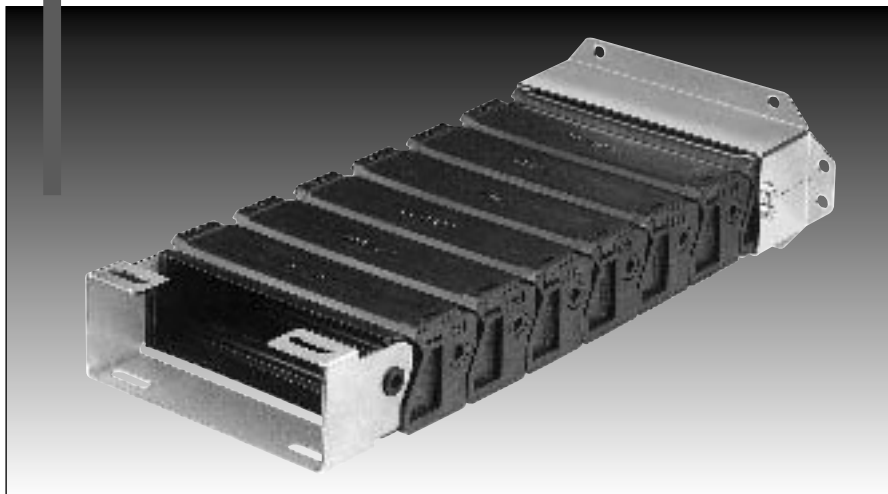

SafeLine

MP 36 G



MP 36 G - SafeLine

Order variants

Style (order code)										
Configuration (order code)										
Radius (order code) <small>The radii can be combined with any internal width</small>										
in inch										
Internal width (order code)										
in inch										
Outside width in inch										
MP36 062	3.07	2.44	062	3.15	080					
MP36 086	4.02	3.39	086	3.94	100					
MP36 102	4.65	4.02	102	4.92	125					
MP36 125	5.55	4.92	125	5.91	150					
				7.87	200				0	9

Order-Number:	0360			0			0
----------------------	-------------	--	--	----------	--	--	----------

Configuration:
 0 PA crossbar every link; w/bias

Style:
 0 Standard (PA/black)
 9 Custom version

Sample order:
 0360 062 080 0000

Internal width = 2.44 in (62 mm)
 Radius = 3.15 in (80 mm)
 Configuration = 0
 Style = 0

Ideal operating conditions:





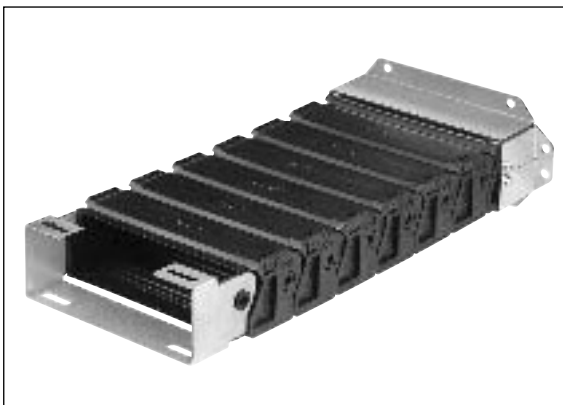

- Compact dimensions with opening cover in inside bend
- Quiet operation
- High stability
- Flexible internal separation

Alternative chain type:

- MP 35 open version

Features



-  Folding cover for closed cable drag chains
-  Integrable separator for cable separation
-  Plug-in shelf system for reliable cable guidance
-  Chain bracket/metal bracket
-  Radii with medium bias (R) for all applications
-  Flange connection for closed cable drag chains
-  Strain relief plate ZL

Technical data

Chain link dimensions (inch) (mm)

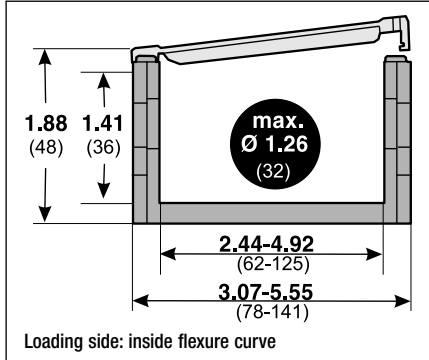

Material characteristics standard (PA/black)

Operating temperature: -22 to 248° F
 Gliding friction factor: 0.30
 Static friction factor: 0.45
 Fire classification: Based on UL94 HB

Other material properties on request

Technical specifications

Travel distance, gliding, L_g : 196.85 ft
 Travel distance, self-supporting, L_s : see diagram
 Travel distance, vertical, hanging, L_{vh} : 98.43 ft
 Travel distance, vertical, upright, L_{vu} : 9.84 ft
 Rotated 90°, self-supporting, L_{90r} : 3.28 ft
 Speed, gliding, V_g : 9.84 ft/s
 Speed, self-supporting, V_s : 32.81 ft/s
 Acceleration, gliding, a_g : 49.21 ft/s²
 Acceleration, self-supporting, a_s : 65.62 ft/s²

Self-supporting length

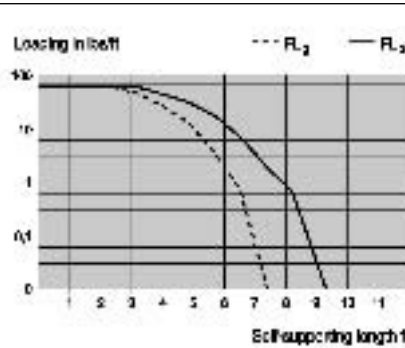
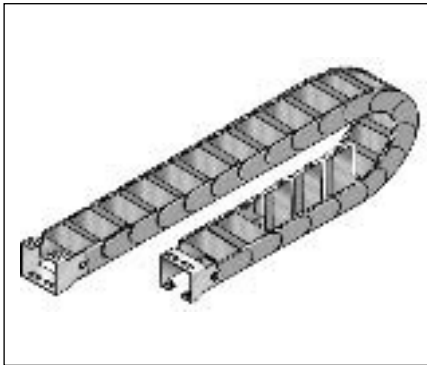

FL₁:
 Ideal installation situation for high stresses at the limit of the max. travel parameters. In this range the chain upper run is still biased, straight or has a max. sag of 0.39 – 1.97 in (10 – 50 mm) depending on the type of chain.

FL₂:
 Satisfactory installation position for many applications working in the lower to middle range of the max. travel parameters. Depending on the chain type, the sag of the chain upper run is >0.39 – 1.97 in (>10 – 50 mm) but certainly less than the max. sag.

If the sag is greater than FL₂, the arrangement is unsuitable and should be avoided. Please choose a more stable Murrplastik cable drag chain.

Determining the chain length

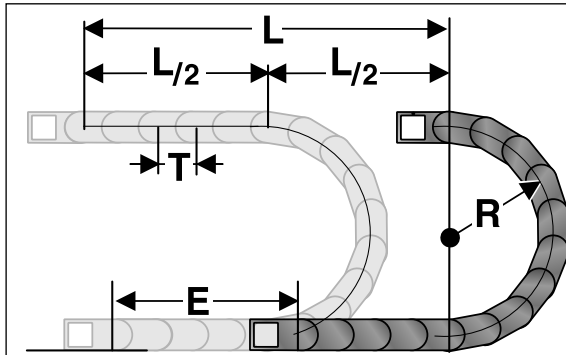

L = Travel distance
 R = Radius
 T = Pitch
 E = Distance between entry point and middle of travel distance

Determining the chain length

$$\text{Length} = \frac{L}{2} + \pi \times R + 2 \times T + E$$

≈ 1 ft(m) chain = 8(25) links each 1.57 in (40 mm)

The fixed point of the cable drag chain should be connected in the middle of the travel distance. This arrangement gives the shortest connection between the fixed point and the moving point and thus the most efficient chain length.

Installation dimensions (in inch)

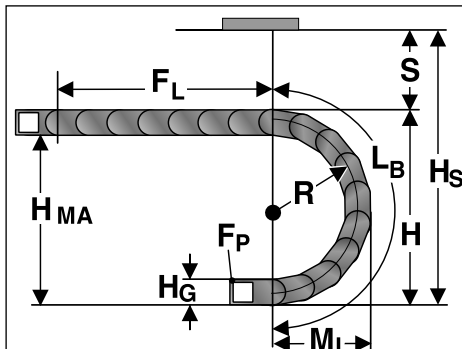

Radius R	3.15	3.94	4.92	5.91	7.87
Outside height of chain link (H_o)	1.89	1.89	1.89	1.89	1.89
Height of bend (H)	8.19	9.76	11.73	13.70	17.64
Height of moving end connection (H_{ma})	6.30	7.87	9.84	11.81	15.75
Safety margin (S)	1.26	1.26	1.26	1.26	1.26
Installation height (H_s)	9.45	11.02	12.99	14.96	18.90
Arc projection (M_L)	5.67	6.46	7.44	8.43	10.39
Bend length (L_b)	14.45	16.89	20.00	23.07	29.25



MP 36 G - SafeLine

Chain bracket

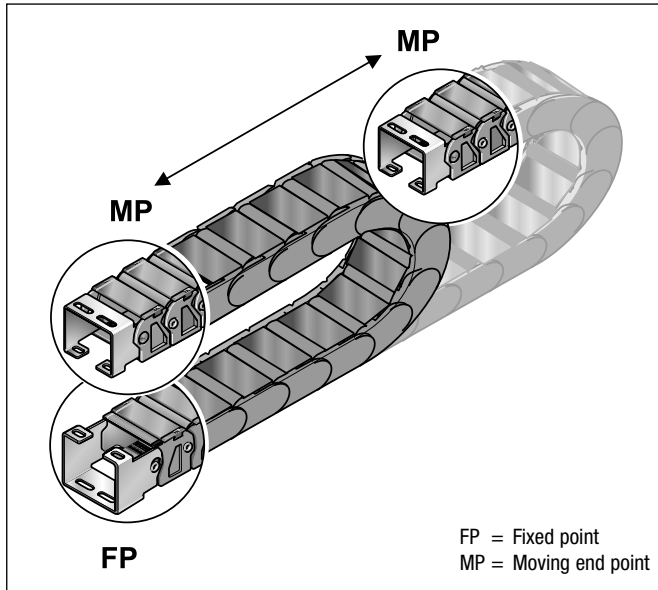

Chain bracket U-part

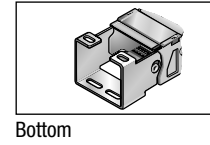
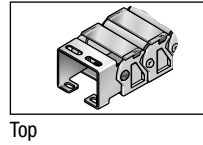

End brackets flange

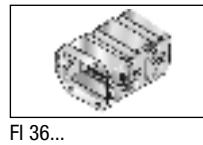

Chain bracket U-part

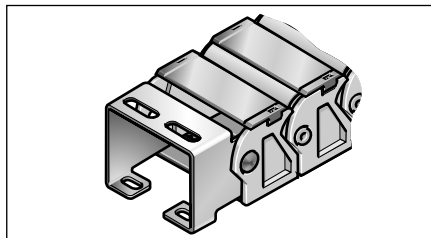

KA 36...

Type	Order no.	Material	Pack qty.
KA 36062 C Female end	036000001000	Sheet steel	1
KA 36062 C Male end	036000001100	Sheet steel	1
KA 36086 C Female end	036000001200	Sheet steel	1
KA 36086 C Male end	036000001300	Sheet steel	1
KA 36102 C Female end	036000001400	Sheet steel	1
KA 36102 C Male end	036000001500	Sheet steel	1
KA 36125 C Female end	036000001600	Sheet steel	1
KA 36125 C Male end	036000001700	Sheet steel	1
KA 36062 C Female end	036000002000	Stainless steel 1.4301	1
KA 36062 C Male end	036000002100	Stainless steel 1.4301	1
KA 36086 C Female end	036000002200	Stainless steel 1.4301	1
KA 36086 C Male end	036000002300	Stainless steel 1.4301	1
KA 36102 C Female end	036000002400	Stainless steel 1.4301	1
KA 36102 C Male end	036000002500	Stainless steel 1.4301	1
KA 36125 C Female end	036000002600	Stainless steel 1.4301	1
KA 36125 C Male end	036000002700	Stainless steel 1.4301	1

A cable drag chain requires two chain brackets. The U-shaped part connection offers two different fastening possibilities.

End brackets flange

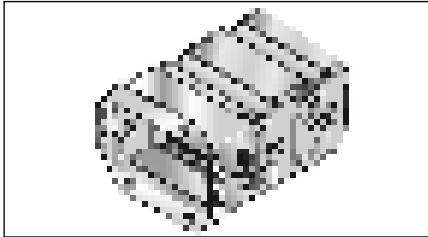

FL 36...

Type	Order no.	Material	Pack qty.
FL 36062	0360062054	Sheet steel	1
FL 36086	0360086054	Sheet steel	1
FL 36102	0360102054	Sheet steel	1
FL 36125	0360125054	Sheet steel	1
FL 36062	0360062056	Stainless steel 1.4301	1
FL 36086	0360086056	Stainless steel 1.4301	1
FL 36102	0360102056	Stainless steel 1.4301	1
FL 36125	0360125056	Stainless steel 1.4301	1

A cable drag chain requires two chain brackets. The divisible flange connection has been specifically designed for commissioning and re-installation. This keeps the chain in the installed position.

Chain bracket U-part

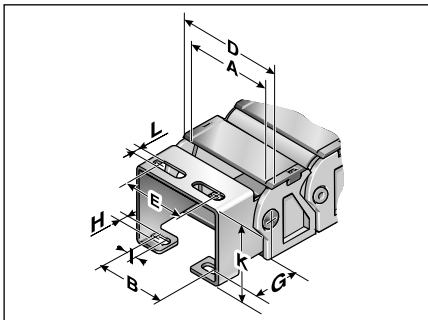

KA 36062-125

Type	A inch	B/E inch	D inch	G inch	H/L inch	I inch	K inch
KA 36062 Female end	2.44	2.15	3.19	1.65	0.26	0.24	1.92
KA 36062 Male end	2.44	2.15	3.19	1.65	0.26	0.24	1.92
KA 36086 Female end	3.39	3.09	4.13	1.65	0.26	0.61	1.92
KA 36086 Male end	3.39	3.09	4.13	1.65	0.26	0.61	1.92
KA 36102 Female end	4.02	3.72	4.76	1.65	0.26	0.61	1.92
KA 36102 Male end	4.02	3.72	4.76	1.65	0.26	0.61	1.92
KA 36125 Female end	4.92	4.63	5.67	1.65	0.26	0.61	1.92
KA 36125 Male end	4.92	4.63	5.67	1.65	0.26	0.61	1.92

End brackets flange

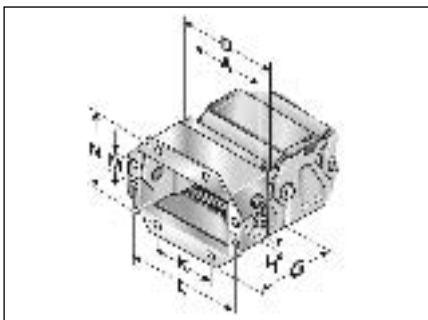

FL 36062-36125

Type	A inch	D inch	G inch	H Ø inch	K inch	L inch	M inch	N inch
FL 36062 Female end	2.44	3.19	2.03	0.28	1.57	3.85	0.71	2.70
FL 36062 Male end	2.44	3.19	2.38	0.28	1.57	3.85	0.71	2.70
FL 36086 Female end	3.39	4.13	2.03	0.28	2.52	4.80	0.71	2.70
FL 36086 Male end	3.39	4.13	2.38	0.28	2.52	4.80	0.71	2.70
FL 36102 Female end	4.02	4.76	2.03	0.28	3.15	5.43	0.71	2.70
FL 36102 Male end	4.02	4.76	2.38	0.28	3.15	5.43	0.71	2.70
FL 36125 Female end	4.92	5.67	2.03	0.28	4.06	6.33	0.71	2.70
FL 36125 Male end	4.92	5.67	2.38	0.28	4.06	6.33	0.71	2.70



Separator



Separator

Type	Order no.	Designation	Lock grid spacing inch	Pack qty.
TR 36G	036000009200	Separator	0.14	1

We recommend that separators be used if multiple round cables or conduits with differing diameters are to be installed. An offset configuration of the separators is advisable.

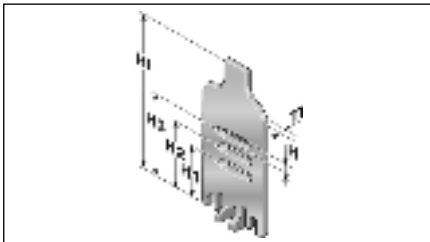

Separator

Type	T1 inch	H inch	H1 inch	H2 inch	H3 inch	H4 inch
TR 36G	0.10	0.10	0.53	0.77	1.00	1.44

Shelving system

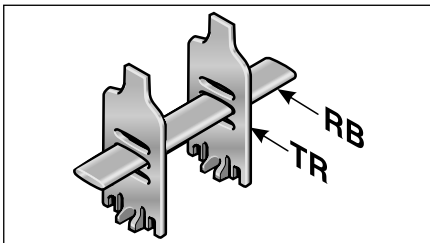

Shelving system

Type	Order no.	Designation	Width inch	Lock grid spacing inch	Pack qty.
RB 062	100000006200	RB 062 Shelf	2.44	0.10	1
RB 086	100000008600	RB 086 Shelf	3.39	0.10	1
RB 101	100000010100	RB 101 Shelf	3.98	0.10	1
RB 125	100000012500	RB 125 Shelf	4.92	0.10	1

The shelf must be used with a minimum of two separators to create a shelving system. The additional levels prevent cables from criss-crossing and therefore destroying each other, while also avoiding excessive friction. The shelves are matched to the available chain widths.

Assembly

Disassembly

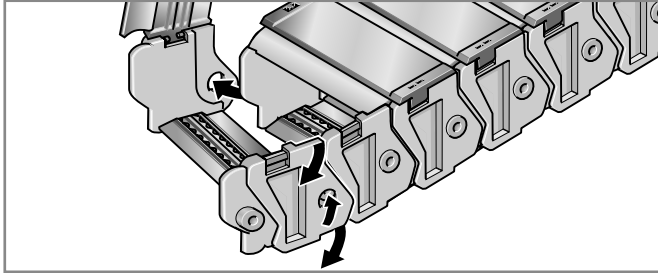

Step 1

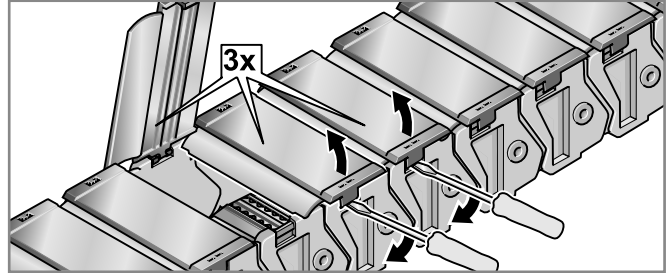

Step 1

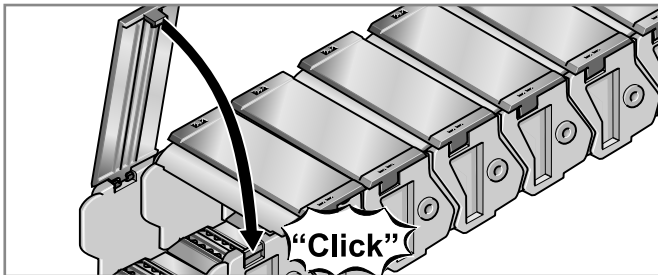

Step 2

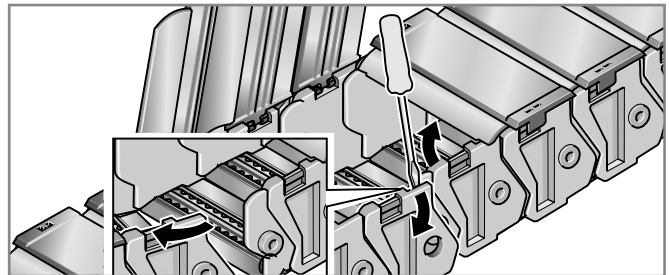

Step 2

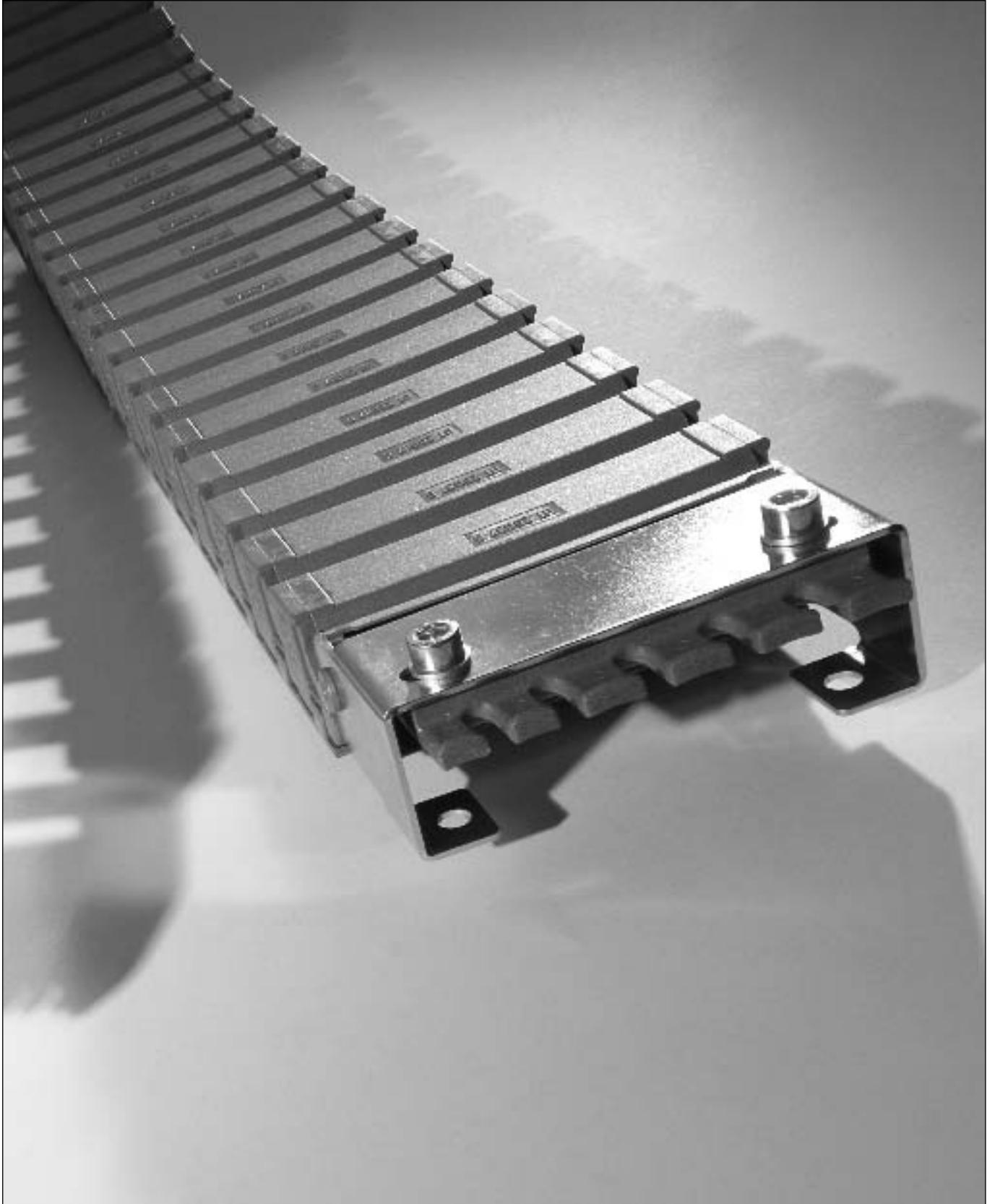

Cable drag chain systems

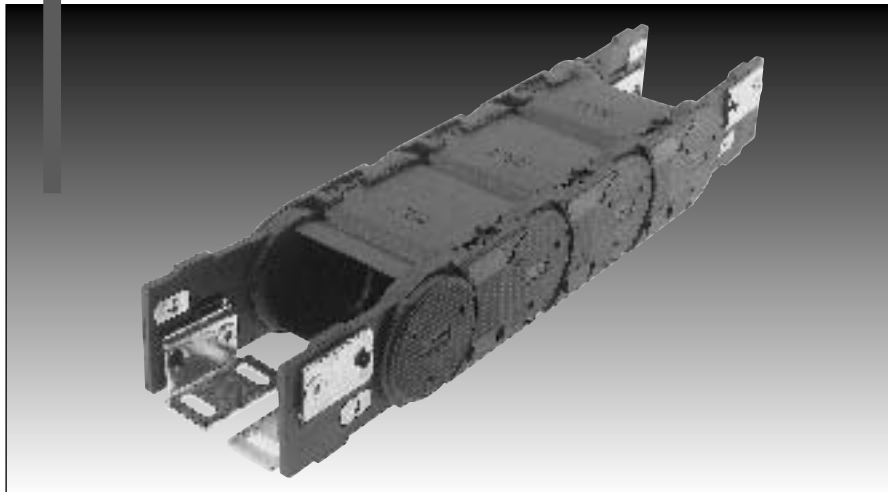

MultiLine

MP 43 G



MP 43 G - MultiLine

Order variants

Style (order code)							
Configuration (order code)							
Radius (order code)		The radii can be combined with any internal width					
in inch							
Internal width (order code)							
in inch							
Outside width (order code)							
in inch							
MP43 062	3.74	2.44	062				
MP43 084	4.61	3.31	084	4.92	125		
MP43 105	5.43	4.13	105	5.91	150	0	
MP43 144	6.97	5.67	144	7.87	200	1	0
MP43 182	8.46	7.17	182	9.84	250	9	9

Order-Number:	<input type="text" value="0430"/>	<input type="text"/>	<input type="text" value="0"/>	<input type="text"/>	<input type="text" value="0"/>
----------------------	-----------------------------------	----------------------	--------------------------------	----------------------	--------------------------------

Configuration:

- 0 PA crossbar every link; w/bias
- 1 PA crossbar every link; w/o bias
- 9 Custom version

Style:

- 0 Standard (PA/black)
- 9 Custom version

Sample order:

0430 062 125 0000

Internal width = 2.44 in (62 mm)
 Radius = 4.92 in (125 mm)
 Configuration = 0
 Style = 0

Ideal operating conditions:





- Compact dimensions with opening cover in inside/outside bend
- Quiet operation
- High stability
- Flexible internal separation

Alternative chain type:

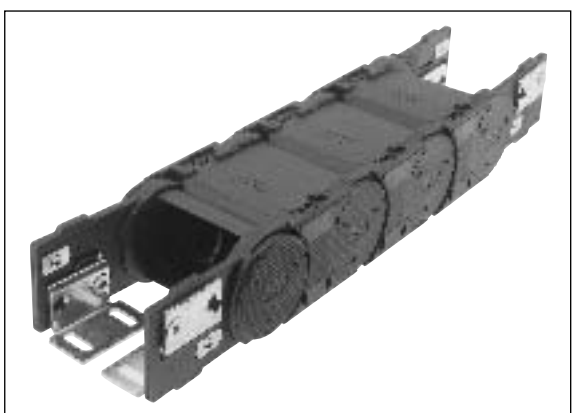
- MP 44 open version
- MP 36 G/MP 65 G
Flange connection

Features



-  Chain bracket with variably positionable metal angle
-  Radii with or without bias (RV/RK)
-  Strain relief plate ZL
-  Crossbar/cover can be removed from inside and outside flexure curve
-  Plug-in shelf system for reliable cable guidance

Technical data

Chain link dimensions (inch) (mm)

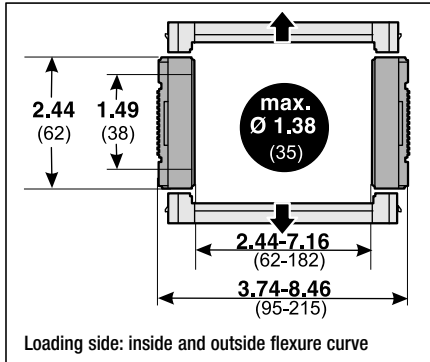

Material characteristics standard (PA/black)

Operating temperature: -22 to 248° F
 Gliding friction factor: 0.30
 Static friction factor: 0.45
 Fire classification: Based on UL94 HB

Other material properties on request

Technical specifications

Travel distance, gliding, L_g : 164.04 ft
 Travel distance, self-supporting, L_s : see diagram
 Travel distance, vertical, hanging, L_{vh} : 131.23 ft
 Travel distance, vertical, upright, L_{vu} : 9.84 ft
 Rotated 90°, self-supporting, L_{90r} : 3.28 ft
 Speed, gliding, V_g : 16.40 ft/s
 Speed, self-supporting, V_s : 49.21 ft/s
 Acceleration, gliding, a_g : 49.21 ft/s²
 Acceleration, self-supporting, a_s : 65.62 ft/s²

Self-supporting length

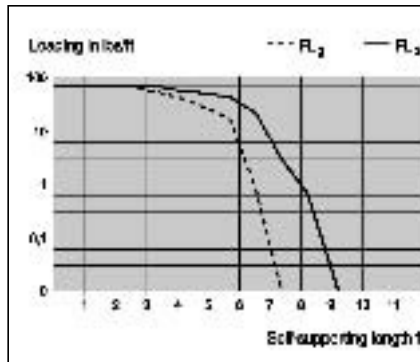
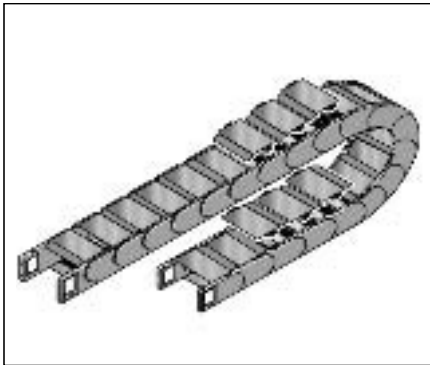

FL₂:
 Ideal installation situation for high stresses at the limit of the max. travel parameters. In this range the chain upper run is still biased, straight or has a max. sag of 0.39 – 1.97 in (10 – 50 mm) depending on the type of chain.

FL₃:
 Satisfactory installation position for many applications working in the lower to middle range of the max. travel parameters. Depending on the chain type, the sag of the chain upper run is >0.39 – 1.97 in (>10 – 50 mm) but certainly less than the max. sag.

If the sag is greater than FL₃, the arrangement is unsuitable and should be avoided. Please choose a more stable Murrplastik cable drag chain.

Determining the chain length

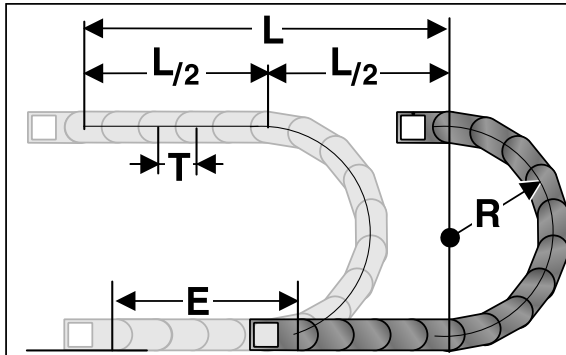

L = Travel distance
 R = Radius
 T = Pitch
 E = Distance between entry point and middle of travel distance

Determining the chain length

$$\text{Length} = \frac{L}{2} + \pi \times R + E$$

≈ 1 ft(m) chain = 4(13) links each 2.97 in (75.5 mm)

The fixed point of the cable drag chain should be connected in the middle of the travel distance. This arrangement gives the shortest connection between the fixed point and the moving point and thus the most efficient chain length.

Installation dimensions (in inch)

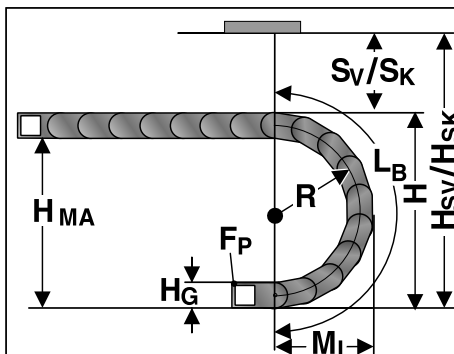

Radius R	4.92	5.91	7.87	9.84
Outside height of chain link (H _o)	2.44	2.44	2.44	2.44
Height of bend (H)	12.28	14.25	18.19	22.13
Height of moving end connection (H _{MA})	9.84	11.81	15.75	7.87
Safety margin with bias (S _v)	1.50	1.50	1.50	1.50
Installation height with bias (H _{sv})	13.78	15.75	7.87	23.62
Safety margin without bias (S _k)	0.51	0.51	0.51	0.51
Installation height without bias (H _{sk})	12.80	14.76	18.70	22.64
Arc projection (M _l)	9.13	10.08	12.05	14.02
Bend length (L _b)	22.24	25.35	31.54	37.72



Chain bracket

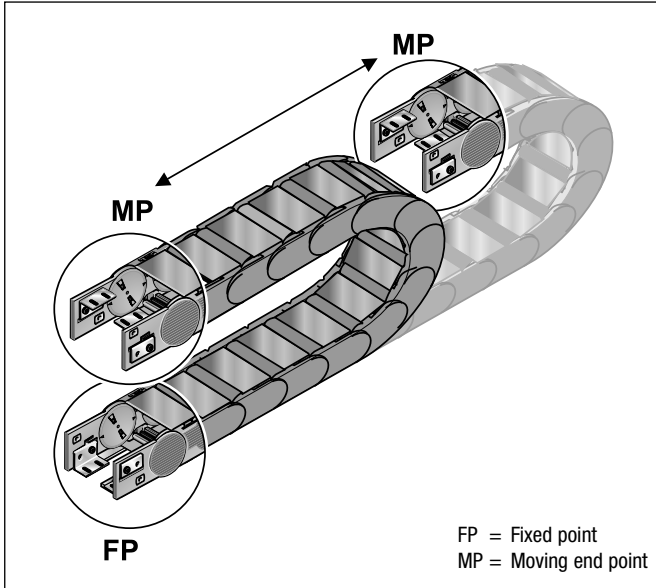

Chain bracket

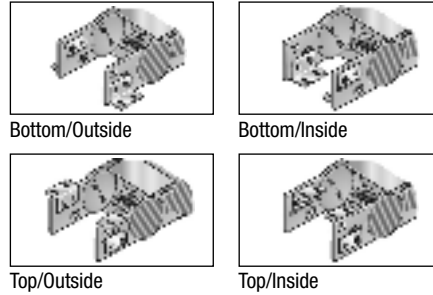

Chain bracket

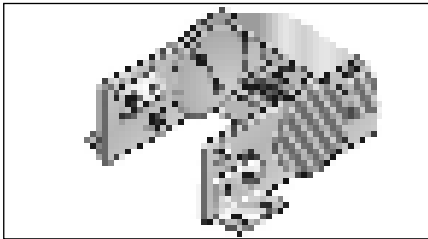

KA 44

Type	Order no.	Material	Pack qty.
KA 44	0440000050	Sheet steel	1
KA 44	0440000052	Stainless steel 1.4301	1

There are several options regarding the chain bracket. The fixed-point bracket (inside/bottom) and the moving end bracket (inside/top) are supplied as standard. However, any other combination can be supplied upon request. The chain bracket is fastened at the end like a side link. This enables the chain to move right up to the bracket. Each chain requires two chain brackets. The brackets should be fastened with M6 screws.

Chain bracket

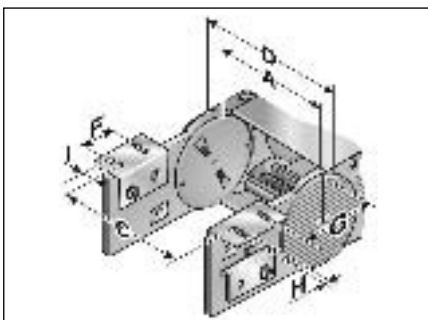

Bottom and top/outside

Type	A inch	C inch	D inch	F inch	G inch	H Ø inch	I inch
KA 44	2.44	3.96	3.78	1.26	1.70	0.26	0.49
KA 44	3.31	4.82	4.65	1.26	1.70	0.26	0.49
KA 44	4.13	5.65	5.47	1.26	1.70	0.26	0.49
KA 44	5.67	7.19	6.97	1.26	1.70	0.26	0.49
KA 44	7.17	8.68	8.46	1.26	1.70	0.26	0.49

Chain bracket

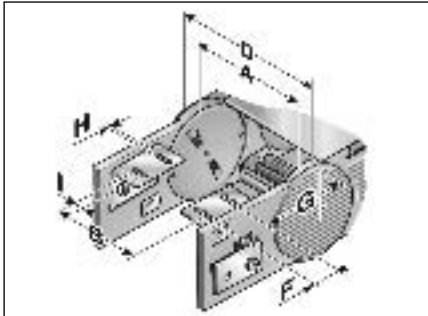

Bottom and top/inside

Type	A inch	B inch	D inch	F inch	G inch	H Ø inch	I inch
KA 44	2.44	1.87	3.78	1.26	1.70	0.26	0.49
KA 44	3.31	2.74	4.65	1.26	1.70	0.26	0.49
KA 44	4.13	3.56	5.47	1.26	1.70	0.26	0.49
KA 44	5.67	5.10	6.97	1.26	1.70	0.26	0.49
KA 44	7.17	6.59	8.46	1.26	1.70	0.26	0.49

Separator



Separator

Type	Order no.	Designation	Lock grid spacing inch	Pack qty.
TF 43	0430000090	Separator	0.06	1

We recommend that moveable separators are used if multiple round cables or conduits with differing diameters are to be installed. An offset configuration of the separators is advisable. When the frame bridge is opened, the separator is guaranteed to remain solidly mounted on one side.



Separator

Type	T1 inch	H inch	H1 inch	H2 inch	H3 inch	H4 inch
TF 43	0.16	0.17	0.48	0.77	1.04	1.50

Shelving system

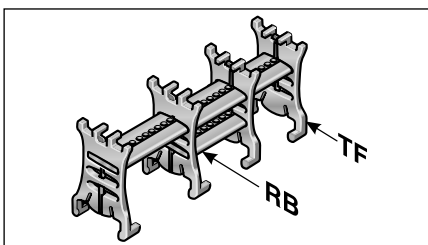

Shelving system

Type	Order no.	Designation	Width inch	Lock grid spacing inch	Pack qty.
RB 031	100000003100	RB 031 Shelf	1.22	0.06	1
RB 048	100000004800	RB 048 Shelf	1.89	0.06	1
RB 070	100000007000	RB 070 Shelf	2.76	0.06	1
RB 092	100000009200	RB 092 Shelf	3.62	0.06	1
RB 128	100000012800	RB 128 Shelf	5.04	0.06	1
RB 167	100000016700	RB 167 Shelf	6.57	0.06	1

The shelf must be used with a minimum of two separators to create a shelving system. The additional levels prevent cables from criss-crossing and therefore destroying each other, while also avoiding excessive friction. The shelves are matched to the available chain widths.



MP 43 G - Accessories

Assembly Disassembly

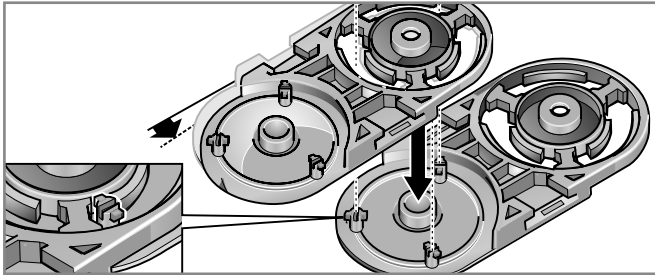

Step 1

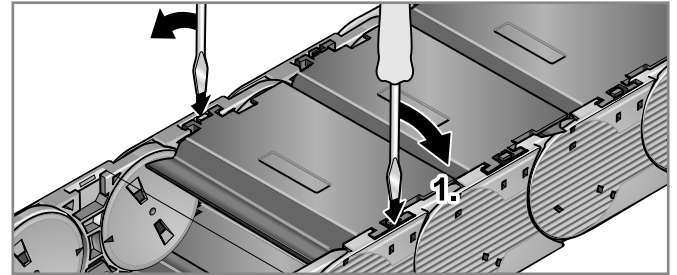

Step 1

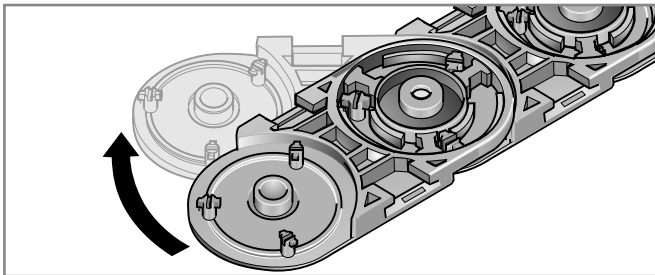

Step 2

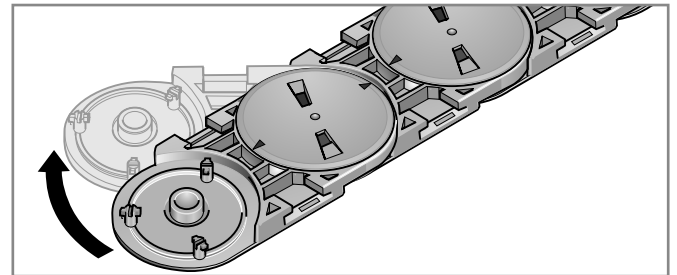

Step 2

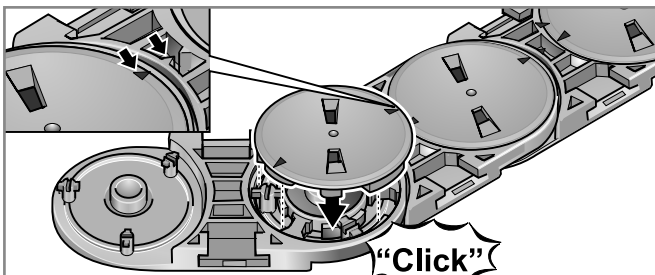

Step 3

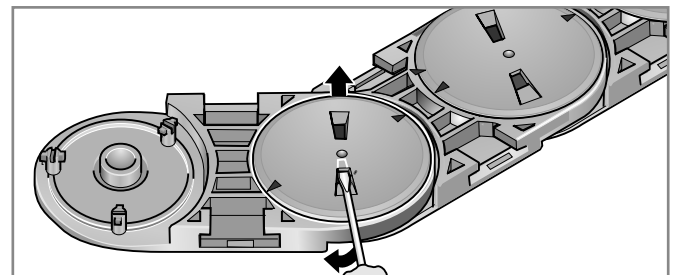

Step 3

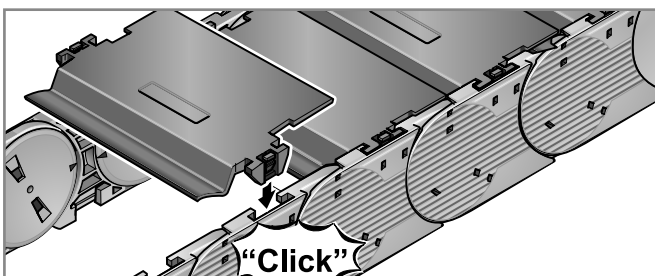

Step 4

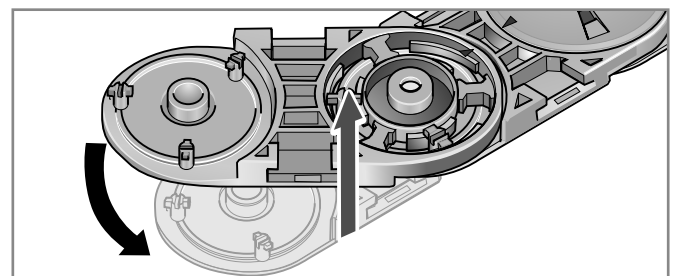

Step 4

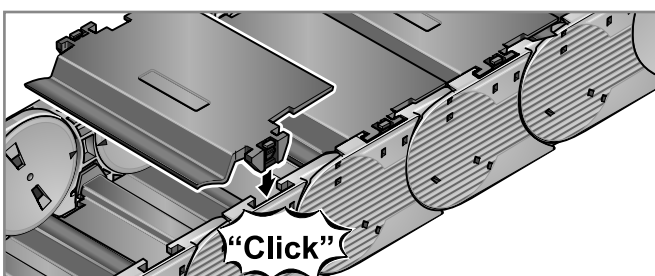

Step 5

Cable drag chain systems

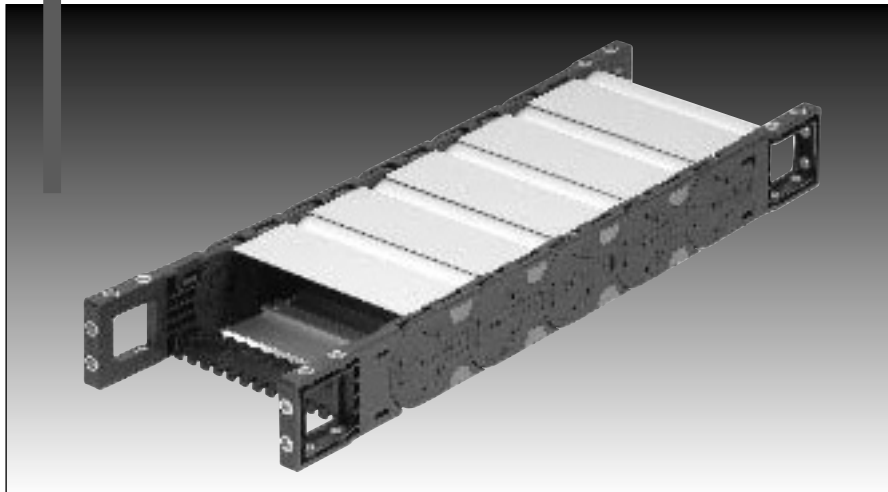

ClosedLine

MP 41.3 G



MP 41.3 G - ClosedLine

Order variants

Style (order code)						
Configuration (order code) * = standard						
Radius (order code) <small>The radii can be combined with any internal width</small>						
in mm						
Internal width (order code) <small># also available with plastic cover</small>						
in mm						
Outside width in mm						
MP41.3G 071	4.06	2.80	071			
MP41.3G 084	4.57	3.31	084#			
MP41.3G 096	5.04	3.78	096#			
MP41.3G 107	5.47	4.21	107			
MP41.3G 121	6.02	4.76	121#			
MP41.3G 133	6.50	5.24	133			
MP41.3G 144	6.93	5.67	144			
MP41.3G 146	7.01	5.75	146#			
MP41.3G 158	7.48	6.22	158			
MP41.3G 171	7.99	6.73	171			
MP41.3G 182	8.43	7.17	182			
MP41.3G 196	8.98	7.72	196#			
MP41.3G 220	9.92	8.66	220			
MP41.3G 246	10.94	9.69	246#			
MP41.3G 296	12.91	11.65	296#	5.91	150	0
MP41.3G 346	14.88	13.62	346	7.87	200	1
MP41.3G xxx	inside + 1.26	>3.78	Alu	9.84	250	4*
		-23.62		11.81	300	5*
						0
						9

Order-Number:

Configuration:

- 0 PA crossbar every link; w/bias
- 1 PA crossbar every link; w/o bias
- 4* AL crossbar every link; w/bias
- 5* AL crossbar every link; w/o bias

Style:

- 0 Standard (PA/black)
- 9 Custom version

Sample order:

0413 071 150 0000

Internal width = 2.80 in (71 mm)
 Radius = 5.91 in (150 mm)
 Configuration = 0
 Style = 0

Ideal operating conditions:

- Extremely high accelerations
- Extremely high speeds
- Very high additional loads
- Long travel distances
- Extreme self-supporting lengths

Alternative chain type:

- MP 41.2 open series
- MP 43G for easier use

Note:

- Plastic cover available from 1st Quarter 2008

Features

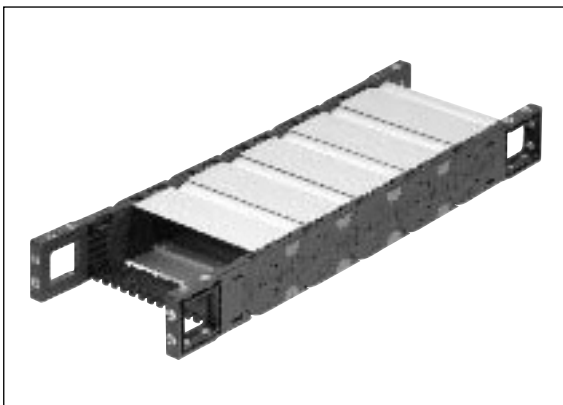

- Chain bracket, can be fastened on three sides
- Chain bracket with variably positionable metal angle
- Crossbar/cover can be removed from inside and outside flexure curve
- Side links with CLICK lock for easy opening
- Radii with or without bias (RV/RK)
- Crossbar strain relief can be integrated into chain bracket
- Aluminum frame bridges with integrated lock grid in variable lengths
- C-profile rail can be integrated into chain bracket
- Integrable separator for cable separation
- Foldable shelf system for reliable cable guidance

Technical data

Chain link dimensions (inch) (mm)

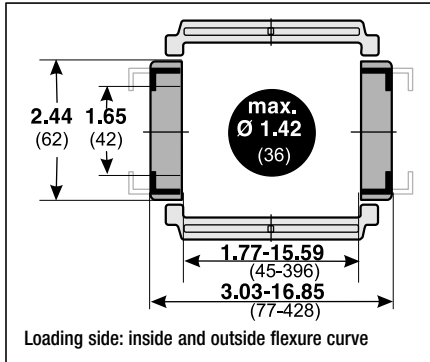

Material characteristics standard (PA/black)

Operating temperature: -22 to 248° F
 Gliding friction factor: 0.30
 Static friction factor: 0.45
 Fire classification: Based on UL94 HB

Other material properties on request

Technical specifications

Travel distance, gliding, L_g : 393.70 ft
 Travel distance, self-supporting, L_s : see diagram
 Travel distance, vertical, hanging, L_{vh} : 328.08 ft
 Travel distance, vertical, upright, L_{vu} : 19.69 ft
 Rotated 90°, self-supporting, L_{90r} : 3.28 ft
 Speed, gliding, V_g : 16.40 ft/s
 Speed, self-supporting, V_s : 65.62 ft/s
 Acceleration, gliding, a_g : 82.02 ft/s²
 Acceleration, self-supporting, a_s : 98.43 ft/s²

Self-supporting length

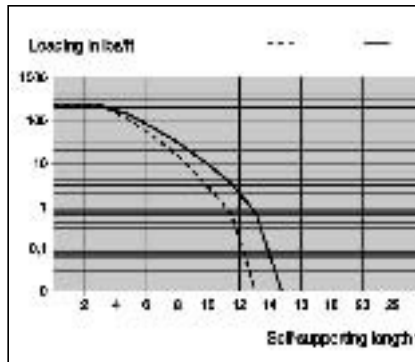
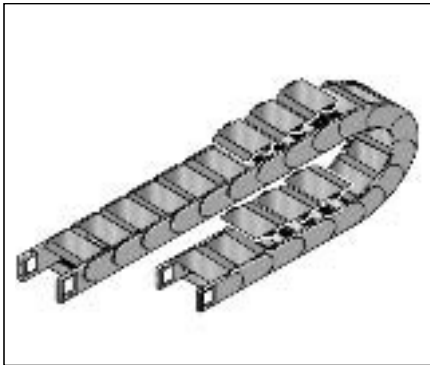

FL_g:

Ideal installation situation for high stresses at the limit of the max. travel parameters. In this range the chain upper run is still biased, straight or has a max. sag of 0.39 – 1.97 in (10 – 50 mm) depending on the type of chain.

FL_b:

Satisfactory installation position for many applications working in the lower to middle range of the max. travel parameters. Depending on the chain type, the sag of the chain upper run is >0.39 – 1.97 in (>10 – 50 mm) but certainly less than the max. sag.

If the sag is greater than FL_b, the arrangement is unsuitable and should be avoided. Please choose a more stable Murrplastik cable drag chain.

Determining the chain length

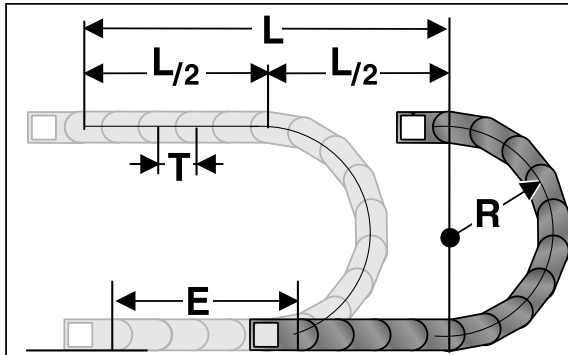

L = Travel distance
 R = Radius
 T = Pitch
 E = Distance between entry point and middle of travel distance

Determining the chain length

$$\text{Length} = \frac{L}{2} + \pi \times R + E$$

≈ 1 ft(m) chain = 4(13) links each 3.03 in (77 mm)

The fixed point of the cable drag chain should be connected in the middle of the travel distance. This arrangement gives the shortest connection between the fixed point and the moving point and thus the most efficient chain length.

Installation dimensions (in inch)

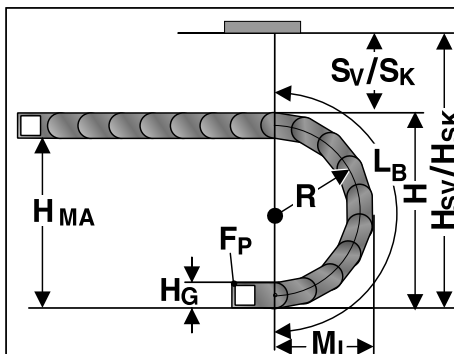

Radius R	5.91	7.87	9.84	11.81
Outside height of chain link (H_o)	2.44	2.44	2.44	2.44
Height of bend (H)	14.65	18.58	22.52	26.46
Height of moving end connection (H_{ma})	12.20	16.14	20.08	24.02
Safety margin with bias (S_v)	1.81	1.81	1.81	1.81
Installation height with bias (H_{sv})	16.46	20.39	24.33	28.27
Safety margin without bias (S_k)	0.63	0.63	0.63	0.63
Installation height without bias (H_{sk})	15.28	19.21	23.15	27.09
Arc projection (M_l)	10.35	12.32	14.29	16.26
Bend length (L_b)	26.02	32.20	38.39	44.57



MP 41.3 G - ClosedLine

Chain bracket

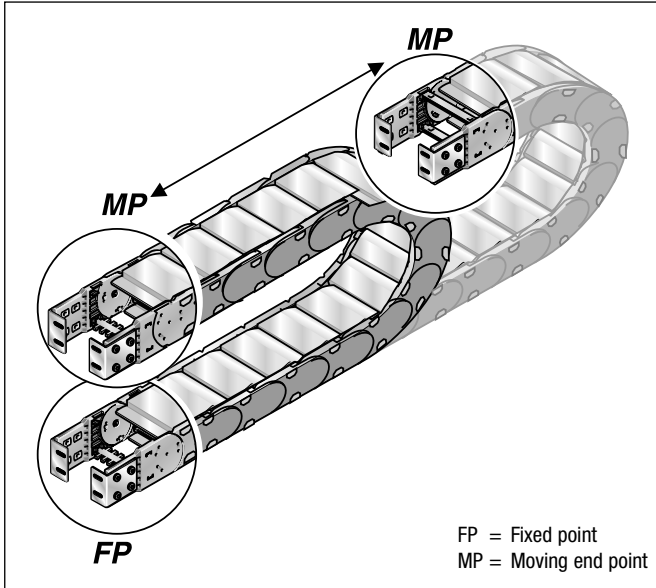

Flexible chain bracket

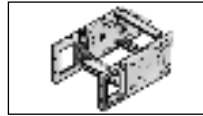

Chain bracket angle

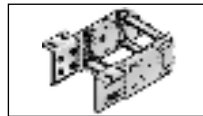

Top/Outside

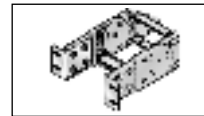

Front/Outside

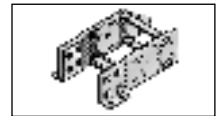

Bottom/Outside

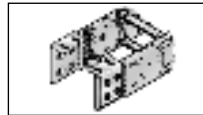

Top/Inside

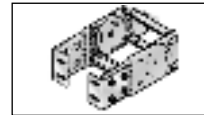

Front/Inside

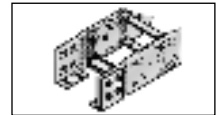

Bottom/Inside

Flexible chain bracket

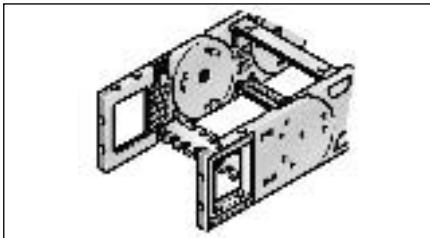

Type	Order no.	Version	Pack qty.
KA 41-FB	0411000054	with bushing	1
KA 41-FG	0411000055	with thread	1

This chain bracket offers universal connection options (top, bottom and front) and is attached to the ends of the chain like a side link. This allows the chain to move right up to the bracket. Each chain requires one male and one female bracket. M6 screws are used to secure the brackets in place. Extrusion-coated metal bushings with either a through-hole (-FB) or a threaded hole (-FG) ensure the permanent, high-strength transmission of even extreme forces onto the cable drag chain.

Chain bracket angle

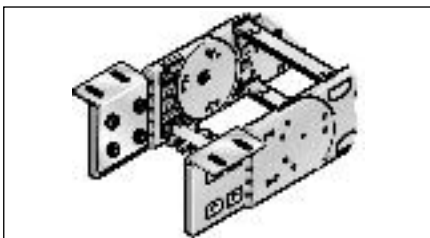

Type	Order no.	Pack qty.
KA 41	0410000051	1

There are several options regarding the chain bracket. The fixed-point bracket (inside/bottom) and the moving end bracket (inside/top) are supplied as standard. However, any other combination can be supplied upon request. The chain bracket is fastened at the end like a side link. This enables the chain to move right up to the bracket. Each chain requires one male and one female bracket. The brackets should be fastened with M6 screws.

Flexible chain bracket

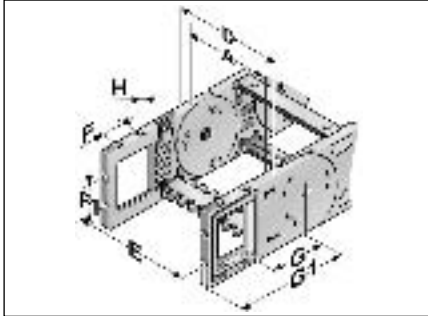

Flexible with through-hole

Type	A inch	D inch	E inch	F inch	F1 inch	G inch	G1 inch	H Ø inch
KA41-FB	2.80	4.13	3.58	0.89	0.87	3.11	4.72	0.26
KA41-FB	3.31	4.65	4.09	0.89	0.87	3.11	4.72	0.26
KA41-FB	3.78	5.12	4.57	0.89	0.87	3.11	4.72	0.26
KA41-FB	4.21	5.55	5.00	0.89	0.87	3.11	4.72	0.26
KA41-FB	4.76	6.10	5.55	0.89	0.87	3.11	4.72	0.26
KA41-FB	5.24	6.57	6.46	0.89	0.87	3.11	4.72	0.26
KA41-FB	5.67	7.01	6.46	0.89	0.87	3.11	4.72	0.26
KA41-FB	5.75	7.09	6.54	0.89	0.87	3.11	4.72	0.26
KA41-FB	6.22	7.56	7.01	0.89	0.87	3.11	4.72	0.26
KA41-FB	6.73	8.07	7.52	0.89	0.87	3.11	4.72	0.26
KA41-FB	7.17	8.90	7.95	0.89	0.87	3.11	4.72	0.26
KA41-FB	7.72	9.06	8.50	0.89	0.87	3.11	4.72	0.26
KA41-FB	8.66	10.00	9.45	0.89	0.87	3.11	4.72	0.26
KA41-FB	9.69	11.02	10.47	0.89	0.87	3.11	4.72	0.26
KA41-FB	11.65	12.99	12.44	0.89	0.87	3.11	4.72	0.26
KA41-FB	13.62	14.96	14.41	0.89	0.87	3.11	4.72	0.26
KA41-FB	variable	A+1.34	A+0.79	0.89	0.87	3.11	4.72	0.26

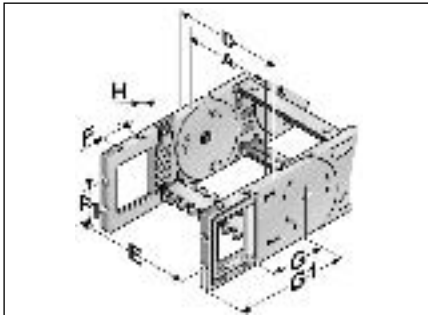

Flexible with threaded bushing

Type	A inch	D inch	E inch	F inch	F1 inch	G inch	G1 inch	H
KA41-FG	2.80	4.13	3.58	0.89	0.87	3.11	4.72	M6
KA41-FG	3.31	4.65	4.09	0.89	0.87	3.11	4.72	M6
KA41-FG	3.78	5.12	4.57	0.89	0.87	3.11	4.72	M6
KA41-FG	4.21	5.55	5.00	0.89	0.87	3.11	4.72	M6
KA41-FG	4.76	6.10	5.55	0.89	0.87	3.11	4.72	M6
KA41-FG	5.24	6.57	6.46	0.89	0.87	3.11	4.72	M6
KA41-FG	5.67	7.01	6.46	0.89	0.87	3.11	4.72	M6
KA41-FG	5.75	7.09	6.54	0.89	0.87	3.11	4.72	M6
KA41-FG	6.22	7.56	7.01	0.89	0.87	3.11	4.72	M6
KA41-FG	6.73	8.07	7.52	0.89	0.87	3.11	4.72	M6
KA41-FG	7.17	8.90	7.95	0.89	0.87	3.11	4.72	M6
KA41-FG	7.72	9.06	8.50	0.89	0.87	3.11	4.72	M6
KA41-FG	8.66	10.00	9.45	0.89	0.87	3.11	4.72	M6
KA41-FG	9.69	11.02	10.47	0.89	0.87	3.11	4.72	M6
KA41-FB	11.65	12.99	12.44	0.89	0.87	3.11	4.72	M6
KA41-FB	13.62	14.96	14.41	0.89	0.87	3.11	4.72	M6
KA41-FB	variable	A+1.34	A+0.79	0.89	0.87	3.11	4.72	M6



MP 41.3 G - ClosedLine

Chain bracket angle

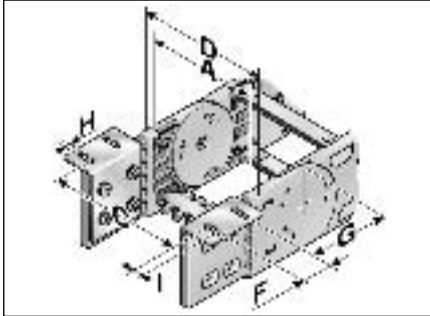

Bottom and top/outside

Type	A inch	C inch	D inch	F inch	G inch	H Ø inch	I inch
KA 41	2.80	4.15	4.06	1.26	3.11	0.26	0.55
KA 41	3.31	4.67	4.57	1.26	3.11	0.26	0.55
KA 41	3.78	5.14	5.04	1.26	3.11	0.26	0.55
KA 41	4.21	5.57	5.47	1.26	3.11	0.26	0.55
KA 41	4.76	6.12	6.02	1.26	3.11	0.26	0.55
KA 41	5.24	6.59	6.5	1.26	3.11	0.26	0.55
KA 41	5.67	7.03	6.93	1.26	3.11	0.26	0.55
KA 41	5.75	7.11	7.01	1.26	3.11	0.26	0.55
KA 41	6.22	7.58	7.48	1.26	3.11	0.26	0.55
KA 41	6.73	8.09	7.99	1.26	3.11	0.26	0.55
KA 41	7.17	8.50	8.27	1.26	3.11	0.26	0.55
KA 41	7.72	9.07	8.98	1.26	3.11	0.26	0.55
KA 41	8.66	10.02	9.92	1.26	3.11	0.26	0.55
KA 41	9.69	11.04	10.94	1.26	3.11	0.26	0.55
KA 41	11.65	13.01	12.91	1.26	3.11	0.26	0.55
KA 41	13.62	14.98	14.88	1.26	3.11	0.26	0.55
KA 41	variable	A+1.36	A+1.26	1.26	3.11	0.26	0.55

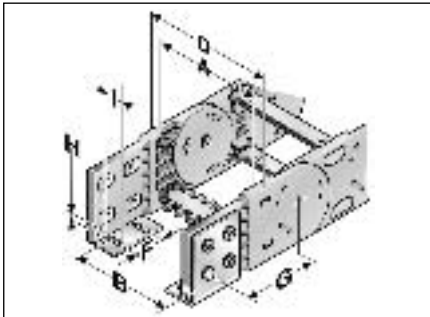

Bottom and top/inside

Type	A inch	C inch	D inch	F inch	G inch	H Ø inch	I inch
KA 41	2.80	2.70	4.06	1.26	3.11	0.26	0.55
KA 41	3.31	3.21	4.57	1.26	3.11	0.26	0.55
KA 41	3.78	3.68	5.04	1.26	3.11	0.26	0.55
KA 41	4.21	4.11	5.47	1.26	3.11	0.26	0.55
KA 41	4.76	4.67	6.02	1.26	3.11	0.26	0.55
KA 41	5.24	5.18	6.5	1.26	3.11	0.26	0.55
KA 41	5.67	5.57	6.93	1.26	3.11	0.26	0.55
KA 41	5.75	5.65	7.01	1.26	3.11	0.26	0.55
KA 41	6.22	6.12	7.48	1.26	3.11	0.26	0.55
KA 41	6.73	6.63	7.99	1.26	3.11	0.26	0.55
KA 41	7.17	7.07	8.27	1.26	3.11	0.26	0.55
KA 41	7.72	7.62	8.98	1.26	3.11	0.26	0.55
KA 41	8.66	8.56	9.92	1.26	3.11	0.26	0.55
KA 41	9.69	9.59	10.94	1.26	3.11	0.26	0.55
KA 41	11.65	11.56	12.91	1.26	3.11	0.26	0.55
KA 41	13.62	13.52	14.88	1.26	3.11	0.26	0.55
KA 41	variable	A-0.10	A+1.26	1.26	3.11	0.26	0.55

Chain bracket angle

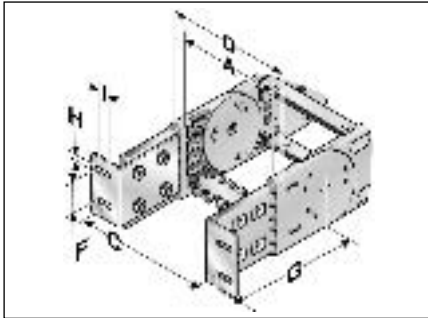

Front/Outside

Type	A inch	C inch	D inch	F inch	G inch	H Ø inch	I inch
KA 41	2.80	4.15	4.06	1.26	4.95	0.26	0.55
KA 41	3.31	4.67	4.57	1.26	4.95	0.26	0.55
KA 41	3.78	5.14	5.04	1.26	4.95	0.26	0.55
KA 41	4.21	5.57	5.47	1.26	4.95	0.26	0.55
KA 41	4.76	6.12	6.02	1.26	4.95	0.26	0.55
KA 41	5.24	6.59	6.5	1.26	4.95	0.26	0.55
KA 41	5.67	7.03	6.93	1.26	4.95	0.26	0.55
KA 41	5.75	7.11	7.01	1.26	4.95	0.26	0.55
KA 41	6.22	7.58	7.48	1.26	4.95	0.26	0.55
KA 41	6.73	8.09	7.99	1.26	4.95	0.26	0.55
KA 41	7.17	8.50	8.27	1.26	4.95	0.26	0.55
KA 41	7.72	9.07	8.98	1.26	4.95	0.26	0.55
KA 41	8.66	10.02	9.92	1.26	4.95	0.26	0.55
KA 41	9.69	11.04	10.94	1.26	4.95	0.26	0.55
KA 41	11.65	13.01	12.91	1.26	4.95	0.26	0.55
KA 41	13.62	14.98	14.88	1.26	4.95	0.26	0.55
KA 41	variable	A+1.36	A+1.26	1.26	4.95	0.26	0.55

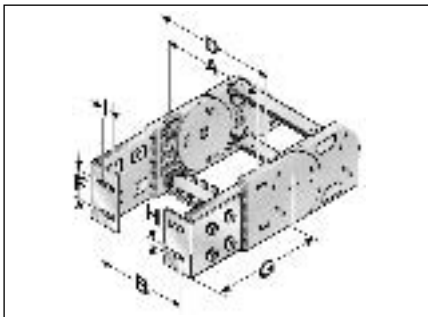

Front/Inside

Type	A inch	C inch	D inch	F inch	G inch	H Ø inch	I inch
KA 41	2.80	2.70	4.06	1.26	4.95	0.26	0.55
KA 41	3.31	3.21	4.57	1.26	4.95	0.26	0.55
KA 41	3.78	3.68	5.04	1.26	4.95	0.26	0.55
KA 41	4.21	4.11	5.47	1.26	4.95	0.26	0.55
KA 41	4.76	4.67	6.02	1.26	4.95	0.26	0.55
KA 41	5.24	5.18	6.5	1.26	4.95	0.26	0.55
KA 41	5.67	5.57	6.93	1.26	4.95	0.26	0.55
KA 41	5.75	5.65	7.01	1.26	4.95	0.26	0.55
KA 41	6.22	6.12	7.48	1.26	4.95	0.26	0.55
KA 41	6.73	6.63	7.99	1.26	4.95	0.26	0.55
KA 41	7.17	7.07	8.27	1.26	4.95	0.26	0.55
KA 41	7.72	7.62	8.98	1.26	4.95	0.26	0.55
KA 41	8.66	8.56	9.92	1.26	4.95	0.26	0.55
KA 41	9.69	9.59	10.94	1.26	4.95	0.26	0.55
KA 41	11.65	11.56	12.91	1.26	4.95	0.26	0.55
KA 41	13.62	13.52	14.88	1.26	4.95	0.26	0.55
KA 41	variable	A-0.10	A+1.26	1.26	4.95	0.26	0.55



MP 41.3 G - Accessories

Separator

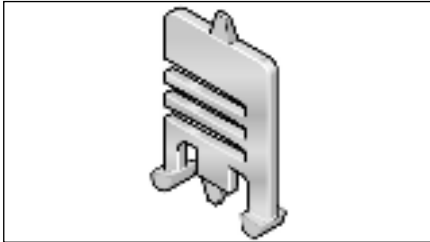

Separator

Type	Order no.	Designation	Lock grid spacing inch	Pack qty.
TR 41.1	041200009200	TR 41.1 Separator	0.22	1

We recommend that separators be used if multiple round cables or conduits with differing diameters are to be installed. An offset configuration of the separators is advisable.

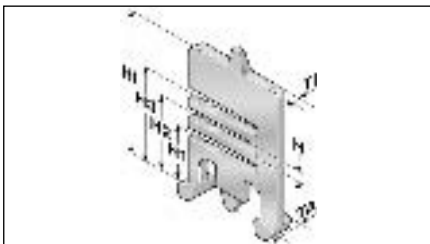

Separator

Type	T1 inch	H inch	H1 inch	H2 inch	H3 inch	HI inch
TR 41.1	0.14	0.16	0.71	0.98	1.22	1.65

Shelving system

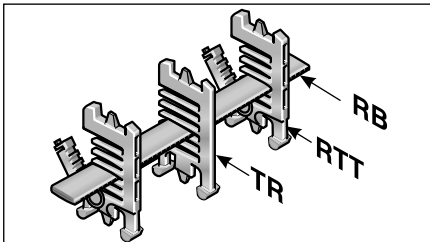

Shelving system

Type	Order no.	Designation	Width inch	Lock grid spacing inch	Pack qty.
RB 028-5	100000002800	RB 028-5 Shelf	1.10	0.22	1
RB 056-5	100000005600	RB 056-5 Shelf	2.20	0.22	1
RB 084-5	100000008400	RB 084-5 Shelf	3.31	0.22	1
RB 112-5	100000011200	RB 112-5 Shelf	4.41	0.22	1
RB 140-5	100000014000	RB 140-5 Shelf	5.51	0.22	1
RB 168-5	100000016800	RB 168-5 Shelf	6.61	0.22	1
RB 196-5	100000019600	RB 196-5 Shelf	7.72	0.22	1
RTT 41	100090412000	RTT 41 Shelf support, divisible		0.22	1

In connection with at least two shelf supports (RTT) the shelf becomes a shelving system. The additional levels prevent cables from criss-crossing and therefore destroying each other, while also avoiding excessive friction. Pre-assembly is not necessary as the shelving system and cabling can be assembled quickly and easily on site.

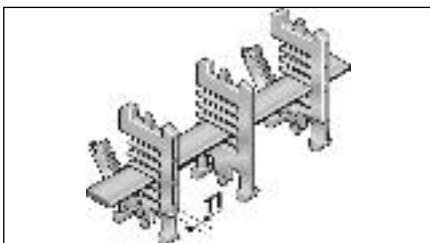

Shelving system

Type	T1 inch
RTT 41	0.28

Chain bracket cover D4

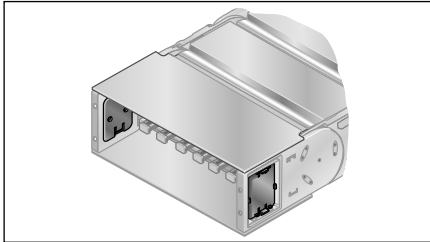

Side link cover

Type	Order no.	Pack qty.
Cover D4 KA 41.1-FB/FG	0413888002	2

Self-locking covers close the side mounting window on the flexible chain bracket (KA-FB/FG).

Chain bracket cover

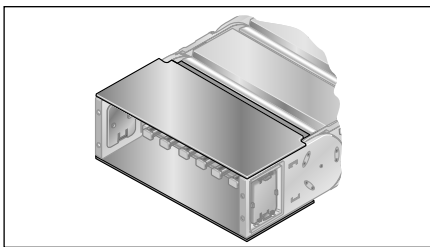

Covers for the flexible chain bracket (KA-FB/FG) allow for a closed variant up to the chain's end.

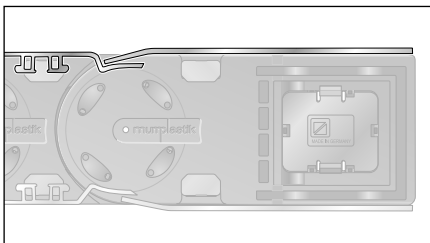

outside flexure curve

Type	Order no.	Inside width inch	Material	Pack qty.
Cover KA 41.1 FB/FG AB 062 1-2	0411062059	2.44	Anodized aluminum	1
Cover KA 41.1 FB/FG AB 071 1-2	0411062059	2.80	Anodized aluminum	1
Cover KA 41.1 FB/FG AB 084 1-2	0411084059	3.31	Anodized aluminum	1
Cover KA 41.1 FB/FG AB 096 1-2	0411096059	3.78	Anodized aluminum	1
Cover KA 41.1 FB/FG AB 107 1-2	0411107059	4.21	Anodized aluminum	1
Cover KA 41.1 FB/FG AB 121 1-2	0411121059	4.76	Anodized aluminum	1
Cover KA 41.1 FB/FG AB 133 1-2	0411133059	5.24	Anodized aluminum	1
Cover KA 41.1 FB/FG AB 144 1-2	0411144059	5.67	Anodized aluminum	1
Cover KA 41.1 FB/FG AB 146 1-2	0411146059	5.75	Anodized aluminum	1
Cover KA 41.1 FB/FG AB 158 1-2	0411158059	6.22	Anodized aluminum	1
Cover KA 41.1 FB/FG AB 171 1-2	0411171059	6.73	Anodized aluminum	1
Cover KA 41.1 FB/FG AB 182 1-2	0411182059	7.17	Anodized aluminum	1
Cover KA 41.1 FB/FG AB 196 1-2	0411196059	7.72	Anodized aluminum	1
Cover KA 41.1 FB/FG AB 220 1-2	0411220059	8.66	Anodized aluminum	1
Cover KA 41.1 FB/FG AB 246 1-2	0411246059	9.69	Anodized aluminum	1
Cover KA 41.1 FB/FG AB 296 1-2	0411296059	11.65	Anodized aluminum	1
Cover KA 41.1 FB/FG AB 346 1-2	0411346059	13.62	Anodized aluminum	1
Cover KA 41.1 FB/FG AB 396 1-2	0411396059	15.59	Anodized aluminum	1



MP 41.3 G - Accessories

Chain bracket cover

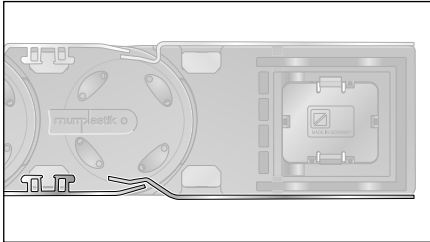

outside flexure curve

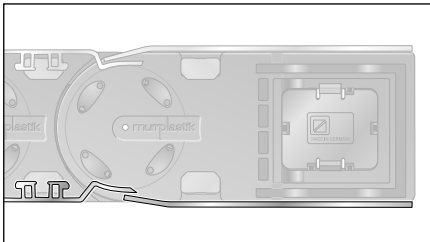

inside flexure curve

Type	Order no.	Inside width inch	Material	Pack qty.
Cover KA 41.1 FB/FG AB 062 2-2	0411062060	2.44	Anodized aluminum	1
Cover KA 41.1 FB/FG AB 071 2-2	0411071060	2.80	Anodized aluminum	1
Cover KA 41.1 FB/FG AB 084 2-2	0411084060	3.31	Anodized aluminum	1
Cover KA 41.1 FB/FG AB 096 2-2	0411096060	3.78	Anodized aluminum	1
Cover KA 41.1 FB/FG AB 107 2-2	0411107060	4.21	Anodized aluminum	1
Cover KA 41.1 FB/FG AB 121 2-2	0411121060	4.76	Anodized aluminum	1
Cover KA 41.1 FB/FG AB 133 2-2	0411133060	5.24	Anodized aluminum	1
Cover KA 41.1 FB/FG AB 144 2-2	0411144060	5.67	Anodized aluminum	1
Cover KA 41.1 FB/FG AB 146 2-2	0411146060	5.75	Anodized aluminum	1
Cover KA 41.1 FB/FG AB 158 2-2	0411158060	6.22	Anodized aluminum	1
Cover KA 41.1 FB/FG AB 171 2-2	0411171060	6.73	Anodized aluminum	1
Cover KA 41.1 FB/FG AB 182 2-2	0411182060	7.17	Anodized aluminum	1
Cover KA 41.1 FB/FG AB 196 2-2	0411196060	7.72	Anodized aluminum	1
Cover KA 41.1 FB/FG AB 220 2-2	0411220060	8.66	Anodized aluminum	1
Cover KA 41.1 FB/FG AB 246 2-2	0411246060	9.69	Anodized aluminum	1
Cover KA 41.1 FB/FG AB 296 2-2	0411296060	11.65	Anodized aluminum	1
Cover KA 41.1 FB/FG AB 346 2-2	0411346060	13.62	Anodized aluminum	1
Cover KA 41.1 FB/FG AB 396 2-2	0411396060	15.59	Anodized aluminum	1

Type	Order no.	Inside width inch	Material	Pack qty.
Cover KA 41.1 FB/FG IB 062 1-2	0411062057	2.44	Anodized aluminum	1
Cover KA 41.1 FB/FG IB 071 1-2	0411071057	2.80	Anodized aluminum	1
Cover KA 41.1 FB/FG IB 084 1-2	0411084057	3.31	Anodized aluminum	1
Cover KA 41.1 FB/FG IB 096 1-2	0411096057	3.78	Anodized aluminum	1
Cover KA 41.1 FB/FG IB 107 1-2	0411107057	4.21	Anodized aluminum	1
Cover KA 41.1 FB/FG IB 121 1-2	0411121057	4.76	Anodized aluminum	1
Cover KA 41.1 FB/FG IB 133 1-2	0411133057	5.24	Anodized aluminum	1
Cover KA 41.1 FB/FG IB 144 1-2	0411144057	5.67	Anodized aluminum	1
Cover KA 41.1 FB/FG IB 146 1-2	0411146057	5.75	Anodized aluminum	1
Cover KA 41.1 FB/FG IB 158 1-2	0411158057	6.22	Anodized aluminum	1
Cover KA 41.1 FB/FG IB 171 1-2	0411171057	6.73	Anodized aluminum	1
Cover KA 41.1 FB/FG IB 182 1-2	0411182057	7.17	Anodized aluminum	1
Cover KA 41.1 FB/FG IB 196 1-2	0411196057	7.72	Anodized aluminum	1
Cover KA 41.1 FB/FG IB 220 1-2	0411220057	8.66	Anodized aluminum	1
Cover KA 41.1 FB/FG IB 246 1-2	0411246057	9.69	Anodized aluminum	1
Cover KA 41.1 FB/FG IB 296 1-2	0411296057	11.65	Anodized aluminum	1
Cover KA 41.1 FB/FG IB 346 1-2	0411346057	13.62	Anodized aluminum	1
Cover KA 41.1 FB/FG IB 396 1-2	0411396057	15.59	Anodized aluminum	1

Chain bracket cover

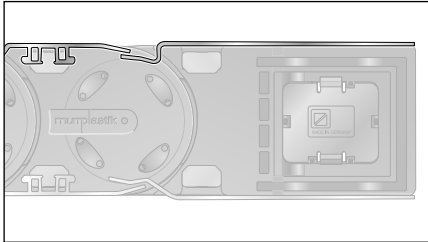

inside flexure curve

Type	Order no.	Inside width inch	Material	Pack qty.
Cover KA 41.1 FB/FG IB 062 2-2	0411062058	2.44	Anodized aluminum	1
Cover KA 41.1 FB/FG IB 071 2-2	0411071058	2.80	Anodized aluminum	1
Cover KA 41.1 FB/FG IB 084 2-2	0411084058	3.31	Anodized aluminum	1
Cover KA 41.1 FB/FG IB 096 2-2	0411096058	3.78	Anodized aluminum	1
Cover KA 41.1 FB/FG IB 107 2-2	0411107058	4.21	Anodized aluminum	1
Cover KA 41.1 FB/FG IB 121 2-2	0411121058	4.76	Anodized aluminum	1
Cover KA 41.1 FB/FG IB 133 2-2	0411133058	5.24	Anodized aluminum	1
Cover KA 41.1 FB/FG IB 144 2-2	0411144058	5.67	Anodized aluminum	1
Cover KA 41.1 FB/FG IB 146 2-2	0411146058	5.75	Anodized aluminum	1
Cover KA 41.1 FB/FG IB 158 2-2	0411158058	6.22	Anodized aluminum	1
Cover KA 41.1 FB/FG IB 171 2-2	0411171058	6.73	Anodized aluminum	1
Cover KA 41.1 FB/FG IB 182 2-2	0411182058	7.17	Anodized aluminum	1
Cover KA 41.1 FB/FG IB 196 2-2	0411196058	7.72	Anodized aluminum	1
Cover KA 41.1 FB/FG IB 220 2-2	0411220058	8.66	Anodized aluminum	1
Cover KA 41.1 FB/FG IB 246 2-2	0411246058	9.69	Anodized aluminum	1
Cover KA 41.1 FB/FG IB 296 2-2	0411296058	11.65	Anodized aluminum	1
Cover KA 41.1 FB/FG IB 346 2-2	0411346058	13.62	Anodized aluminum	1
Cover KA 41.1 FB/FG IB 396 2-2	0411396058	15.59	Anodized aluminum	1

Crossbar strain relief plate RS-ZL

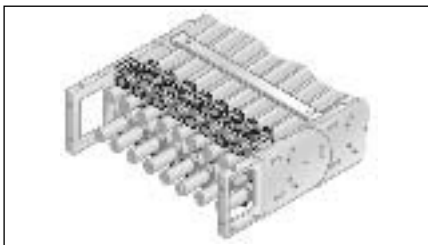

Crossbar strain relief plate RS-ZL

Type	Order no.	For internal width inch	Pack qty.
RS-ZL 045-5	052004500010	1.77	1
RS-ZL 062-5	052006200010	2.44	1
RS-ZL 071-5	052007100010	2.80	1
RS-ZL 084-5	052008400010	3.31	1
RS-ZL 096-5	052009600010	3.78	1
RS-ZL 107-5	052010700010	4.21	1
RS-ZL 121-5	052012100010	4.76	1
RS-ZL 133-5	052013300010	5.24	1
RS-ZL 5.67/5.75-5	052014400010	5.67/5.75	1
RS-ZL 158-5	052015800010	6.22	1
RS-ZL 171-5	052017100010	6.73	1
RS-ZL 182-5	052018200010	7.17	1
RS-ZL 196-5	052019600010	7.72	1
RS-ZL 220-5	052022000010	8.66	1
RS-ZL 246-5	052024600010	9.69	1

Fixed integrated frame bridge strain relief plates in the chain brackets. Tailored to all frame bridge widths up to 9.69 in (246 mm). May be assembled on the inside and outside flexure curves at both chain endings.



MP 41.3 G - Accessories

Strain relief type BAK

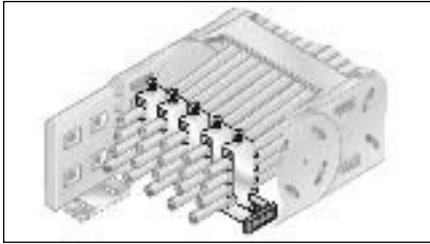

Strain relief with hooped clamp

Type	Order no.	Designation	Ø inch	Number of seats	Pack qty.
C-rail	81661610	C-profile rail			1
BA 12	81661036	BA 12 Hooped clamp	0.35–0.47	1	1
BAK 14	81661002	BAK 14 Hooped clamp	0.24–0.55	1	1
BAK 18	81661004	BAK 18 Hooped clamp	0.55–0.71	1	1
BAK 22	81661006	BAK 22 Hooped clamp	0.71–0.87	1	1
BAK 26	81661008	BAK 26 Hooped clamp	0.87–1.02	1	1
BAK 30	81661010	BAK 30 Hooped clamp	1.02–1.18	1	1
BAK 34	81661000	BAK 34 Hooped clamp	1.18–1.34	1	1
BAK 38	81661044	BAK 38 Hooped clamp	1.34–1.50	1	1
BAK 42	81661032	BAK 42 Hooped clamp	1.50–1.65	1	1
BAK 46	81661050	BAK 46 Hooped clamp	1.65–1.81	1	1
BA 12/2	81661038	BA 12/2 Hooped clamp	0.35–0.47	2	1
BAK 14/2	81661012	BAK 14/2 Hooped clamp	0.39–0.55	2	1
BAK 18/2	81661014	BAK 18/2 Hooped clamp	0.55–0.71	2	1
BAK 22/2	81661016	BAK 22/2 Hooped clamp	0.71–0.87	2	1
BAK 26/2	81661018	BAK 26/2 Hooped clamp	0.87–1.02	2	1
BAK 30/2	81661048	BAK 30/2 Hooped clamp	1.02–1.18	2	1
BAK 34/2	81661044	BAK 34/2 Hooped clamp	1.18–1.34	2	1
BAK 38/2	81661046	BAK 38/2 Hooped clamp	1.34–1.50	2	1
BAK 42/2	81661034	BAK 42/2 Hooped clamp	1.50–1.65	2	1
BAK 12/3	81661020	BAK 12/3 Hooped clamp	0.35–0.47	3	1
BAK 14/3	81661022	BAK 14/3 Hooped clamp	0.47–0.55	3	1
BAK 16/3	81661024	BAK 16/3 Hooped clamp	0.55–0.63	3	1
BAK 18/3	81661026	BAK 18/3 Hooped clamp	0.63–0.71	3	1
BAK 20/3	81661028	BAK 20/3 Hooped clamp	0.71–0.79	3	1
BAK 22/3	81661030	BAK 22/3 Hooped clamp	0.79–0.87	3	1

Fixed integrated strain relief in the chain connections. Available in all widths (also individual widths for aluminum frame ridges). May be assembled on the inside and outside flexure curves at both chain endings. Chain content is secured through hooped clamps that are available in different sizes. Material: Galvanized steel.

When ordering please indicate the type of chain and internal width.

Assembly

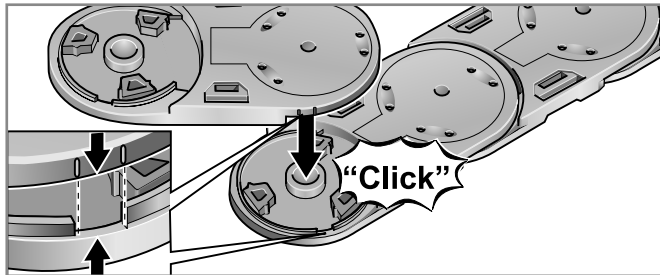

Step 1

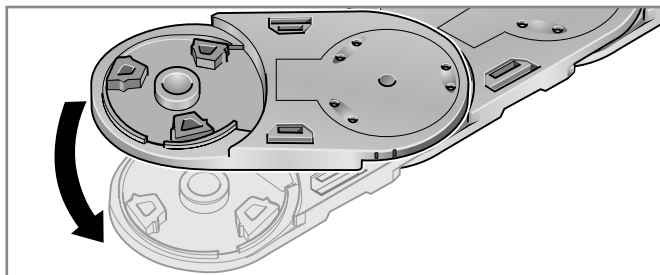

Step 2

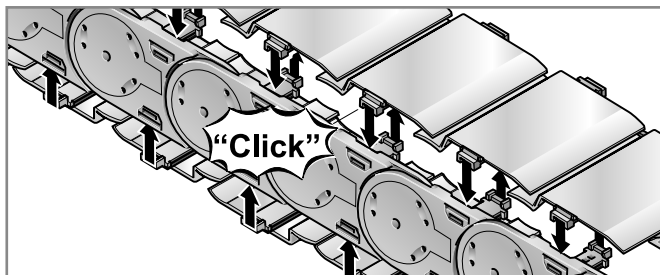

Step 3

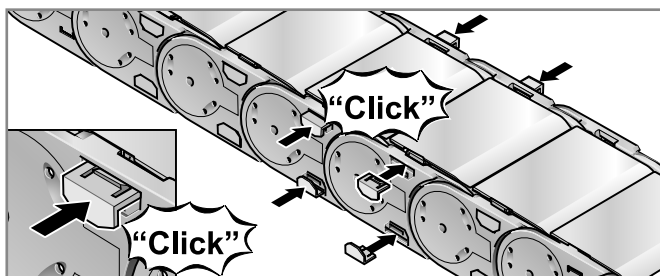

Step 4

Disassembly

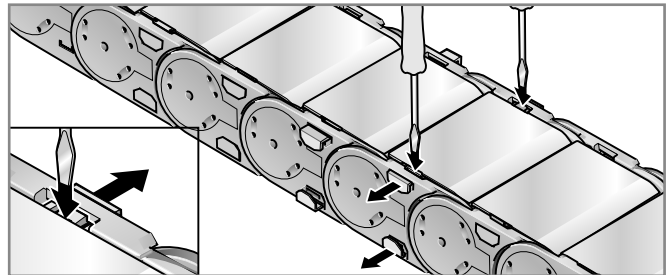

Step 1

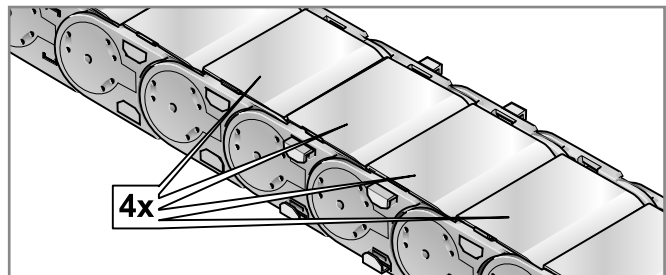

Step 2

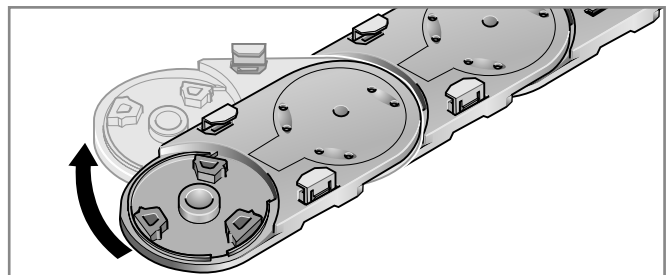

Step 3

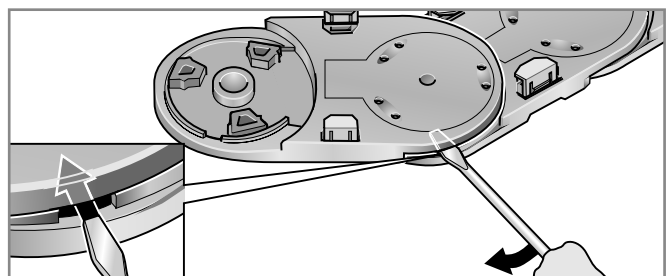

Step 4

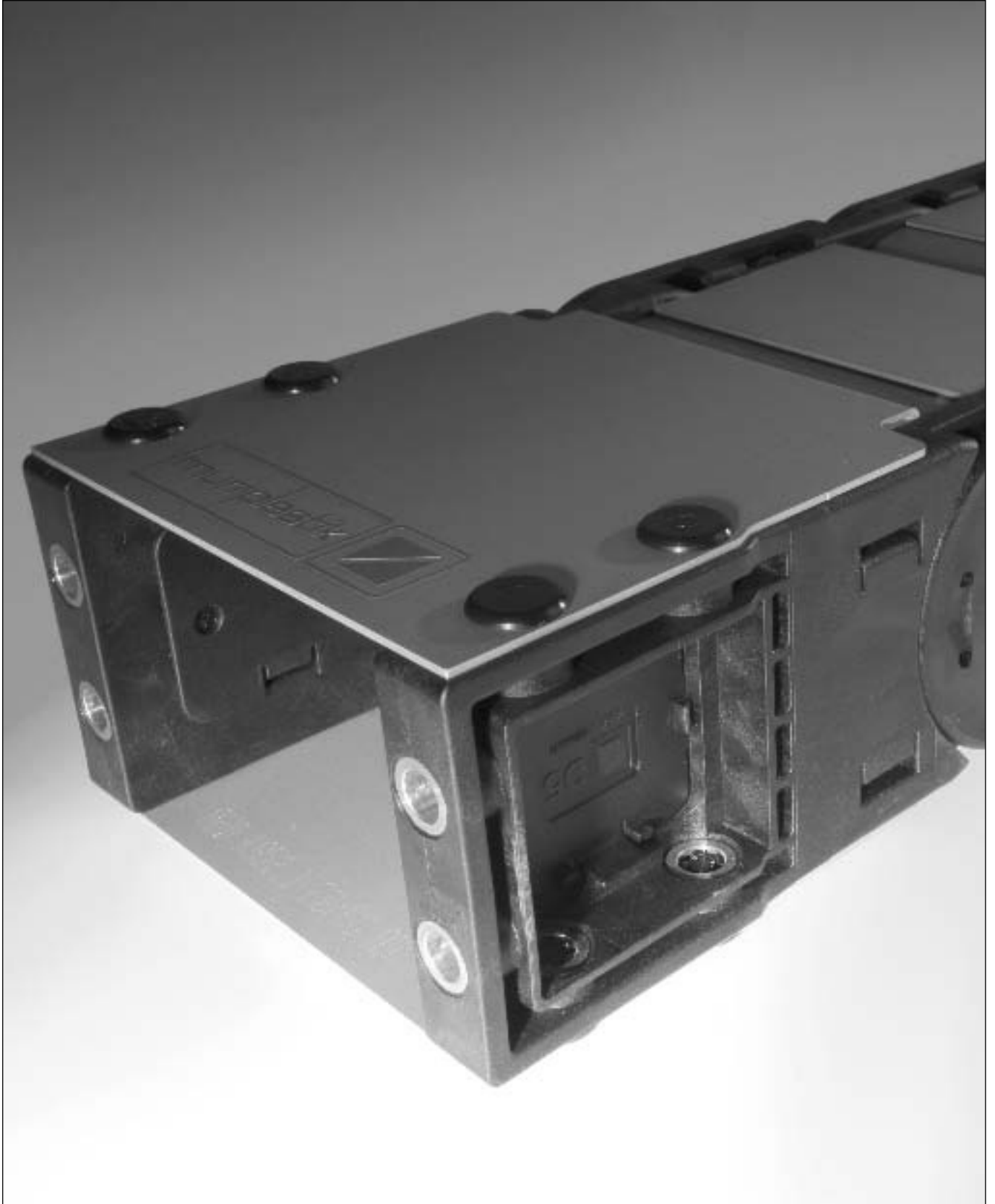

Cable drag chain systems

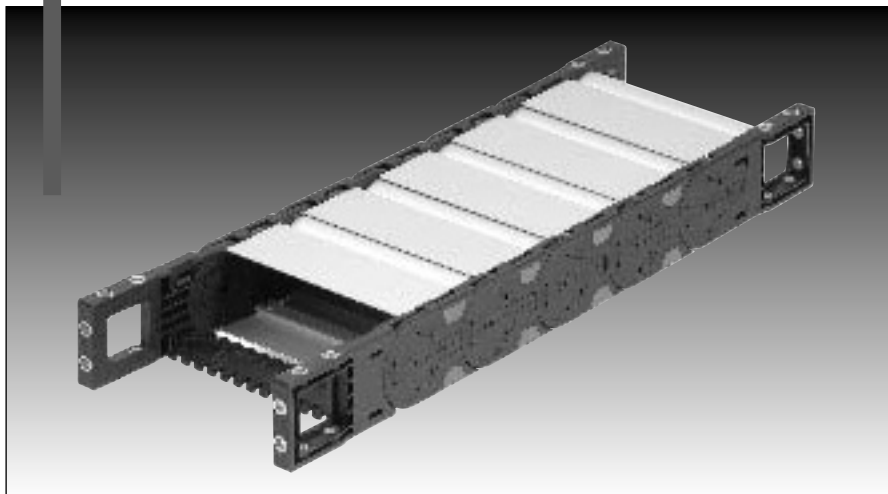

ClosedLine

MP 52.3 G



MP 52.3 G - ClosedLine

Order variants

Style (order code)						
Configuration (order code) * = standard						
Radius (order code) <small>The radii can be combined with any internal width</small>						
in mm						
Internal width (order code) <small># also available with plastic cover</small>						
in mm						
Outside width in mm						
MP52.3G 071	4.06	2.80	071			
MP52.3G 084	4.57	3.31	084			
MP52.3G 096	5.04	3.78	096#			
MP52.3G 107	5.47	4.21	107			
MP52.3G 121	6.02	4.76	121#			
MP52.3G 133	6.50	5.24	133			
MP52.3G 144	6.93	5.67	144			
MP52.3G 146	7.01	5.75	146#			
MP52.3G 158	7.48	6.22	158			
MP52.3G 171	7.99	6.73	171			
MP52.3G 182	8.43	7.17	182			
MP52.3G 196	8.98	7.72	196#			
MP52.3G 220	9.92	8.66	220	5.91	150	
MP52.3G 246	10.94	9.69	246#	6.89	175	
MP52.3G 296	12.91	11.65	296#	7.87	200	0
MP52.3G 346	14.88	13.62	346#	9.84	250	1
MP52.3G xxx	Inside	>3.78	Alu	11.81	300	4*
	+32	-23.62		13.78	350	5*
						0
						9

Order-Number:

Configuration:

- 0 PA crossbar every link; w/bias
- 1 PA crossbar every link; w/o bias
- 4* AL crossbar every link; w/bias
- 5* AL crossbar every link; w/o bias

Style:

- 0 Standard (PA/black)
- 9 Custom version

Sample order:

0523 071 150 0000

Internal width = 2.80 in (71 mm)
 Radius = 5.91 in (150 mm)
 Configuration = 0
 Style = 0

Ideal operating conditions:

- Extremely high accelerations
- Extremely high speeds
- Very high additional loads
- Long travel distances
- Extreme self-supporting lengths

Alternative chain type:

- MP 52.2 open series
- MP 65G for easier use

Features

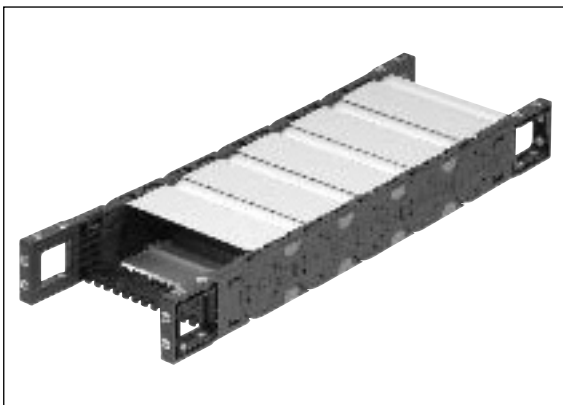

- Chain bracket, can be fastened on three sides
- Chain bracket with variably positionable metal angle
- Crossbar/cover can be removed from inside and outside flexure curve
- Side links with CLICK lock for easy opening
- Radii with or without bias (RV/RK)
- Crossbar strain relief can be integrated into chain bracket
- Aluminum frame bridges with integrated lock grid in variable lengths
- C-profile rail can be integrated into chain bracket
- Integrable separator for cable separation
- Foldable shelf system for reliable cable guidance

Technical data

Chain link dimensions (inch) (mm)

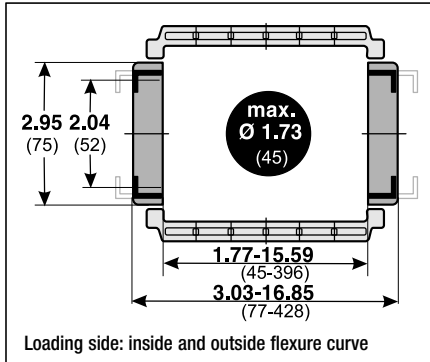

Material characteristics standard (PA/black)

Operating temperature: -22 to 248° F
 Gliding friction factor: 0.30
 Static friction factor: 0.45
 Fire classification: Based on UL94 HB

Other material properties on request

Technical specifications

Travel distance, gliding, L_g : 492.13 ft
 Travel distance, self-supporting, L_s : see diagram
 Travel distance, vertical, hanging, L_{vh} : 328.08 ft
 Travel distance, vertical, upright, L_{vu} : 19.69 ft
 Rotated 90°, self-supporting, L_{90r} : 9.84 ft
 Speed, gliding, V_g : 16.40 ft/s
 Speed, self-supporting, V_s : 65.62 ft/s
 Acceleration, gliding, a_g : 82.02 ft/s²
 Acceleration, self-supporting, a_s : 98.43 ft/s²

Self-supporting length

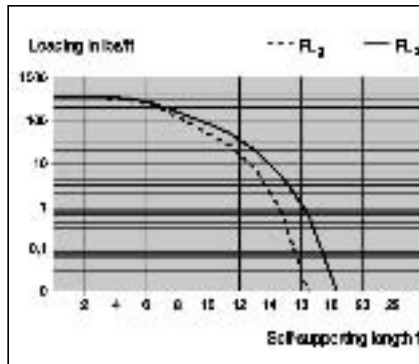
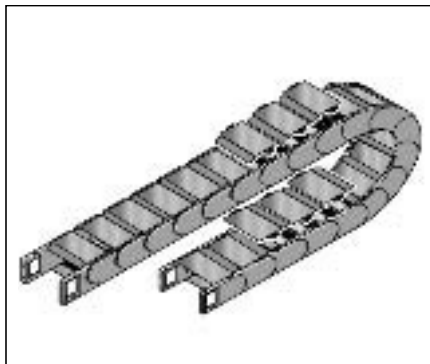

FL_g:
 Ideal installation situation for high stresses at the limit of the max. travel parameters. In this range the chain upper run is still biased, straight or has a max. sag of 0.39 – 1.97 in (10 – 50 mm) depending on the type of chain.

FL_b:
 Satisfactory installation position for many applications working in the lower to middle range of the max. travel parameters. Depending on the chain type, the sag of the chain upper run is >0.39 – 1.97 in (>10 – 50 mm) but certainly less than the max. sag.

If the sag is greater than FL_b, the arrangement is unsuitable and should be avoided. Please choose a more stable Murrplastik cable drag chain.

Determining the chain length

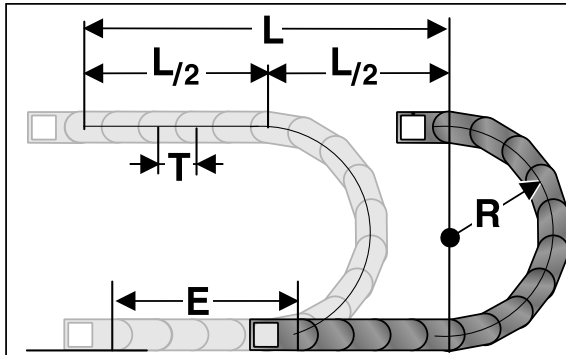

L = Travel distance
 R = Radius
 T = Pitch
 E = Distance between entry point and middle of travel distance

Determining the chain length

$$\text{Length} = \frac{L}{2} + \pi \times R + E$$

≈ 1 ft(m) chain = 4(11) links each 3.58 in (91 mm)

The fixed point of the cable drag chain should be connected in the middle of the travel distance. This arrangement gives the shortest connection between the fixed point and the moving point and thus the most efficient chain length.

Installation dimensions (in inch)

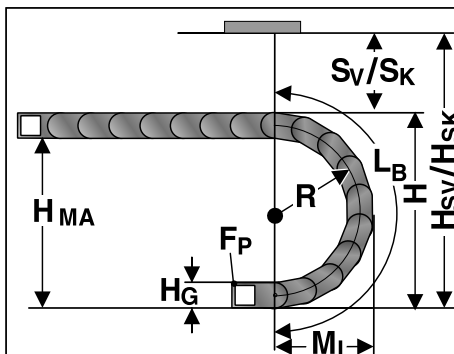

Radius R	5.91	6.89	7.87	9.84	11.81	13.78
Outside height of chain link (H_o)	2.95	2.95	2.95	2.95	2.95	2.95
Height of bend (H)	15.94	17.91	19.88	23.82	27.76	31.69
Height of moving end connection (H_{MA})	12.99	14.96	16.93	20.87	24.80	28.74
Safety margin with bias (S_v)	1.97	1.97	1.97	1.97	1.97	1.97
Installation height with bias (H_{sv})	17.91	19.88	21.85	25.79	29.72	33.66
Safety margin without bias (S_k)	0.79	0.79	0.79	0.79	0.79	0.79
Installation height without bias (H_{sk})	16.73	18.70	20.67	24.61	28.54	32.48
Arc projection (M_l)	11.57	12.52	13.54	15.51	17.48	19.45
Bend length (L_b)	28.62	31.69	34.80	40.98	47.17	53.35



MP 52.3 G - ClosedLine

Chain bracket

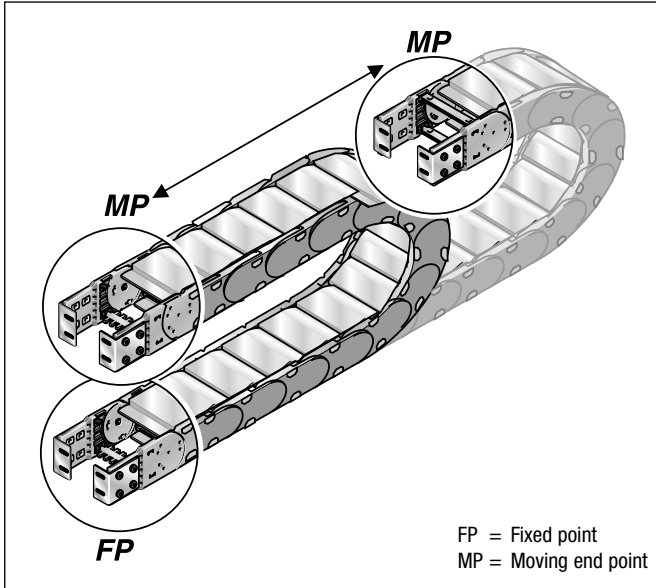

Flexible chain bracket

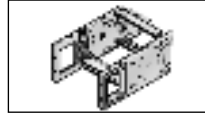

Chain bracket angle

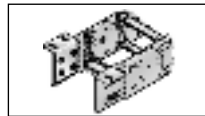

Top/Outside

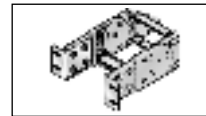

Front/Outside

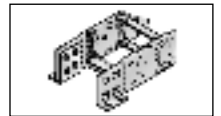

Bottom/Outside

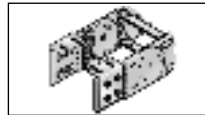

Top/Inside

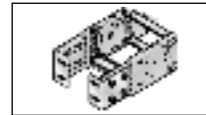

Front/Inside

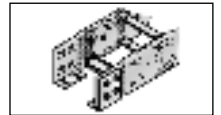

Bottom/Inside

Flexible chain bracket

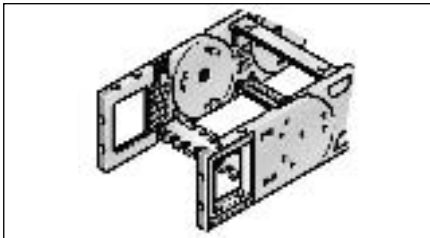

Type	Order no.	Version	Pack qty.
KA 52.1-FB	0521000056	with bushing	1
KA 52.1-FB	0521000057	with bushing	1
KA 52.1-FG	0521000058	with thread	1
KA 52.1-FG	0521000059	with thread	1

This chain bracket offers universal connection options (top, bottom and front) and is attached to the ends of the chain like a side link. This allows the chain to move right up to the bracket. Each chain requires one male and one female bracket. M6 screws are used to secure the brackets in place. Extrusion-coated metal bushings with either a through-hole (-FB) or a threaded hole (-FG) ensure the permanent, high-strength transmission of even extreme forces onto the cable drag chain.

Chain bracket angle

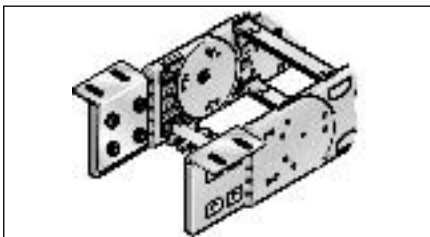

Type	Order no.	Pack qty.
KA 52.1 Female end	0521000050	1
KA 52.1 Male end	0521000051	1

There are several options regarding the chain bracket. The fixed-point bracket (inside/bottom) and the moving end bracket (inside/top) are supplied as standard. However, any other combination can be supplied upon request. The chain bracket is fastened at the end like a side link. This enables the chain to move right up to the bracket. Each chain requires one male and one female bracket. The brackets should be fastened with M6 screws.

Flexible chain bracket

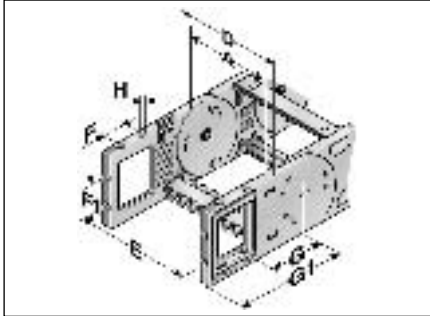

Flexible with through-hole

Type	A inch	D inch	E inch	F inch	F1 inch	G inch	G1 inch	H Ø inch
KA52.1-FB	2.80	4.21	3.43	1.38	1.18	3.50	5.67	0.33
KA52.1-FB	3.31	4.72	3.94	1.38	1.18	3.50	5.67	0.33
KA52.1-FB	3.78	5.20	4.41	1.38	1.18	3.50	5.67	0.33
KA52.1-FB	4.21	5.63	4.84	1.38	1.18	3.50	5.67	0.33
KA52.1-FB	4.76	6.22	5.39	1.38	1.18	3.50	5.67	0.33
KA52.1-FB	5.24	6.65	5.87	1.38	1.18	3.50	5.67	0.33
KA52.1-FB	5.67	7.09	6.30	1.38	1.18	3.50	5.67	0.33
KA52.1-FB	5.75	7.17	6.38	1.38	1.18	3.50	5.67	0.33
KA52.1-FB	6.22	7.64	6.85	1.38	1.18	3.50	5.67	0.33
KA52.1-FB	6.73	8.15	7.36	1.38	1.18	3.50	5.67	0.33
KA52.1-FB	7.17	8.58	7.80	1.38	1.18	3.50	5.67	0.33
KA52.1-FB	7.72	9.13	8.35	1.38	1.18	3.50	5.67	0.33
KA52.1-FB	8.66	10.08	9.29	1.38	1.77	3.50	5.67	0.33
KA52.1-FB	9.69	11.10	10.31	1.38	1.77	3.50	5.67	0.33
KA52.1-FB	11.65	13.07	12.28	1.38	1.77	3.50	5.67	0.33
KA52.1-FB	13.62	15.04	14.25	1.38	1.77	3.50	5.67	0.33
KA52.1-FB	variable	A+1.42	A+0.63	1.38	1.18	3.50	5.67	0.33

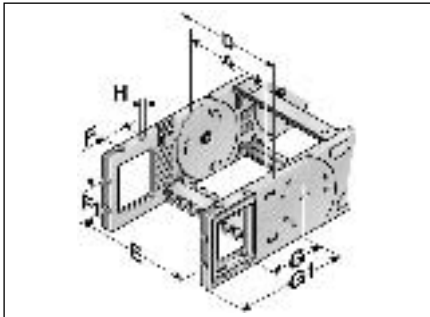

Flexible with threaded bushing

Type	A inch	D inch	E inch	F inch	F1 inch	G inch	G1 inch	H
KA52.1-FG	2.80	4.21	3.43	1.38	1.18	3.50	5.67	M8
KA52.1-FG	3.31	4.72	3.94	1.38	1.18	3.50	5.67	M8
KA52.1-FG	3.78	5.20	4.41	1.38	1.18	3.50	5.67	M8
KA52.1-FG	4.21	5.63	4.84	1.38	1.18	3.50	5.67	M8
KA52.1-FG	4.76	6.22	5.39	1.38	1.18	3.50	5.67	M8
KA52.1-FG	5.24	6.65	5.87	1.38	1.18	3.50	5.67	M8
KA52.1-FG	5.67	7.09	6.30	1.38	1.18	3.50	5.67	M8
KA52.1-FG	5.75	7.17	6.38	1.38	1.18	3.50	5.67	M8
KA52.1-FG	6.22	7.64	6.85	1.38	1.18	3.50	5.67	M8
KA52.1-FG	6.73	8.15	7.36	1.38	1.18	3.50	5.67	M8
KA52.1-FG	7.17	8.58	7.80	1.38	1.18	3.50	5.67	M8
KA52.1-FG	7.72	9.13	8.35	1.38	1.18	3.50	5.67	M8
KA52.1-FG	8.66	10.08	9.29	1.38	1.18	3.50	5.67	M8
KA52.1-FG	9.69	11.10	10.31	1.38	1.18	3.50	5.67	M8
KA52.1-FG	11.65	13.07	12.28	1.38	1.77	3.50	5.67	M8
KA52.1-FG	13.62	15.04	14.25	1.38	1.77	3.50	5.67	M8
KA52.1-FG	variable	A+1.42	A+0.63	1.38	1.18	3.50	5.67	M8



MP 52.3 G - ClosedLine

Chain bracket angle

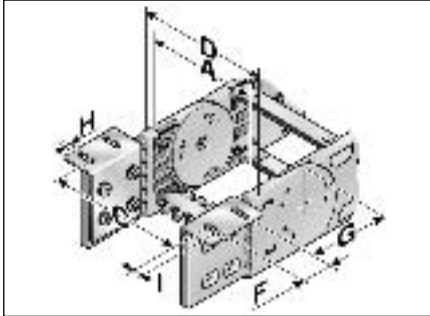

Bottom and top/outside

Type	A inch	C inch	D inch	F inch	G inch	H Ø inch	I inch
KA 52.1	2.80	4.15	4.06	1.26	3.76	0.26	0.55
KA 52.1	3.31	4.67	4.33	1.26	3.76	0.26	0.55
KA 52.1	3.78	5.14	5.04	1.26	3.76	0.26	0.55
KA 52.1	4.21	5.57	5.47	1.26	3.76	0.26	0.55
KA 52.1	4.76	6.12	6.02	1.26	3.76	0.26	0.55
KA 52.1	5.24	6.59	6.5	1.26	3.76	0.26	0.55
KA 52.1	5.67	7.03	6.93	1.26	3.76	0.26	0.55
KA 52.1	5.75	7.11	7.01	1.26	3.76	0.26	0.55
KA 52.1	6.22	7.58	7.48	1.26	3.76	0.26	0.55
KA 52.1	6.73	8.09	7.99	1.26	3.76	0.26	0.55
KA 52.1	7.17	8.50	8.39	1.26	3.76	0.26	0.55
KA 52.1	7.72	9.07	8.98	1.26	3.76	0.26	0.55
KA 52.1	8.66	10.02	20.67	1.26	3.76	0.26	0.55
KA 52.1	9.69	11.04	10.94	1.26	3.76	0.26	0.55
KA 52.1	11.65	13.01	12.91	1.26	3.76	0.26	0.55
KA 52.1	13.62	14.98	14.88	1.26	3.76	0.26	0.55
KA 52.1	variable	A+1.36	A+1.26	1.26	3.76	0.26	0.55

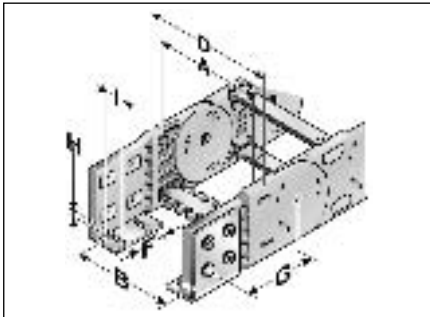

Bottom and top/inside

Type	A inch	C inch	D inch	F inch	G inch	H Ø inch	I inch
KA 52.1	2.80	2.70	4.06	1.26	3.76	0.26	0.55
KA 52.1	3.31	3.21	4.57	1.26	3.76	0.26	0.55
KA 52.1	3.78	3.68	5.04	1.26	3.76	0.26	0.55
KA 52.1	4.21	4.11	5.47	1.26	3.76	0.26	0.55
KA 52.1	4.76	4.67	6.02	1.26	3.76	0.26	0.55
KA 52.1	5.24	5.18	6.5	1.26	3.76	0.26	0.55
KA 52.1	5.67	5.57	6.93	1.26	3.76	0.26	0.55
KA 52.1	5.75	5.65	7.01	1.26	3.76	0.26	0.55
KA 52.1	6.22	6.12	7.48	1.26	3.76	0.26	0.55
KA 52.1	6.73	6.63	7.99	1.26	3.76	0.26	0.55
KA 52.1	7.17	7.07	8.39	1.26	3.76	0.26	0.55
KA 52.1	7.72	7.62	8.98	1.26	3.76	0.26	0.55
KA 52.1	8.66	8.56	20.67	1.26	3.76	0.26	0.55
KA 52.1	9.69	9.59	10.94	1.26	3.76	0.26	0.55
KA 52.1	11.65	11.56	12.91	1.26	3.76	0.26	0.55
KA 52.1	13.62	13.52	14.88	1.26	3.76	0.26	0.55
KA 52.1	variable	A+0.10	A+1.26	1.26	3.76	0.26	0.55

Chain bracket angle

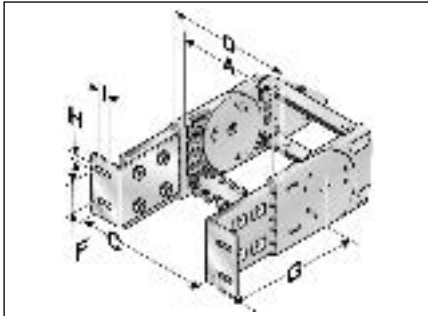

Front/Outside

Type	A inch	C inch	D inch	F inch	G inch	H Ø inch	I inch
KA 52.1	2.80	4.15	4.06	1.26	5.87	0.26	0.55
KA 52.1	3.31	4.67	4.57	1.26	5.87	0.26	0.55
KA 52.1	3.78	5.14	5.04	1.26	5.87	0.26	0.55
KA 52.1	4.21	5.57	5.47	1.26	5.87	0.26	0.55
KA 52.1	4.76	6.12	6.02	1.26	5.87	0.26	0.55
KA 52.1	5.24	6.59	6.5	1.26	5.87	0.26	0.55
KA 52.1	5.67	7.03	6.93	1.26	5.87	0.26	0.55
KA 52.1	5.75	7.11	7.01	1.26	5.87	0.26	0.55
KA 52.1	6.22	7.58	7.48	1.26	5.87	0.26	0.55
KA 52.1	6.73	8.09	7.99	1.26	5.87	0.26	0.55
KA 52.1	7.17	8.50	8.39	1.26	5.87	0.26	0.55
KA 52.1	7.72	9.07	8.98	1.26	5.87	0.26	0.55
KA 52.1	8.66	10.02	20.67	1.26	5.87	0.26	0.55
KA 52.1	9.69	11.04	10.94	1.26	5.87	0.26	0.55
KA 52.1	11.65	13.01	12.91	1.26	5.87	0.26	0.55
KA 52.1	13.62	14.98	14.88	1.26	5.87	0.26	0.55
KA 52.1	variable	A+1.36	A+1.26	1.26	5.87	0.26	0.55

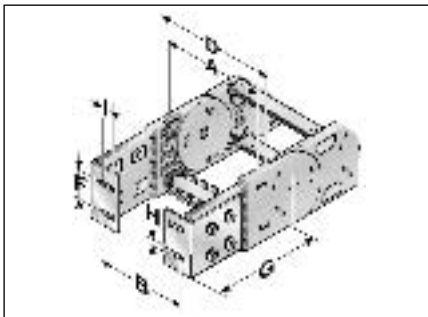

Front/Inside

Type	A inch	C inch	D inch	F inch	G inch	H Ø inch	I inch
KA 52.1	3.19	2.70	4.06	1.26	5.87	0.26	0.55
KA 52.1	3.31	3.21	4.57	1.26	5.87	0.26	0.55
KA 52.1	3.78	3.68	5.04	1.26	5.87	0.26	0.55
KA 52.1	4.21	4.11	5.47	1.26	5.87	0.26	0.55
KA 52.1	4.76	4.67	6.02	1.26	5.87	0.26	0.55
KA 52.1	5.24	5.18	6.5	1.26	5.87	0.26	0.55
KA 52.1	5.67	5.57	6.93	1.26	5.87	0.26	0.55
KA 52.1	5.75	5.65	7.01	1.26	5.87	0.26	0.55
KA 52.1	6.22	6.12	7.48	1.26	5.87	0.26	0.55
KA 52.1	6.73	6.63	7.99	1.26	5.87	0.26	0.55
KA 52.1	7.17	7.07	8.39	1.26	5.87	0.26	0.55
KA 52.1	7.72	7.62	8.98	1.26	5.87	0.26	0.55
KA 52.1	8.66	8.56	20.67	1.26	5.87	0.26	0.55
KA 52.1	9.69	9.59	10.94	1.26	5.87	0.26	0.55
KA 52.1	11.65	11.56	12.91	1.26	5.87	0.26	0.55
KA 52.1	13.62	13.52	14.88	1.26	5.87	0.26	0.55
KA 52.1	variable	A+0.10	A+1.26	1.26	5.87	0.26	0.55



MP 52.3 G - Accessories

Separator

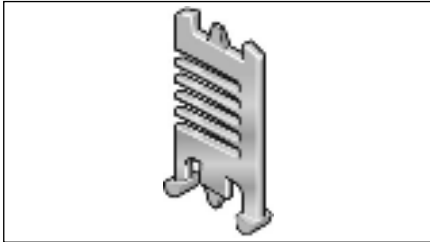

Separator

Type	Order no.	Designation	Lock grid spacing inch	Pack qty.
TR 52.1	052100009200	TR 52.1 Separator	0.22	1

We recommend that separators be used if multiple round cables or conduits with differing diameters are to be installed. An offset configuration of the separators is advisable.

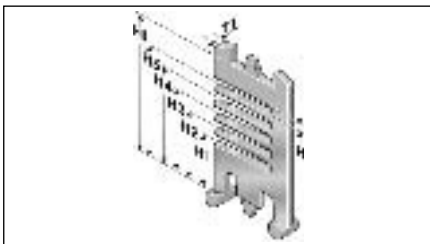

Separator

Type	TI inch	H inch	H1 inch	H2 inch	H3 inch	H4 inch	H5 inch	HI inch
TR 52.1	0.14	0.16	0.61	0.87	1.11	1.36	1.61	2.05

Shelving system

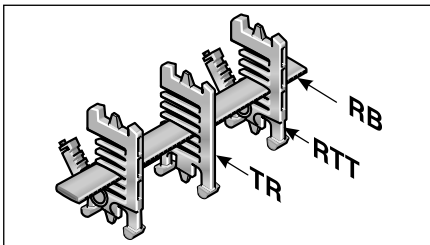

Shelving system

Type	Order no.	Designation	Width inch	Lock grid spacing inch	Pack qty.
RB 028-5	100000002800	RB 028-5 Shelf	1.10	0.22	1
RB 056-5	100000005600	RB 056-5 Shelf	2.20	0.22	1
RB 084-5	100000008400	RB 084-5 Shelf	3.31	0.22	1
RB 112-5	100000011200	RB 112-5 Shelf	4.41	0.22	1
RB 140-5	100000014000	RB 140-5 Shelf	5.51	0.22	1
RB 168-5	100000016800	RB 168-5 Shelf	6.61	0.22	1
RB 196-5	100000019600	RB 196-5 Shelf	7.72	0.22	1
RTT 52	100090522000	RTT 52 Shelf support, divisible		0.22	1

In connection with at least two shelf supports (RTT) the shelf becomes a shelving system. The additional levels prevent cables from criss-crossing and therefore destroying each other, while also avoiding excessive friction. Pre-assembly is not necessary as the shelving system and cabling can be assembled quickly and easily on site.

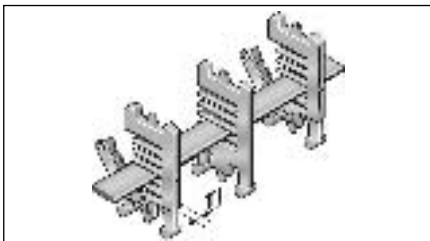

Shelving system

Type	TI inch
RTT 52	0.28

Chain bracket cover D5

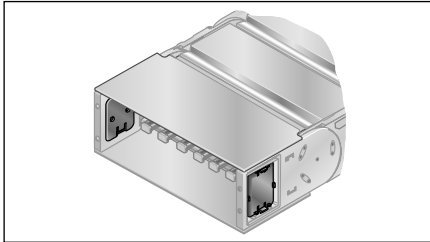

Side link cover

Type	Order no.	Pack qty.
Cover D5 KA 52.1-FB/FG	0523888002	2

Self-locking covers close the side mounting window on the flexible chain bracket (KA-FB/FG).

Chain bracket cover

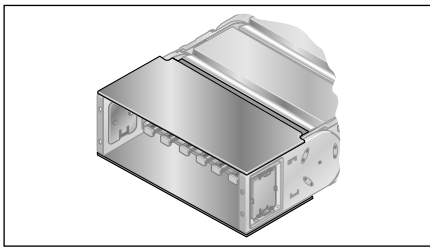

Covers for the flexible chain bracket (KA-FB/FG) allow for a closed variant up to the chain's end.

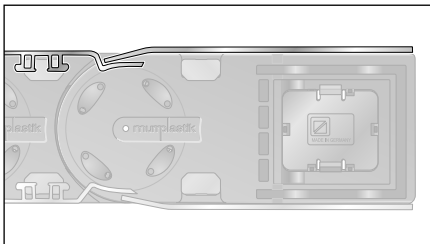

Outside flexure curve

Type	Order no.	Inside width inch	Material	Pack qty.
Cover KA 52.1 FB/FG AB 062 1-2	0521062059	2.44	Anodized aluminum	1
Cover KA 52.1 FB/FG AB 071 1-2	0521071059	2.80	Anodized aluminum	1
Cover KA 52.1 FB/FG AB 084 1-2	0521084059	3.31	Anodized aluminum	1
Cover KA 52.1 FB/FG AB 096 1-2	0521096059	3.78	Anodized aluminum	1
Cover KA 52.1 FB/FG AB 107 1-2	0521107059	4.21	Anodized aluminum	1
Cover KA 52.1 FB/FG AB 121 1-2	0521121059	4.76	Anodized aluminum	1
Cover KA 52.1 FB/FG AB 133 1-2	0521133059	5.24	Anodized aluminum	1
Cover KA 52.1 FB/FG AB 144 1-2	0521144059	5.67	Anodized aluminum	1
Cover KA 52.1 FB/FG AB 146 1-2	0521146059	5.75	Anodized aluminum	1
Cover KA 52.1 FB/FG AB 158 1-2	0521158059	6.22	Anodized aluminum	1
Cover KA 52.1 FB/FG AB 171 1-2	0521171059	6.73	Anodized aluminum	1
Cover KA 52.1 FB/FG AB 182 1-2	0521182059	7.17	Anodized aluminum	1
Cover KA 52.1 FB/FG AB 196 1-2	0521196059	7.72	Anodized aluminum	1
Cover KA 52.1 FB/FG AB 220 1-2	0521220059	8.66	Anodized aluminum	1
Cover KA 52.1 FB/FG AB 246 1-2	0521246059	9.69	Anodized aluminum	1
Cover KA 52.1 FB/FG AB 296 1-2	0521296059	11.65	Anodized aluminum	1
Cover KA 52.1 FB/FG AB 346 1-2	0521346059	13.62	Anodized aluminum	1
Cover KA 52.1 FB/FG AB 396 1-2	0521396059	15.59	Anodized aluminum	1



MP 52.3 G - Accessories

Chain bracket cover

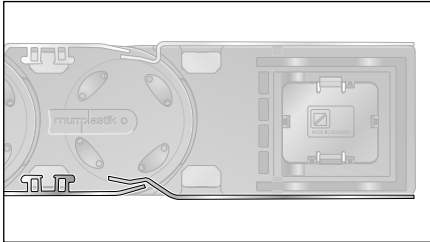

outside flexure curve

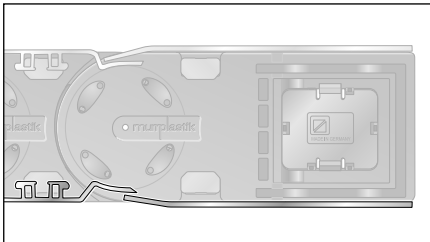

inside flexure curve

Type	Order no.	Inside width inch	Material	Pack qty.
Cover KA 52.1 FB/FG AB 062 2-2	0521062060	2.44	Anodized aluminum	1
Cover KA 52.1 FB/FG AB 071 2-2	0521071060	2.80	Anodized aluminum	1
Cover KA 52.1 FB/FG AB 084 2-2	0521084060	3.31	Anodized aluminum	1
Cover KA 52.1 FB/FG AB 096 2-2	0521096060	3.78	Anodized aluminum	1
Cover KA 52.1 FB/FG AB 107 2-2	0521107060	4.21	Anodized aluminum	1
Cover KA 52.1 FB/FG AB 121 2-2	0521121060	4.76	Anodized aluminum	1
Cover KA 52.1 FB/FG AB 133 2-2	0521133060	5.24	Anodized aluminum	1
Cover KA 52.1 FB/FG AB 144 2-2	0521144060	5.67	Anodized aluminum	1
Cover KA 52.1 FB/FG AB 146 2-2	0521146060	5.75	Anodized aluminum	1
Cover KA 52.1 FB/FG AB 158 2-2	0521158060	6.22	Anodized aluminum	1
Cover KA 52.1 FB/FG AB 171 2-2	0521171060	6.73	Anodized aluminum	1
Cover KA 52.1 FB/FG AB 182 2-2	0521182060	7.17	Anodized aluminum	1
Cover KA 52.1 FB/FG AB 196 2-2	0521196060	7.72	Anodized aluminum	1
Cover KA 52.1 FB/FG AB 220 2-2	0521220060	8.66	Anodized aluminum	1
Cover KA 52.1 FB/FG AB 246 2-2	0521246060	9.69	Anodized aluminum	1
Cover KA 52.1 FB/FG AB 296 2-2	0521296060	11.65	Anodized aluminum	1
Cover KA 52.1 FB/FG AB 346 2-2	0521346060	13.62	Anodized aluminum	1
Cover KA 52.1 FB/FG AB 396 2-2	0521396060	15.59	Anodized aluminum	1

Type	Order no.	Inside width inch	Material	Pack qty.
Cover KA 52.1 FB/FG IB 062 1-2	0521062057	2.44	Anodized aluminum	1
Cover KA 52.1 FB/FG IB 071 1-2	0521071057	2.80	Anodized aluminum	1
Cover KA 52.1 FB/FG IB 084 1-2	0521084057	3.31	Anodized aluminum	1
Cover KA 52.1 FB/FG IB 096 1-2	0521096057	3.78	Anodized aluminum	1
Cover KA 52.1 FB/FG IB 107 1-2	0521107057	4.21	Anodized aluminum	1
Cover KA 52.1 FB/FG IB 121 1-2	0521121057	4.76	Anodized aluminum	1
Cover KA 52.1 FB/FG IB 133 1-2	0521133057	5.24	Anodized aluminum	1
Cover KA 52.1 FB/FG IB 144 1-2	0521144057	5.67	Anodized aluminum	1
Cover KA 52.1 FB/FG IB 146 1-2	0521146057	5.75	Anodized aluminum	1
Cover KA 52.1 FB/FG IB 158 1-2	0521158057	6.22	Anodized aluminum	1
Cover KA 52.1 FB/FG IB 171 1-2	0521171057	6.73	Anodized aluminum	1
Cover KA 52.1 FB/FG IB 182 1-2	0521182057	7.17	Anodized aluminum	1
Cover KA 52.1 FB/FG IB 196 1-2	0521196057	7.72	Anodized aluminum	1
Cover KA 52.1 FB/FG IB 220 1-2	0521220057	8.66	Anodized aluminum	1
Cover KA 52.1 FB/FG IB 246 1-2	0521246057	9.69	Anodized aluminum	1
Cover KA 52.1 FB/FG IB 296 1-2	0521296057	11.65	Anodized aluminum	1
Cover KA 52.1 FB/FG IB 346 1-2	0521346057	13.62	Anodized aluminum	1
Cover KA 52.1 FB/FG IB 396 1-2	0521396057	15.59	Anodized aluminum	1

Chain bracket cover

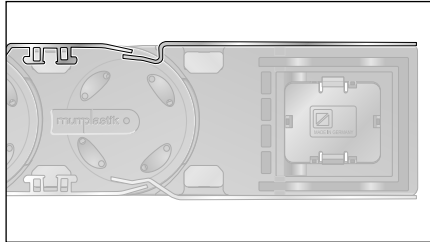

inside flexure curve

Type	Order no.	Inside width inch	Material	Pack qty.
Cover KA 52.1 FB/FG IB 062 2-2	0521062058	2.44	Anodized aluminum	1
Cover KA 52.1 FB/FG IB 071 2-2	0521071058	2.80	Anodized aluminum	1
Cover KA 52.1 FB/FG IB 084 2-2	0521084058	3.31	Anodized aluminum	1
Cover KA 52.1 FB/FG IB 096 2-2	0521096058	3.78	Anodized aluminum	1
Cover KA 52.1 FB/FG IB 107 2-2	0521107058	4.21	Anodized aluminum	1
Cover KA 52.1 FB/FG IB 121 2-2	0521121058	4.76	Anodized aluminum	1
Cover KA 52.1 FB/FG IB 133 2-2	0521133058	5.24	Anodized aluminum	1
Cover KA 52.1 FB/FG IB 144 2-2	0521144058	5.67	Anodized aluminum	1
Cover KA 52.1 FB/FG IB 146 2-2	0521146058	5.75	Anodized aluminum	1
Cover KA 52.1 FB/FG IB 158 2-2	0521158058	6.22	Anodized aluminum	1
Cover KA 52.1 FB/FG IB 171 2-2	0521171058	6.73	Anodized aluminum	1
Cover KA 52.1 FB/FG IB 182 2-2	0521182058	7.17	Anodized aluminum	1
Cover KA 52.1 FB/FG IB 196 2-2	0521196058	7.72	Anodized aluminum	1
Cover KA 52.1 FB/FG IB 220 2-2	0521220058	8.66	Anodized aluminum	1
Cover KA 52.1 FB/FG IB 246 2-2	0521246058	9.69	Anodized aluminum	1
Cover KA 52.1 FB/FG IB 296 2-2	0521296058	11.65	Anodized aluminum	1
Cover KA 52.1 FB/FG IB 346 2-2	0521346058	13.62	Anodized aluminum	1
Cover KA 52.1 FB/FG IB 396 2-2	0521396058	15.59	Anodized aluminum	1

Crossbar strain relief plate RS-ZL

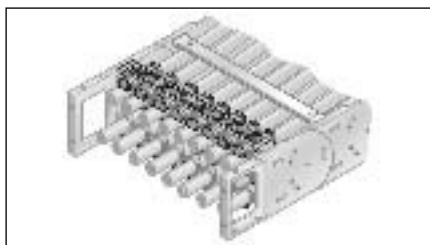

Crossbar strain relief plate RS-ZL

Type	Order no.	For internal width inch	Pack qty.
RS-ZL 045-5	052004500010	1.77	1
RS-ZL 062-5	052006200010	2.44	1
RS-ZL 071-5	052007100010	2.80	1
RS-ZL 084-5	052008400010	3.31	1
RS-ZL 096-5	052009600010	3.78	1
RS-ZL 107-5	052010700010	4.21	1
RS-ZL 121-5	052012100010	4.76	1
RS-ZL 133-5	052013300010	5.24	1
RS-ZL 144/146-5	052014400010	5.67/5.75	1
RS-ZL 158-5	052015800010	6.22	1
RS-ZL 171-5	052017100010	6.73	1
RS-ZL 182-5	052018200010	7.17	1
RS-ZL 196-5	052019600010	7.72	1
RS-ZL 220-5	052022000010	8.66	1
RS-ZL 246-5	052024600010	9.69	1

Fixed integrated frame bridge strain relief plates in the chain brackets. Tailored to all frame bridge widths up to 9.69 in (246 mm). May be assembled on the inside and outside flexure curves at both chain endings.



MP 52.3 G - Accessories

Strain relief type BAK

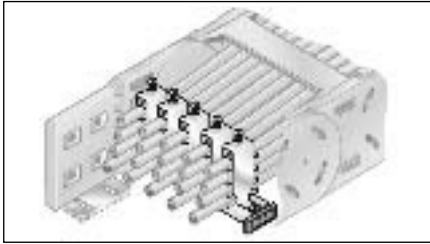

Strain relief with hooped clamp

Type	Order no.	Designation	Ø inch	Number of seats	Pack qty.
C-rail	81661610	C-profile rail			1
BA 12	81661036	BA 12 Hooped clamp	0.35–0.47	1	1
BAK 14	81661002	BAK 14 Hooped clamp	0.24–0.55	1	1
BAK 18	81661004	BAK 18 Hooped clamp	0.55–0.71	1	1
BAK 22	81661006	BAK 22 Hooped clamp	0.71–0.87	1	1
BAK 26	81661008	BAK 26 Hooped clamp	0.87–1.02	1	1
BAK 30	81661010	BAK 30 Hooped clamp	1.02–1.18	1	1
BAK 34	81661000	BAK 34 Hooped clamp	1.18–1.34	1	1
BAK 38	81661044	BAK 38 Hooped clamp	1.34–1.50	1	1
BAK 42	81661032	BAK 42 Hooped clamp	1.50–1.65	1	1
BAK 46	81661050	BAK 46 Hooped clamp	1.65–1.81	1	1
BA 12/2	81661038	BA 12/2 Hooped clamp	0.35–0.47	2	1
BAK 14/2	81661012	BAK 14/2 Hooped clamp	0.39–0.55	2	1
BAK 18/2	81661014	BAK 18/2 Hooped clamp	0.55–0.71	2	1
BAK 22/2	81661016	BAK 22/2 Hooped clamp	0.71–0.87	2	1
BAK 26/2	81661018	BAK 26/2 Hooped clamp	0.87–1.02	2	1
BAK 30/2	81661048	BAK 30/2 Hooped clamp	1.02–1.18	2	1
BAK 34/2	81661044	BAK 34/2 Hooped clamp	1.18–1.34	2	1
BAK 38/2	81661046	BAK 38/2 Hooped clamp	1.34–1.50	2	1
BAK 42/2	81661034	BAK 42/2 Hooped clamp	1.50–1.65	2	1
BAK 12/3	81661020	BAK 12/3 Hooped clamp	0.35–0.47	3	1
BAK 14/3	81661022	BAK 14/3 Hooped clamp	0.47–0.55	3	1
BAK 16/3	81661024	BAK 16/3 Hooped clamp	0.55–0.63	3	1
BAK 18/3	81661026	BAK 18/3 Hooped clamp	0.63–0.71	3	1
BAK 20/3	81661028	BAK 20/3 Hooped clamp	0.71–0.79	3	1
BAK 22/3	81661030	BAK 22/3 Hooped clamp	0.79–0.87	3	1

Fixed integrated strain relief in the chain connections. Available in all widths (also individual widths for aluminum frame ridges). May be assembled on the inside and outside flexure curves at both chain endings. Chain content is secured through hooped clamps that are available in different sizes. Material: Galvanized steel.

When ordering please indicate the type of chain and internal width.

Assembly

Disassembly

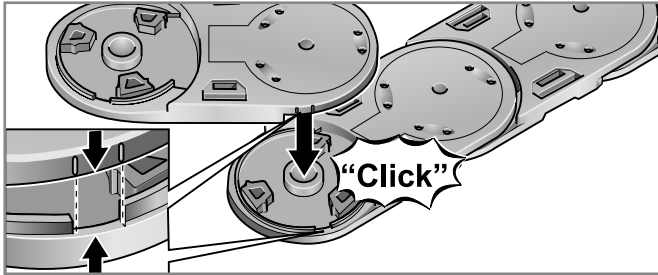

Step 1

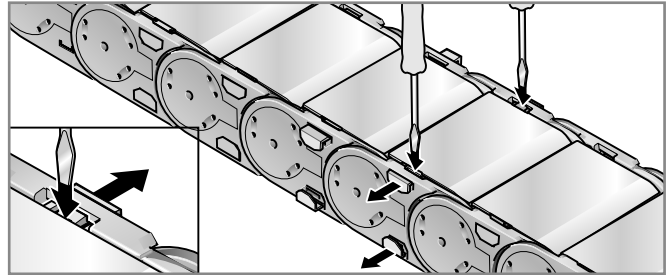

Step 1

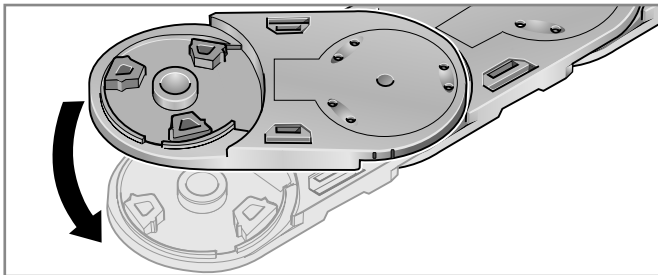

Step 2

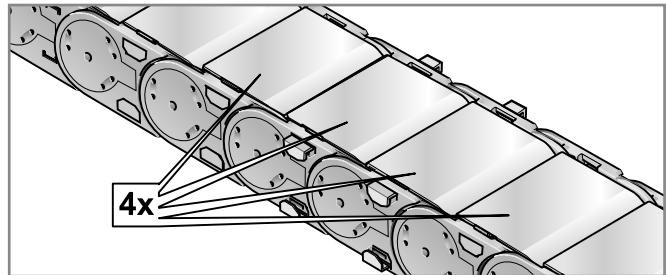

Step 2

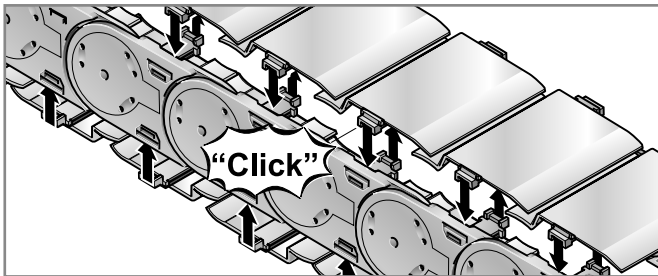

Step 3

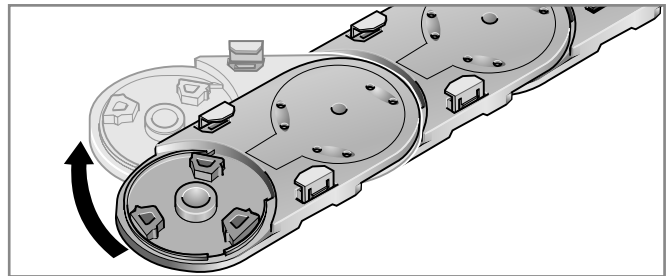

Step 3

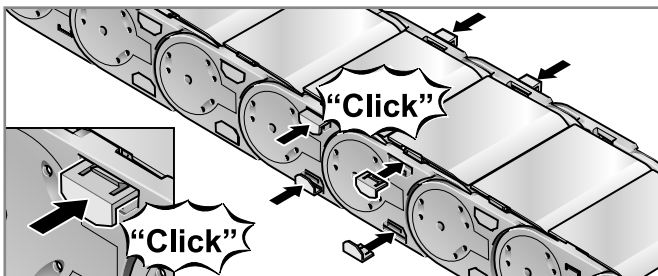

Step 4

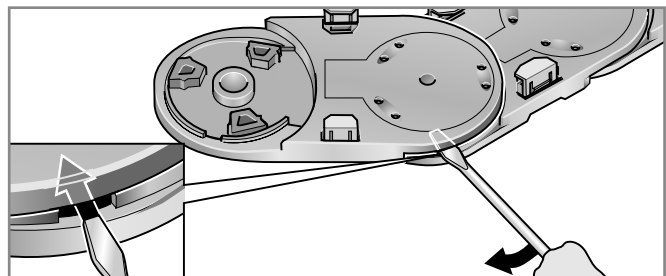

Step 4

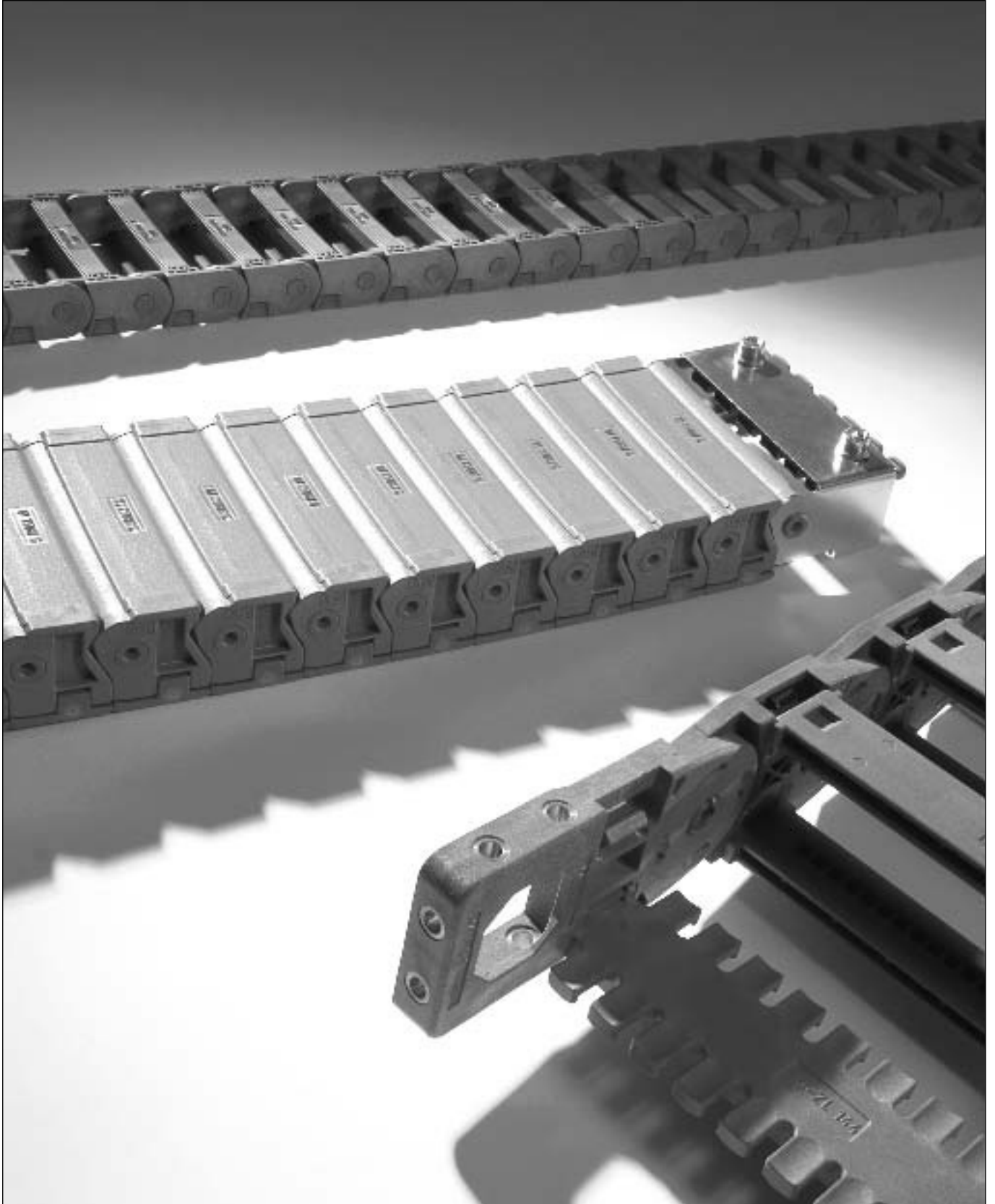

Cable drag chain systems

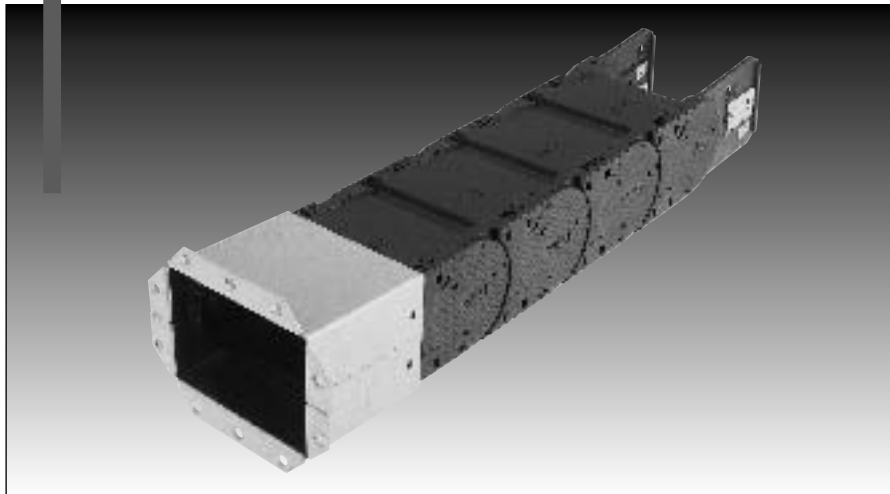

MultiLine

MP 65 G



MP 65 G - MultiLine

Order variants

Style (order code)							
Configuration (order code)							
Radius (order code) <small>The radii can be combined with any internal width</small>							
in inch							
Internal width (order code)							
in inch							
Outside width in inch							
MP65 084	4.65	3.31	084	7.87	200	0	
MP65 105	5.47	4.13	105	9.45	240	1	0
MP65 144	7.01	5.67	144	11.02	280	9	9
				13.78	350		

Order-Number:	0650			0			0
----------------------	-------------	--	--	----------	--	--	----------

Configuration:

- 0 PA crossbar every link; w/bias
- 1 PA crossbar every link; w/o bias
- 9 Custom version

Style:

- 0 Standard (PA/black)
- 9 Custom version

Sample order:

0650 084 200 0000

Internal width = 3.31 in (84 mm)
 Radius = 7.87 in (200 mm)
 Configuration = 0
 Style = 0

Ideal operating conditions:

- Compact dimensions with opening cover in inside/outside bend
- Quiet operation
- High stability
- Flexible internal separation

Alternative chain type:

- MP 66 open version

Features

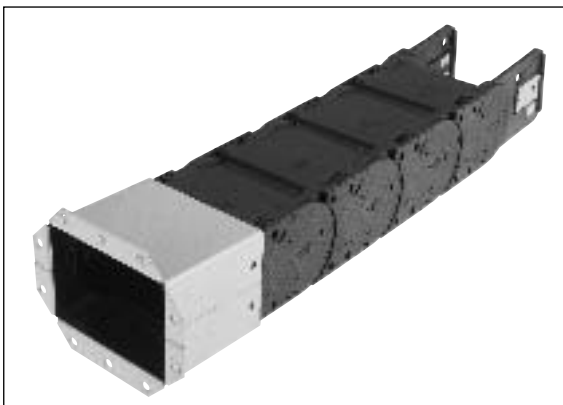

Chain bracket with variably positionable metal angle



Crossbar/cover can be removed from inside and outside flexure curve



Strain relief plate ZL



Flange connection for closed cable drag chains



Radii with or without bias (RV/RK)



Plug-in shelf system for reliable cable guidance

Technical data

Chain link dimensions (inch) (mm)

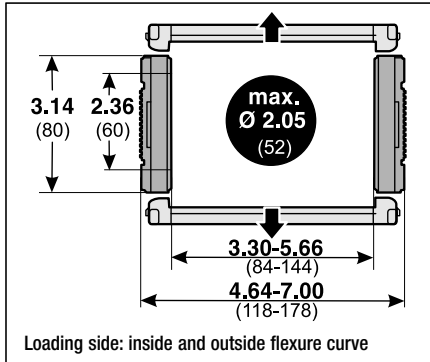

Material characteristics standard (PA/black)

Operating temperature: -22 to 248° F
 Gliding friction factor: 0.30
 Static friction factor: 0.45
 Fire classification: Based on UL94 HB

Other material properties on request

Technical specifications

Travel distance, gliding, L_g : 196.85 ft
 Travel distance, self-supporting, L_s : see diagram
 Travel distance, vertical, hanging, L_{vh} : 164.04 ft
 Travel distance, vertical, upright, L_{vu} : 16.40 ft
 Rotated 90°, self-supporting, L_{90r} : 6.56 ft
 Speed, gliding, V_g : 16.40 ft/s
 Speed, self-supporting, V_s : 49.21 ft/s
 Acceleration, gliding, a_g : 49.21 ft/s²
 Acceleration, self-supporting, a_s : 82.02 ft/s²

Self-supporting length

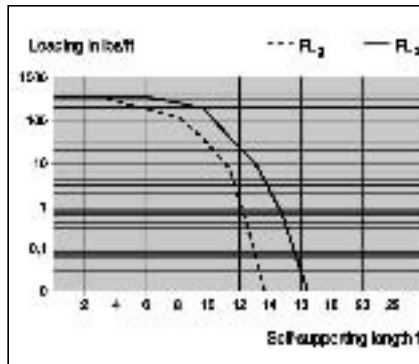
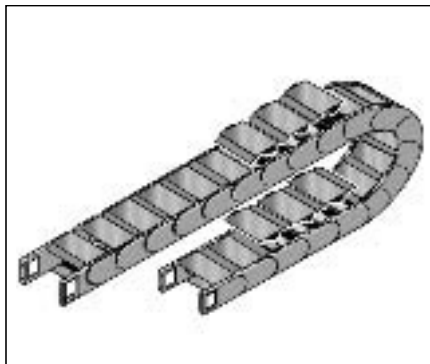

FL₁:
 Ideal installation situation for high stresses at the limit of the max. travel parameters. In this range the chain upper run is still biased, straight or has a max. sag of 0.39 – 1.97 in (10 – 50 mm) depending on the type of chain.

FL₂:
 Satisfactory installation position for many applications working in the lower to middle range of the max. travel parameters. Depending on the chain type, the sag of the chain upper run is >0.39 – 1.97 in (>10 – 50 mm) but certainly less than the max. sag.

If the sag is greater than FL₂, the arrangement is unsuitable and should be avoided. Please choose a more stable Murrplastik cable drag chain.

Determining the chain length

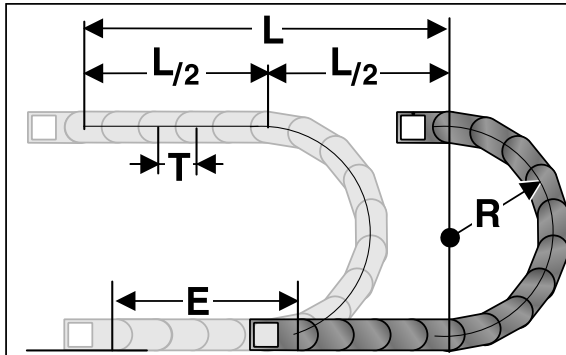

Determining the chain length

$$\text{Length} = \frac{L}{2} + \pi \times R + E$$

≈ 1 ft(m) chain = 3(11) links each 3.60 in (91.5 mm)

The fixed point of the cable drag chain should be connected in the middle of the travel distance. This arrangement gives the shortest connection between the fixed point and the moving point and thus the most efficient chain length.

Installation dimensions (in inch)

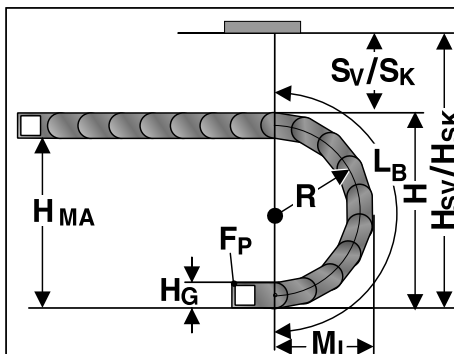

Radius R	7.87	9.45	11.02	13.78
Outside height of chain link (H_o)	3.15	3.15	3.15	3.15
Height of bend (H)	18.90	22.05	25.20	30.71
Height of moving end connection (H_{ma})	15.75	18.90	22.05	27.56
Safety margin with bias (S_v)	1.97	1.97	1.97	1.97
Installation height with bias (H_{sv})	20.87	24.02	27.17	32.68
Safety margin without bias (S_k)	0.59	0.59	0.59	0.59
Installation height without bias (H_{sk})	19.49	22.64	25.79	31.30
Arc projection (M_l)	13.07	14.65	16.22	18.98
Bend length (L_b)	33.27	38.23	43.15	51.81



Chain bracket

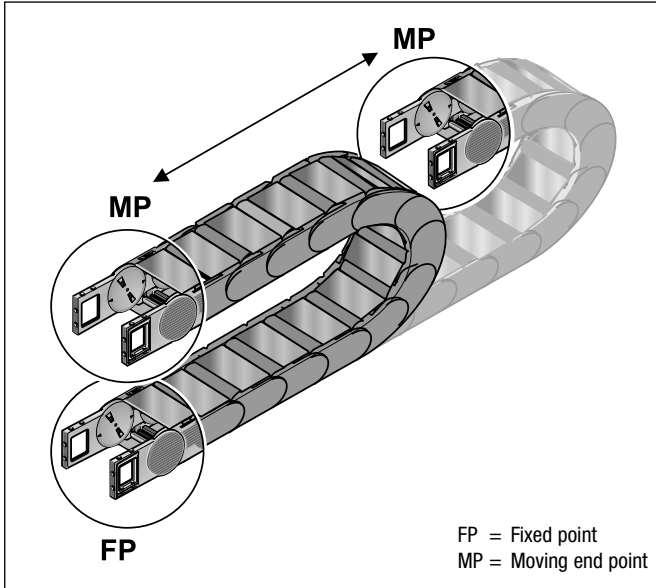

End brackets flange

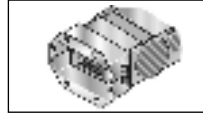

Chain bracket angle

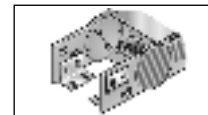
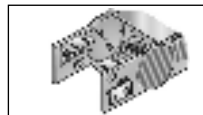
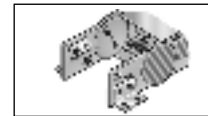
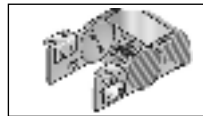

End brackets flange

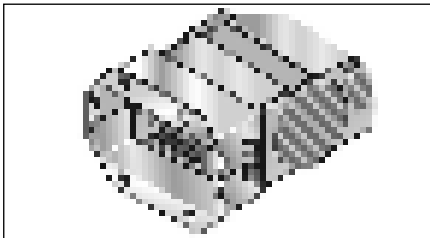

Type	Order no.	Material	Pack qty.
FL 082	0650000070	Sheet steel	1
FL 107	0650000072	Sheet steel	1
FL 142	0650000074	Sheet steel	1
FL 082	0650000080	Stainless steel 1.4301	1
FL 107	0650000082	Stainless steel 1.4301	1
FL 142	0650000084	Stainless steel 1.4301	1

A cable drag chain requires two chain brackets. The divisible flange connection has been specifically designed for commissioning and re-installation. This keeps the chain in the installed position.

Chain bracket angle

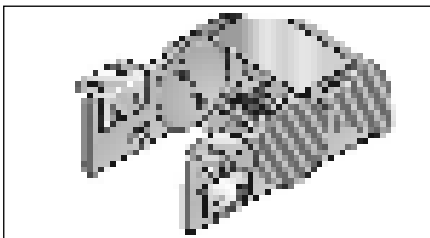

Type	Order no.	Material	Pack qty.
KA 66	0660000050	Sheet steel	1
KA 66	0660000060	Stainless steel 1.4301	1

There are several options regarding the chain bracket. The fixed-point bracket (inside/bottom) and the moving end bracket (inside/top) are supplied as standard. However, any other combination can be supplied upon request. The chain bracket is fastened at the end like a side link. This enables the chain to move right up to the bracket. Each chain requires two chain brackets. The brackets should be fastened with M6 screws.

End brackets flange

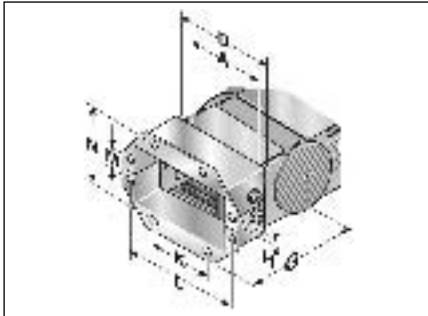

FL 082–142

Type	A inch	D inch	G inch	H Ø inch	K inch	L inch	M inch	N inch
FL 082	3.39	4.13	2.38	0.28	3.07	5.57	1.57	4.13
FL 107	4.02	4.76	2.38	0.28	3.94	6.44	1.57	4.13
FL 142	4.92	5.67	2.38	0.28	5.43	7.93	1.57	4.13

Chain bracket angle

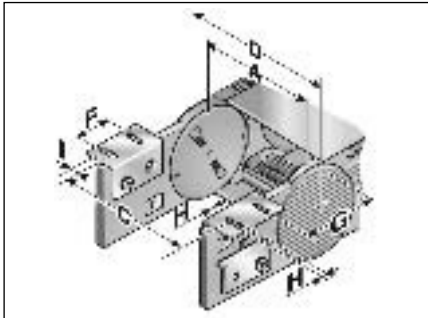

Bottom and top/outside

Type	A inch	C inch	D inch	F inch	G inch	H Ø inch	I inch
KA 66	3.31	5.31	4.63	1.77	1.99	0.35	0.39
KA 66	4.13	6.14	5.47	1.77	1.99	0.35	0.39
KA 66	5.67	7.68	6.99	1.77	1.99	0.35	0.39

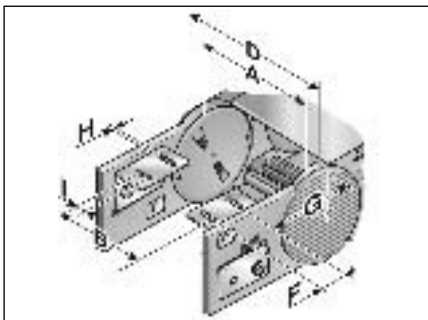

Bottom and top/inside

Type	A inch	B inch	D inch	F inch	G inch	H Ø inch	I inch
KA 66	3.31	2.64	4.63	1.77	1.99	0.35	0.39
KA 66	4.13	3.46	5.47	1.77	1.99	0.35	0.39
KA 66	5.67	5.00	6.99	1.77	1.99	0.35	0.39



MP 65 G - Accessories

Separator

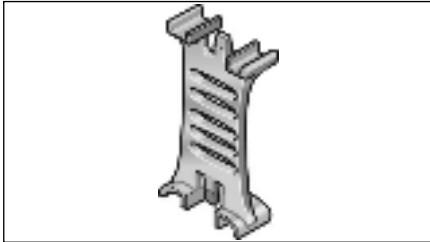

Separator

Type	Order no.	Designation	Lock grid spacing inch	Pack qty.
TV 66	066000009000	Separator	0.06	1

We recommend that separators be used if multiple round cables or conduits with differing diameters are to be installed. An offset configuration of the separators is advisable.

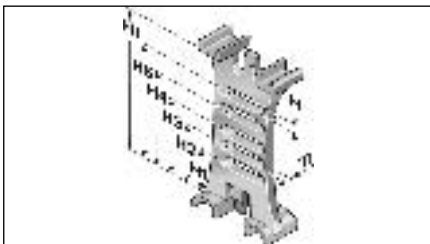

Separator

Type	T1 inch	H inch	H1 inch	H2 inch	H3 inch	H4 inch	H5 inch	H1 inch
TV 66	0.14	0.17	0.71	0.99	1.27	1.55	1.83	2.36

Shelving system

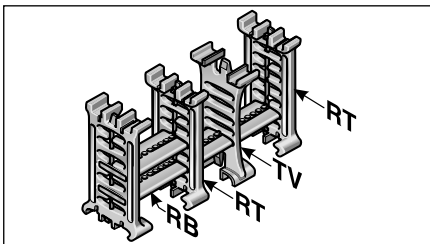

Shelving system

Type	Order no.	Designation	Width inch	Lock grid spacing inch	Pack qty.
RB 031	100000003100	RB 031 Shelf	1.22	0.06	1
RB 048	100000004800	RB 048 Shelf	1.89	0.06	1
RB 070	100000007000	RB 070 Shelf	2.76	0.06	1
RB 092	100000009200	RB 092 Shelf	3.62	0.06	1
RB 128	100000012800	RB 128 Shelf	5.04	0.06	1
RT 66	1000900100	RT 66 Shelf support incl. pin		0.06	1

In connection with at least two shelf supports (RT) the shelf becomes a shelving system. The additional levels prevent cables from criss-crossing and therefore destroying each other, while also avoiding excessive friction. The shelving system may be pre-assembled on request.

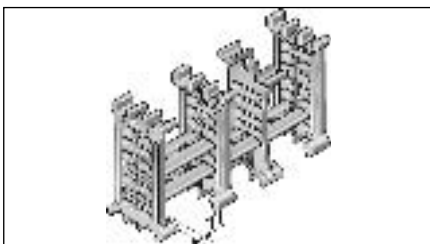

Shelving system

Type	T1 inch
RT 66	0.26

Assembly

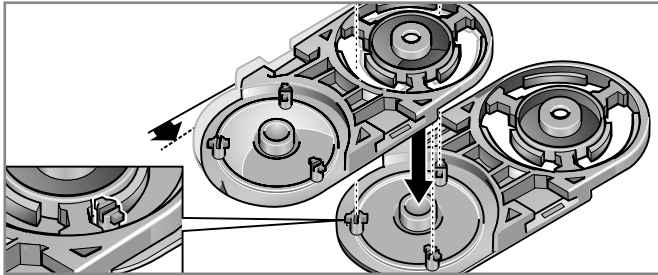

Step 1

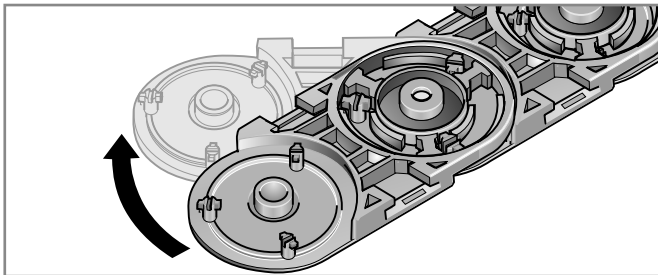

Step 2

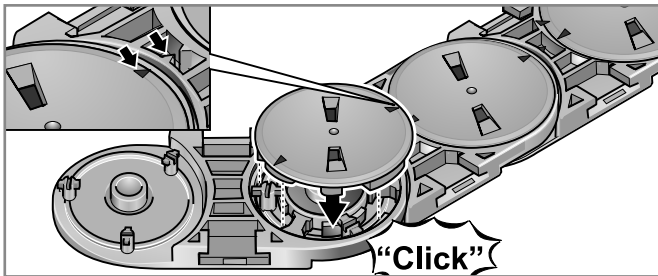

Step 3

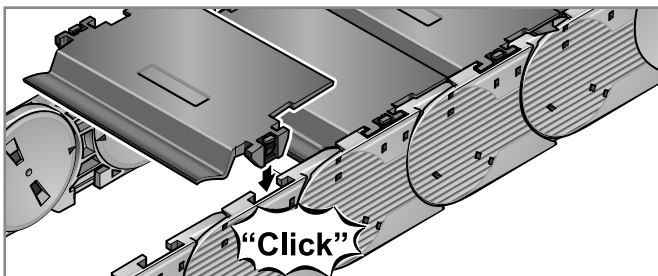

Step 4

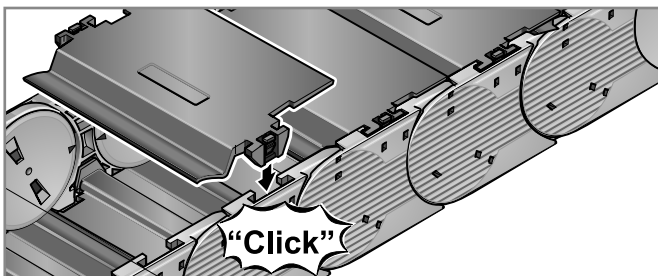

Step 5

Disassembly

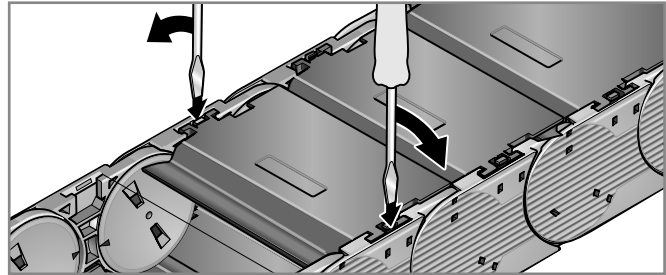

Step 1

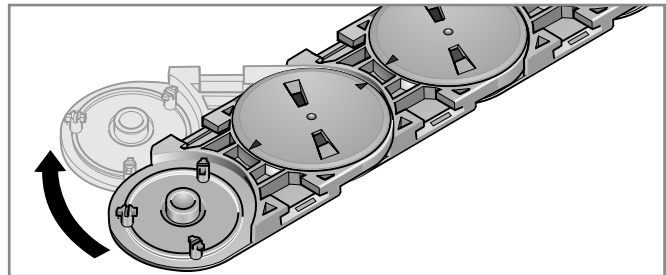

Step 2

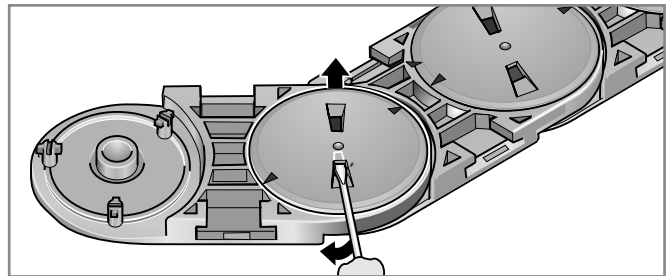

Step 3

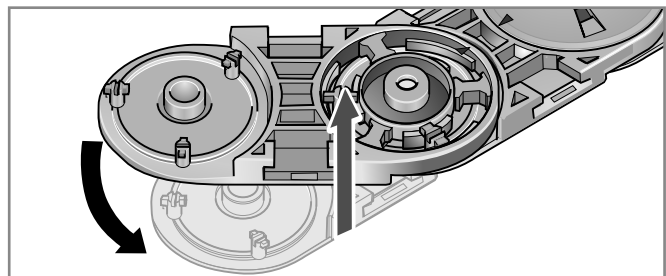

Step 4



Cable drag chain systems

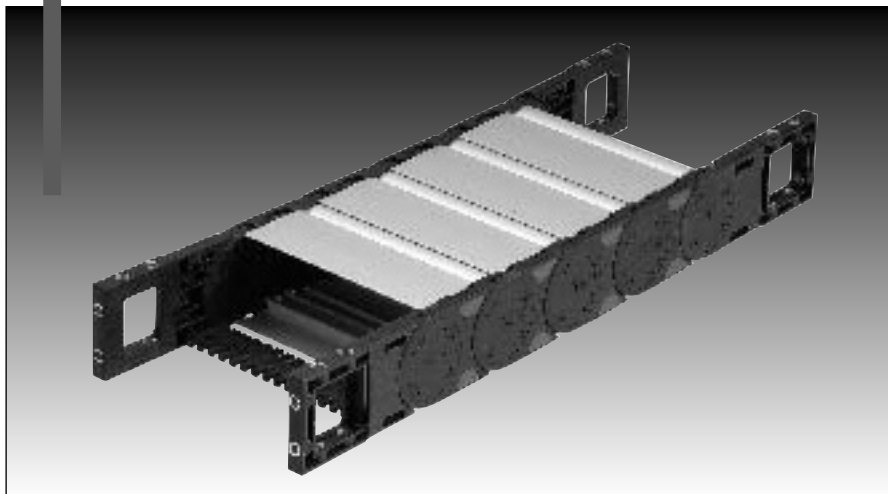

ClosedLine

MP 62.3 G



MP 62.3 G - ClosedLine

Order variants

Style (order code)									
Configuration (order code) * = standard									
Radius (order code) <small>The radii can be combined with any internal width</small>									
in inch									
Internal width (order code) <small># also available with plastic cover</small>									
in inch									
Outside width									
in inch									
MP62.3G 118	5.91	4.65	118#						
MP62.3G 143	6.89	5.63	143#						
MP62.3G 168	7.87	6.61	168						
MP62.3G 193	8.86	7.60	193#						
MP62.3G 218	9.84	8.58	218						
MP62.3G 243	10.38	9.57	243#						
MP62.3G 268	11.81	10.55	268						
MP62.3G 293	12.80	11.54	293#						
MP62.3G 318	13.78	12.52	318	7.87	200				
MP62.3G 343	14.76	13.50	343#	9.84	250				
MP62.3G 368	15.75	14.49	368	11.81	300				
MP62.3G 418	17.72	16.46	418#	13.78	350			0	
MP62.3G xxx	inside + 1.26	>4.65 -23.62	Alu	15.75	400			1	0
				19.69	500			4*	9
								5*	

Order-Number:

Configuration:

- 0 PA crossbar every link; w/bias
- 1 PA crossbar every link; w/o bias
- 4* AL crossbar every link; w/bias
- 5* AL crossbar every link; w/o bias

Style:

- 0 Standard (PA/black)
- 9 Custom version

Sample order:

0623 118# 200 0000

Internal width = 4.65 in (118 mm)
 Radius = 7.87 in (200 mm)
 Configuration = 0
 Style = 0

Ideal operating conditions:

- Extremely high accelerations
- Extremely high speeds
- Very high additional loads
- Long travel distances
- Extreme self-supporting lengths

Alternative chain type:

- MP 62.2 open series
- MP 65G for easier use

Note:

- Plastic cover available starting 1st Quarter 2008

Features

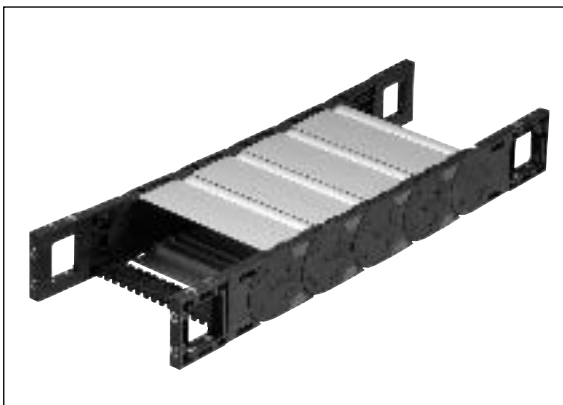

- Chain bracket, can be fastened on three sides
- Chain bracket with variably positionable metal angle
- Crossbar/cover can be removed from inside and outside flexure curve
- Side links with CLICK lock for easy opening
- Radii with or without bias (RK/RV)
- Crossbar strain relief can be integrated into chain bracket
- Aluminum frame bridges with integrated lock grid in variable lengths
- C-profile rail can be integrated into chain bracket
- Integrable separator for cable separation
- Foldable shelf system for reliable cable guidance

Technical data

Chain link dimensions (inch) (mm)

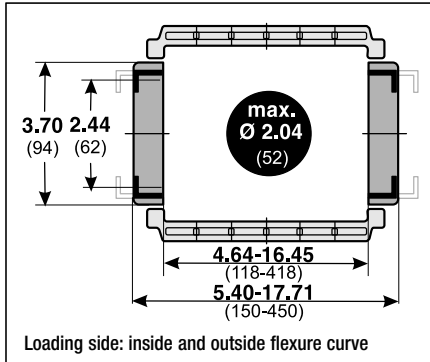

Material characteristics standard (PA/black)

Operating temperature: -22 to 248° F
 Gliding friction factor: 0.30
 Static friction factor: 0.45
 Fire classification: Based on UL94 HB

Other material properties on request

Technical specifications

Travel distance, gliding, L_g : 492.13 ft
 Travel distance, self-supporting, L_s : see diagram
 Travel distance, vertical, hanging, L_{vh} : 393.70 ft
 Travel distance, vertical, upright, L_{vu} : 19.69 ft
 Rotated 90°, self-supporting, L_{90r} : 6.56 ft
 Speed, gliding, V_g : 16.40 ft/s
 Speed, self-supporting, V_s : 65.62 ft/s
 Acceleration, gliding, a_g : 82.02 ft/s²
 Acceleration, self-supporting, a_s : 131.23 ft/s²

Self-supporting length

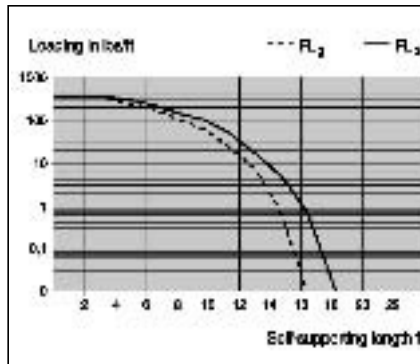
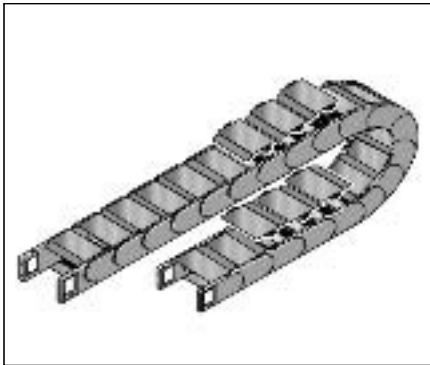

FL₂:
 Ideal installation situation for high stresses at the limit of the max. travel parameters. In this range the chain upper run is still biased, straight or has a max. sag of 0.39 – 1.97 in (10 – 50 mm) depending on the type of chain.

FL₃:
 Satisfactory installation position for many applications working in the lower to middle range of the max. travel parameters. Depending on the chain type, the sag of the chain upper run is >0.39 – 1.97 in (>10 – 50 mm) but certainly less than the max. sag.

If the sag is greater than FL₃, the arrangement is unsuitable and should be avoided. Please choose a more stable Murrplastik cable drag chain.

Determining the chain length

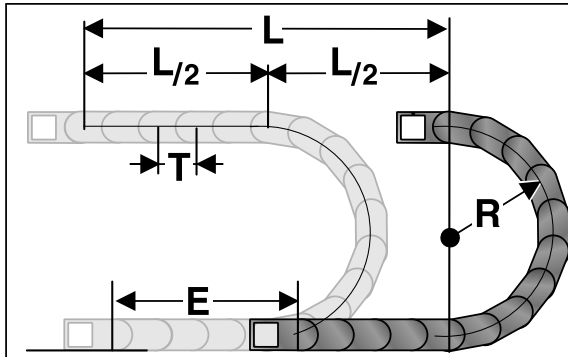

Determining the chain length

$$\text{Length} = \frac{L}{2} + \pi \times R + E$$

$$\approx 1 \text{ ft(m) chain} = 3(10) \text{ links each } 3.94 \text{ in (100 mm)}$$

The fixed point of the cable drag chain should be connected in the middle of the travel distance. This arrangement gives the shortest connection between the fixed point and the moving point and thus the most efficient chain length.

Installation dimensions (in inch)

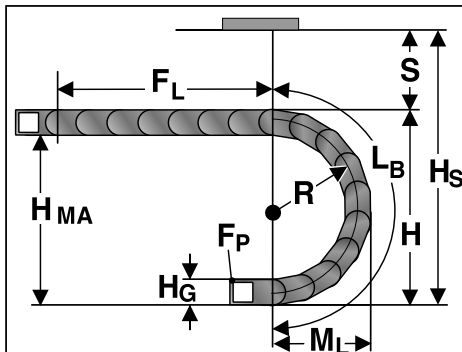

Radius R	7.87	9.84	11.81	13.78	15.75	19.69
Outside height of chain link (H_o)	3.70	3.70	3.70	3.70	3.70	3.70
Height of bend (H)	20.63	24.57	28.50	32.44	36.38	44.25
Height of moving end connection (H_{ma})	16.93	20.87	24.80	28.74	32.68	40.55
Safety margin with bias (S_v)	1.97	1.97	1.97	1.97	1.97	1.97
Installation height with bias (H_{sv})	22.60	26.54	30.47	34.41	38.35	45.16
Safety margin without bias (S_k)	0.79	0.79	0.79	0.79	0.79	0.79
Installation height without bias (H_{sk})	21.12	25.35	29.29	33.23	37.17	45.04
Arc projection (M_l)	14.25	16.22	18.19	20.16	22.13	26.06
Bend length (L_b)	36.34	42.52	48.70	54.88	61.06	73.43



MP 62.3 G - ClosedLine

Chain bracket

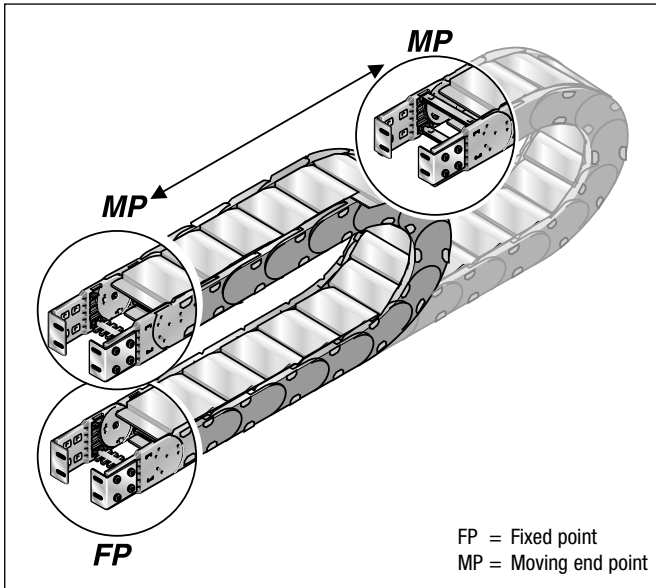

Flexible chain bracket

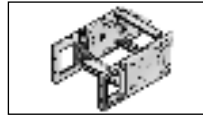

Chain bracket angle

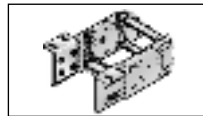

Top/Outside

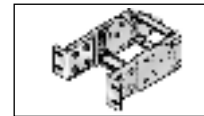

Front/Outside

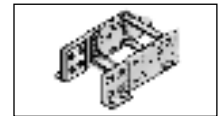

Bottom/Outside

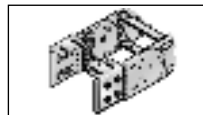

Top/Inside

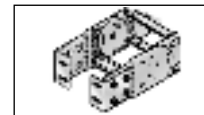

Up / Inside

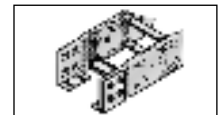

Bottom/Inside

Flexible chain bracket

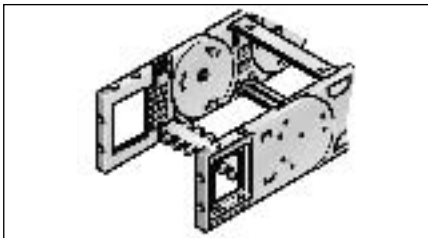

Type	Order no.	Version	Pack qty.
KA 62.1-FB	0620000056	with bushing	1
KA 62.1-FB	0620000057	with bushing	1
KA 62.1-FG	0620000058	with thread	1
KA 62.1-FG	0620000059	with thread	1

This chain bracket offers universal connection options (top, bottom and front) and is attached to the ends of the chain like a side link. This allows the chain to move right up to the bracket. Each chain requires one male and one female bracket. Use M8 screws for connecting. Extrusion-coated metal bushings with either a through-hole (-FB) or a threaded hole (-FG) ensure the permanent, high-strength transmission of even extreme forces onto the cable drag chain.

Chain bracket angle

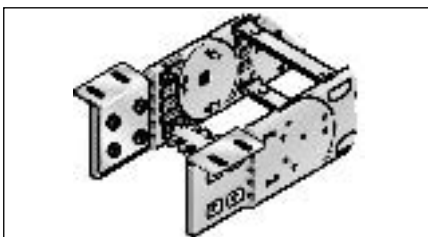

Type	Order no.	Pack qty.
KA 62 Female end	0621000050	1
KA 62 Male end	0621000051	1

There are several options regarding the chain bracket. The fixed-point bracket (inside/bottom) and the moving end bracket (inside/top) are supplied as standard. However, any other combination can be supplied upon request. The chain bracket is fastened at the end like a side link. This enables the chain to move right up to the bracket. Each chain requires one male and one female bracket. Fasten the connections with M8 screws.

Flexible chain bracket

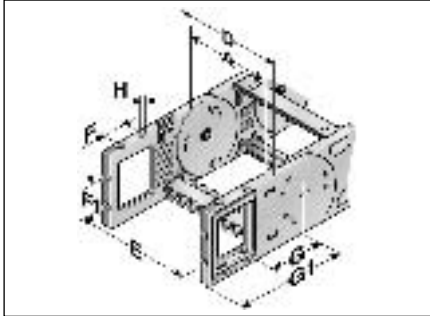

Flexible with through-hole

Type	A inch	D inch	E inch	F inch	F1 inch	G inch	G1 inch	H Ø inch
KA62-FB	4.65	5.91	5.31	1.38	1.77	4.21	6.75	0.33
KA62-FB	5.63	6.89	6.30	1.38	1.77	4.21	6.75	0.33
KA62-FB	6.61	7.87	7.28	1.38	1.77	4.21	6.75	0.33
KA62-FB	7.60	8.86	8.27	1.38	1.77	4.21	6.75	0.33
KA62-FB	8.58	9.84	9.25	1.38	1.77	4.21	6.75	0.33
KA62-FB	9.57	10.83	10.24	1.38	1.77	4.21	6.75	0.33
KA62-FB	10.55	11.81	11.22	1.38	1.77	4.21	6.75	0.33
KA62-FB	11.54	12.80	12.20	1.38	1.77	4.21	6.75	0.33
KA62-FB	12.52	13.78	13.19	1.38	1.77	4.21	6.75	0.33
KA62-FB	13.50	14.76	14.17	1.38	1.77	4.21	6.75	0.33
KA62-FB	14.49	15.75	15.16	1.38	1.77	4.21	6.75	0.33
KA62-FB	16.46	17.72	17.13	1.38	1.77	4.21	6.75	0.33
KA62-FB	variable	A+1.26	A+0.67	1.38	1.77	4.21	6.75	0.33

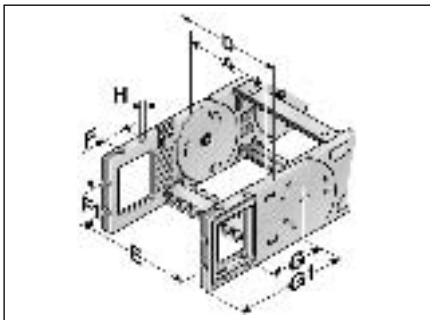

Flexible with threaded bushing

Type	A inch	D inch	E inch	F inch	F1 inch	G inch	G1 inch	H
KA62-FG	4.65	5.91	5.31	1.38	1.77	4.21	6.75	M8
KA62-FG	5.63	6.89	6.30	1.38	1.77	4.21	6.75	M8
KA62-FG	6.61	7.87	7.28	1.38	1.77	4.21	6.75	M8
KA62-FG	7.60	8.86	8.27	1.38	1.77	4.21	6.75	M8
KA62-FG	8.58	9.84	9.25	1.38	1.77	4.21	6.75	M8
KA62-FG	9.57	10.83	10.24	1.38	1.77	4.21	6.75	M8
KA62-FG	10.55	11.81	11.22	1.38	1.77	4.21	6.75	M8
KA62-FG	11.54	12.80	12.20	1.38	1.77	4.21	6.75	M8
KA62-FG	12.52	13.78	13.19	1.38	1.77	4.21	6.75	M8
KA62-FG	13.50	14.76	14.17	1.38	1.77	4.21	6.75	M8
KA62-FG	14.49	15.75	15.16	1.38	1.77	4.21	6.75	M8
KA62-FG	16.46	17.72	17.13	1.38	1.77	4.21	6.75	M8
KA62-FG	variable	A+1.26	A+0.67	1.38	1.77	4.21	6.75	M8

Chain bracket angle

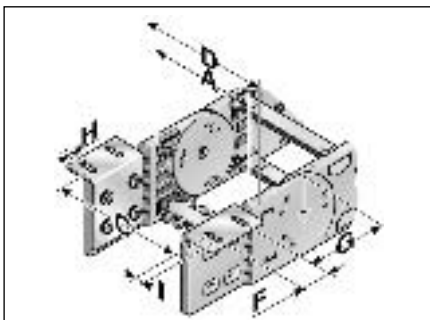

Bottom and top/outside

Type	A inch	C inch	D inch	F inch	G inch	H Ø inch	I inch
KA 62	4.65	6.38	5.91	1.77	4.02	0.35	0.59
KA 62	5.63	7.36	6.89	1.77	4.02	0.35	0.59
KA 62	6.61	8.35	7.87	1.77	4.02	0.35	0.59
KA 62	7.60	9.33	8.86	1.77	4.02	0.35	0.59
KA 62	8.58	10.31	9.84	1.77	4.02	0.35	0.59
KA 62	9.57	11.30	10.83	1.77	4.02	0.35	0.59
KA 62	10.55	12.28	11.81	1.77	4.02	0.35	0.59
KA 62	11.54	13.27	12.80	1.77	4.02	0.35	0.59
KA 62	12.52	14.25	13.78	1.77	4.02	0.35	0.59
KA 62	13.50	15.24	14.76	1.77	4.02	0.35	0.59
KA 62	14.49	16.22	15.75	1.77	4.02	0.35	0.59
KA 62	16.46	18.19	17.72	1.77	4.02	0.35	0.59
KA 62	variable	A+1.73	A+1.26	1.77	4.02	0.35	0.59



MP 62.3 G - ClosedLine

Chain bracket angle

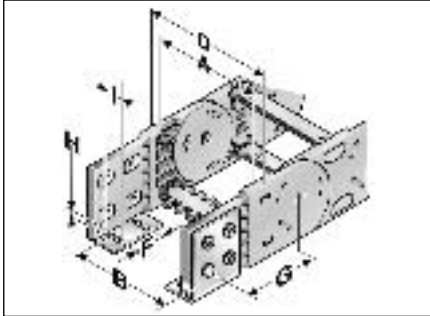

Bottom and top/inside

Type	A inch	C inch	D inch	F inch	G inch	H Ø inch	I inch
KA 62	4.65	4.17	5.91	1.77	4.02	0.35	0.59
KA 62	5.63	5.16	6.89	1.77	4.02	0.35	0.59
KA 62	6.61	6.14	7.87	1.77	4.02	0.35	0.59
KA 62	7.60	7.13	8.86	1.77	4.02	0.35	0.59
KA 62	8.58	8.11	9.84	1.77	4.02	0.35	0.59
KA 62	9.57	9.09	10.83	1.77	4.02	0.35	0.59
KA 62	10.55	10.08	11.81	1.77	4.02	0.35	0.59
KA 62	11.54	11.06	12.80	1.77	4.02	0.35	0.59
KA 62	12.52	12.13	13.78	1.77	4.02	0.35	0.59
KA 62	13.50	13.03	14.76	1.77	4.02	0.35	0.59
KA 62	14.49	14.02	15.75	1.77	4.02	0.35	0.59
KA 62	16.46	15.98	17.72	1.77	4.02	0.35	0.59
KA 62	variable	A-0.47	A+1.26	1.77	4.02	0.35	0.59

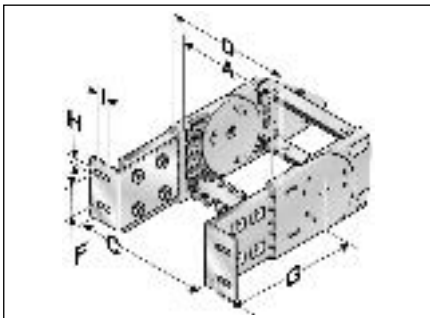

Front/Outside

Type	A inch	C inch	D inch	F inch	G inch	H Ø inch	I inch
KA 62	4.65	6.38	5.91	1.77	6.75	0.35	0.59
KA 62	5.63	7.36	6.89	1.77	6.75	0.35	0.59
KA 62	6.61	8.35	7.87	1.77	6.75	0.35	0.59
KA 62	7.60	9.33	8.86	1.77	6.75	0.35	0.59
KA 62	8.58	10.31	9.84	1.77	6.75	0.35	0.59
KA 62	9.57	11.30	10.83	1.77	6.75	0.35	0.59
KA 62	10.55	12.28	11.81	1.77	6.75	0.35	0.59
KA 62	11.54	13.27	12.80	1.77	6.75	0.35	0.59
KA 62	12.52	14.25	13.78	1.77	6.75	0.35	0.59
KA 62	13.50	15.24	14.76	1.77	6.75	0.35	0.59
KA 62	14.49	16.22	15.75	1.77	6.75	0.35	0.59
KA 62	16.46	18.19	17.72	1.77	6.75	0.35	0.59
KA 62	variable	A+1.73	A+1.26	1.77	6.75	0.35	0.59

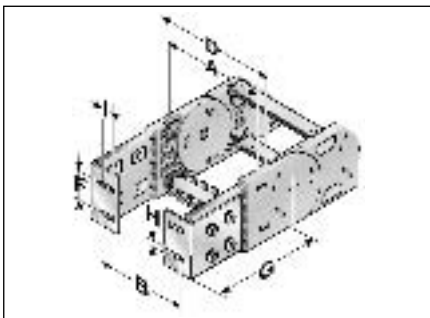

Front/Inside

Type	A inch	C inch	D inch	F inch	G inch	H Ø inch	I inch
KA 62	4.65	4.17	5.91	1.77	6.75	0.35	0.59
KA 62	5.63	5.16	6.89	1.77	6.75	0.35	0.59
KA 62	6.61	6.14	7.87	1.77	6.75	0.35	0.59
KA 62	7.60	7.13	8.86	1.77	6.75	0.35	0.59
KA 62	8.58	8.11	9.84	1.77	6.75	0.35	0.59
KA 62	9.57	9.09	10.83	1.77	6.75	0.35	0.59
KA 62	10.55	10.08	11.81	1.77	6.75	0.35	0.59
KA 62	11.54	11.06	12.80	1.77	6.75	0.35	0.59
KA 62	12.52	12.13	13.78	1.77	6.75	0.35	0.59
KA 62	13.50	13.03	14.76	1.77	6.75	0.35	0.59
KA 62	14.49	14.02	15.75	1.77	6.75	0.35	0.59
KA 62	16.46	15.98	17.72	1.77	6.75	0.35	0.59
KA 62	variable	A-0.47	A+1.26	1.77	6.75	0.35	0.59

Separator

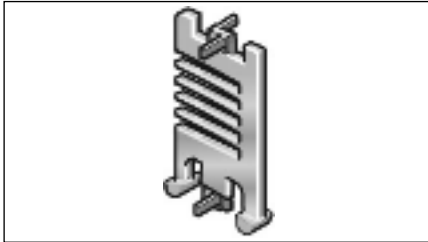

Separator

Type	Order no.	Designation	Lock grid spacing inch	Pack qty.
TR 62	062000009200	Separator	0.20	1

We recommend that separators be used if multiple round cables or conduits with differing diameters are to be installed. An offset configuration of the separators is advisable.

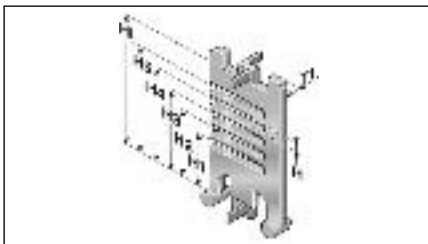

Separator

Type	Tl inch	H inch	H1 inch	H2 inch	H3 inch	H4 inch	H5 inch	Hl inch
TR 62	0.14	0.22	0.58	0.91	1.24	1.56	1.89	2.44

Shelving system

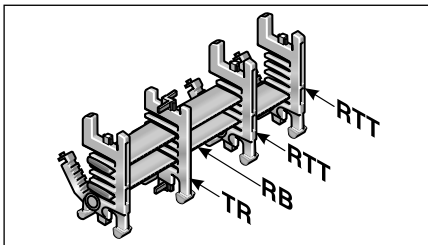

Shelving system

Type	Order no.	Designation	Width inch	Lock grid spacing inch	Pack qty.
RB 056-7	100000005600	RB 056-7 Shelf	2.20	0.20	1
RB 066-7	100000006600	RB 066-7 Shelf	2.60	0.20	1
RB 081-7	100000008100	RB 081-7 Shelf	3.19	0.20	1
RB 106-7	100000010600	RB 106-7 Shelf	4.17	0.20	1
RB 116-7	100000011600	RB 116-7 Shelf	4.57	0.20	1
RB 166-7	100000016600	RB 166-7 Shelf	6.54	0.20	1
RB 216-7	100000021600	RB 216-7 Shelf	8.50	0.20	1
RTT 62	100090622000	RTT 62 Shelf support, divisible		0.20	1

In connection with at least two shelf supports (RTT) the shelf becomes a shelving system. The additional levels prevent cables from criss-crossing and therefore destroying each other, while also avoiding excessive friction. The shelving system may be pre-assembled on request.

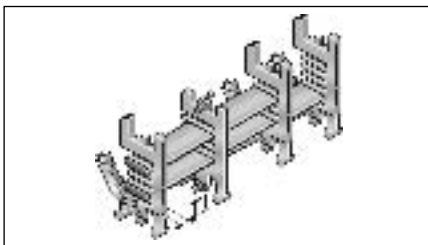

Shelving system

Type	Tl inch
RTT 62	0.31



MP 62.3 G - Accessories

Chain bracket cover D6

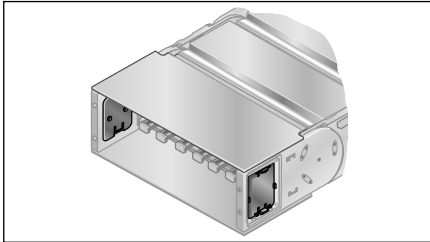

Side link cover

Type	Order no.	Pack qty.
Cover D6 KA 62.1-FB/FG	0623888002	2

Self-locking covers close the side mounting window on the flexible chain bracket (KA-FB/FG).

Chain bracket cover

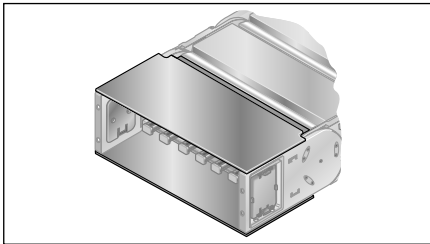

Covers for the flexible chain bracket (KA-FB/FG) allow for a closed variant up to the chain's end.

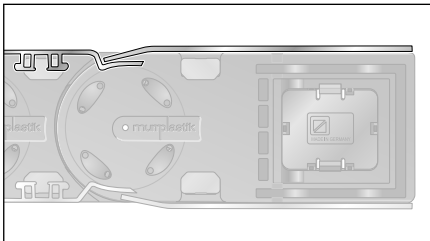

outside flexure curve

Type	Order no.	Inside width inch	Material	Pack qty.
Cover KA 62 FB/FG AB 118 1-2	0621118059	4.65	Anodized aluminum	1
Cover KA 62 FB/FG AB 143 1-2	0621143059	5.63	Anodized aluminum	1
Cover KA 62 FB/FG AB 168 1-2	0621168059	6.61	Anodized aluminum	1
Cover KA 62 FB/FG AB 193 1-2	0621193059	7.60	Anodized aluminum	1
Cover KA 62 FB/FG AB 218 1-2	0621218059	8.58	Anodized aluminum	1
Cover KA 62 FB/FG AB 243 1-2	0621243059	9.57	Anodized aluminum	1
Cover KA 62 FB/FG AB 268 1-2	0621268059	10.55	Anodized aluminum	1
Cover KA 62 FB/FG AB 293 1-2	0621293059	11.54	Anodized aluminum	1
Cover KA 62 FB/FG AB 318 1-2	0621318059	12.52	Anodized aluminum	1
Cover KA 62 FB/FG AB 343 1-2	0621343059	13.50	Anodized aluminum	1
Cover KA 62 FB/FG AB 368 1-2	0621368059	14.49	Anodized aluminum	1
Cover KA 62 FB/FG AB 418 1-2	0621418059	16.46	Anodized aluminum	1

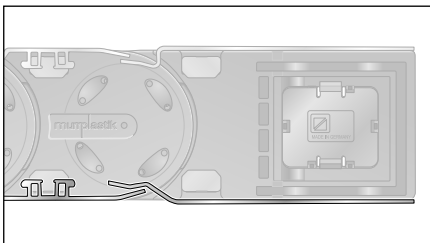

outside flexure curve

Type	Order no.	Inside width inch	Material	Pack qty.
Cover KA 62 FB/FG AB 118 2-2	0621118060	4.65	Anodized aluminum	1
Cover KA 62 FB/FG AB 143 2-2	0621143060	5.63	Anodized aluminum	1
Cover KA 62 FB/FG AB 168 2-2	0621168060	6.61	Anodized aluminum	1
Cover KA 62 FB/FG AB 193 2-2	0621193060	7.60	Anodized aluminum	1
Cover KA 62 FB/FG AB 218 2-2	0621218060	8.58	Anodized aluminum	1
Cover KA 62 FB/FG AB 243 2-2	0621243060	9.57	Anodized aluminum	1
Cover KA 62 FB/FG AB 268 2-2	0621268060	10.55	Anodized aluminum	1
Cover KA 62 FB/FG AB 293 2-2	0621293060	11.54	Anodized aluminum	1
Cover KA 62 FB/FG AB 318 2-2	0621318060	12.52	Anodized aluminum	1
Cover KA 62 FB/FG AB 343 2-2	0621343060	13.50	Anodized aluminum	1
Cover KA 62 FB/FG AB 368 2-2	0621368060	14.49	Anodized aluminum	1
Cover KA 62 FB/FG AB 418 2-2	0621418060	16.46	Anodized aluminum	1

Chain bracket cover

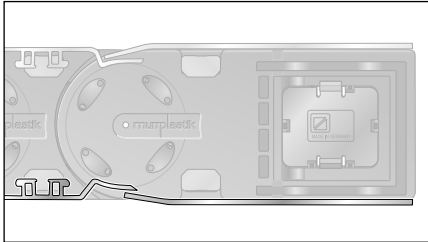

inside flexure curve

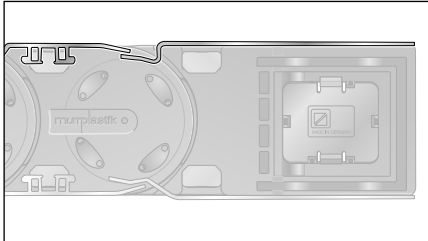

inside flexure curve

Type	Order no.	Inside width inch	Material	Pack qty.
Cover KA 62 FB/FG IB 118 1-2	0621118057	4.65	Anodized aluminum	1
Cover KA 62 FB/FG IB 143 1-2	0621143057	5.63	Anodized aluminum	1
Cover KA 62 FB/FG IB 168 1-2	0621168057	6.61	Anodized aluminum	1
Cover KA 62 FB/FG IB 193 1-2	0621193057	7.60	Anodized aluminum	1
Cover KA 62 FB/FG IB 218 1-2	0621218057	8.58	Anodized aluminum	1
Cover KA 62 FB/FG IB 243 1-2	0621243057	9.57	Anodized aluminum	1
Cover KA 62 FB/FG IB 268 1-2	0621268057	10.55	Anodized aluminum	1
Cover KA 62 FB/FG IB 293 1-2	0621293057	11.54	Anodized aluminum	1
Cover KA 62 FB/FG IB 318 1-2	0621318057	12.52	Anodized aluminum	1
Cover KA 62 FB/FG IB 343 1-2	0621343057	13.50	Anodized aluminum	1
Cover KA 62 FB/FG IB 368 1-2	0621368057	14.49	Anodized aluminum	1
Cover KA 62 FB/FG IB 418 1-2	0621418057	16.46	Anodized aluminum	1

Type	Order no.	Inside width inch	Material	Pack qty.
Cover KA 62 FB/FG IB 118 2-2	0621118058	4.65	Anodized aluminum	1
Cover KA 62 FB/FG IB 143 2-2	0621143058	5.63	Anodized aluminum	1
Cover KA 62 FB/FG IB 168 2-2	0621168058	6.61	Anodized aluminum	1
Cover KA 62 FB/FG IB 193 2-2	0621193058	7.60	Anodized aluminum	1
Cover KA 62 FB/FG IB 218 2-2	0621218058	8.58	Anodized aluminum	1
Cover KA 62 FB/FG IB 243 2-2	0621243058	9.57	Anodized aluminum	1
Cover KA 62 FB/FG IB 268 2-2	0621268058	10.55	Anodized aluminum	1
Cover KA 62 FB/FG IB 293 2-2	0621293058	11.54	Anodized aluminum	1
Cover KA 62 FB/FG IB 318 2-2	0621318058	12.52	Anodized aluminum	1
Cover KA 62 FB/FG IB 343 2-2	0621343058	13.50	Anodized aluminum	1
Cover KA 62 FB/FG IB 368 2-2	0621368058	14.49	Anodized aluminum	1
Cover KA 62 FB/FG IB 418 2-2	0621418058	16.46	Anodized aluminum	1

Crossbar strain relief plate RS-ZL

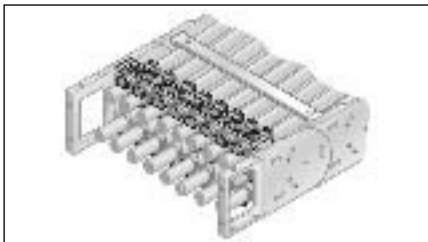

Crossbar strain relief plate RS-ZL

Type	Order no.	For internal width inch	Pack qty.
RS-ZL 118-7	072011800010	4.65	1
RS-ZL 143-7	072014300010	5.63	1
RS-ZL 168-7	072016800010	6.61	1
RS-ZL 193-7	072019300010	7.60	1
RS-ZL 218-7	072021800010	8.58	1
RS-ZL 243-7	072024300010	9.57	1

Fixed integrated frame bridge strain relief plates in the chain brackets. Accommodated to all widths of the frame ridges, up to 9.57 in (243 mm) in size. May be assembled on the inside and outside flexure curves at both chain endings.



MP 62.3 G - Accessories

Strain relief type BAK

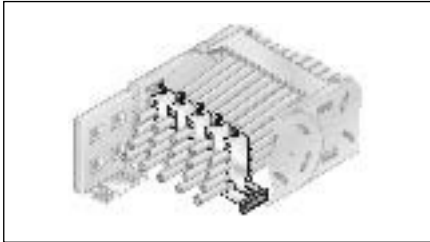

Strain relief with hooped clamp

Type	Order no.	Designation	Ø inch	Number of seats	Pack qty.
C-rail	81661610	C-profile rail			1
BA 12	81661036	BA 12 Hooped clamp	0.35–0.47	1	1
BAK 14	81661002	BAK 14 Hooped clamp	0.24–0.55	1	1
BAK 18	81661004	BAK 18 Hooped clamp	0.55–0.71	1	1
BAK 22	81661006	BAK 22 Hooped clamp	0.71–0.87	1	1
BAK 26	81661008	BAK 26 Hooped clamp	0.87–1.02	1	1
BAK 30	81661010	BAK 30 Hooped clamp	1.02–1.18	1	1
BAK 34	81661000	BAK 34 Hooped clamp	1.18–1.34	1	1
BAK 38	81661044	BAK 38 Hooped clamp	1.34–1.50	1	1
BAK 42	81661032	BAK 42 Hooped clamp	1.50–1.65	1	1
BAK 46	81661050	BAK 46 Hooped clamp	1.65–1.81	1	1
BA 12/2	81661038	BA 12/2 Hooped clamp	0.35–0.47	2	1
BAK 14/2	81661012	BAK 14/2 Hooped clamp	0.39–0.55	2	1
BAK 18/2	81661014	BAK 18/2 Hooped clamp	0.55–0.71	2	1
BAK 22/2	81661016	BAK 22/2 Hooped clamp	0.71–0.87	2	1
BAK 26/2	81661018	BAK 26/2 Hooped clamp	0.87–1.02	2	1
BAK 30/2	81661048	BAK 30/2 Hooped clamp	1.02–1.18	2	1
BAK 34/2	81661044	BAK 34/2 Hooped clamp	1.18–1.34	2	1
BAK 38/2	81661046	BAK 38/2 Hooped clamp	1.34–1.50	2	1
BAK 42/2	81661034	BAK 42/2 Hooped clamp	1.50–1.65	2	1
BAK 12/3	81661020	BAK 12/3 Hooped clamp	0.35–0.47	3	1
BAK 14/3	81661022	BAK 14/3 Hooped clamp	0.47–0.55	3	1
BAK 16/3	81661024	BAK 16/3 Hooped clamp	0.55–0.63	3	1
BAK 18/3	81661026	BAK 18/3 Hooped clamp	0.63–0.71	3	1
BAK 20/3	81661028	BAK 20/3 Hooped clamp	0.71–0.79	3	1
BAK 22/3	81661030	BAK 22/3 Hooped clamp	0.79–0.87	3	1

Fixed integrated strain relief in the chain connections. Available in all widths (also individual widths for aluminum frame ridges). May be assembled on the inside and outside flexure curves at both chain endings. Chain content is secured through hooped clamps that are available in different sizes. Material: Galvanized steel.

When ordering please indicate the type of chain and internal width.

Assembly

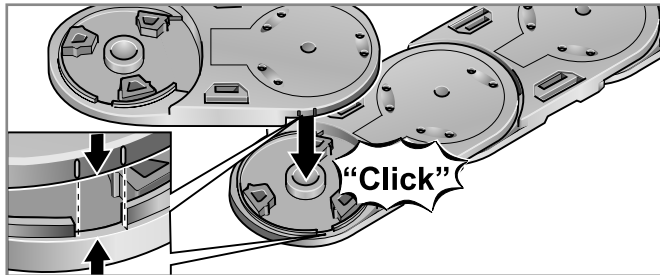

Step 1

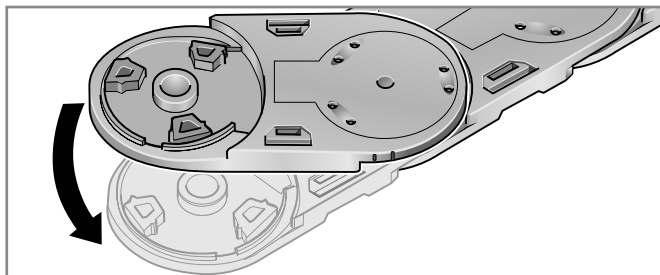

Step 2

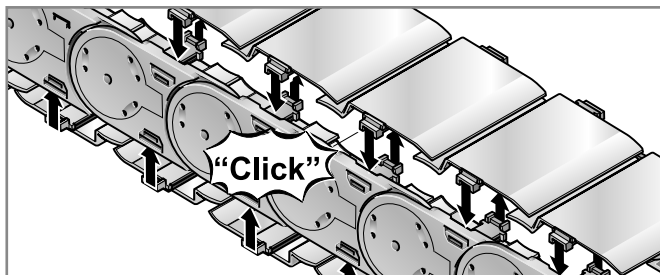

Step 3

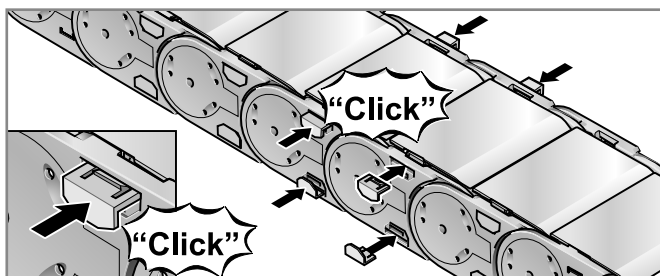

Step 4

Disassembly

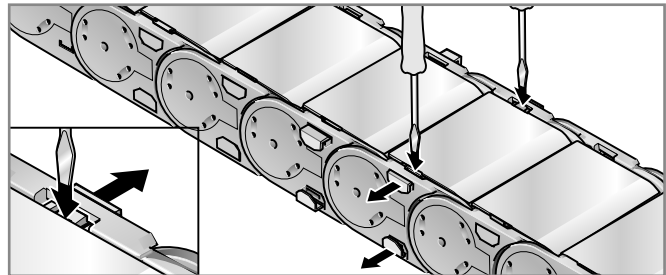

Step 1

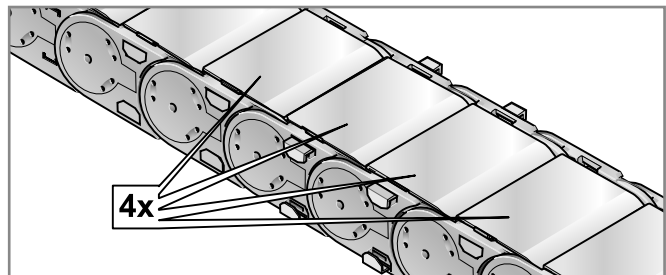

Step 2

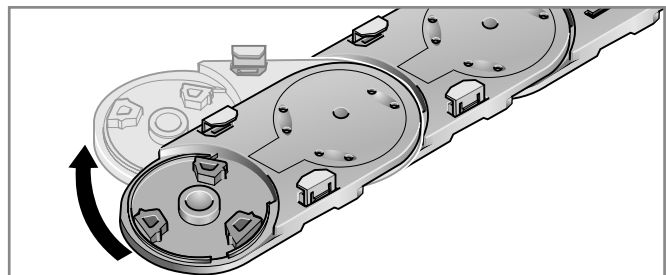

Step 3

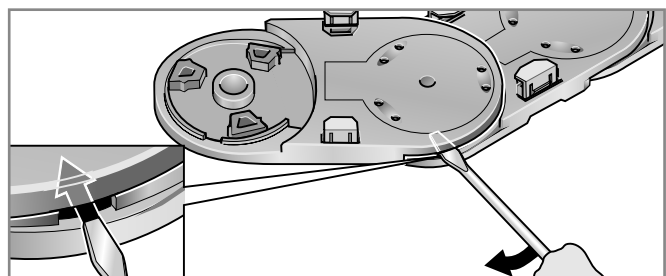

Step 4



Cable drag chain systems

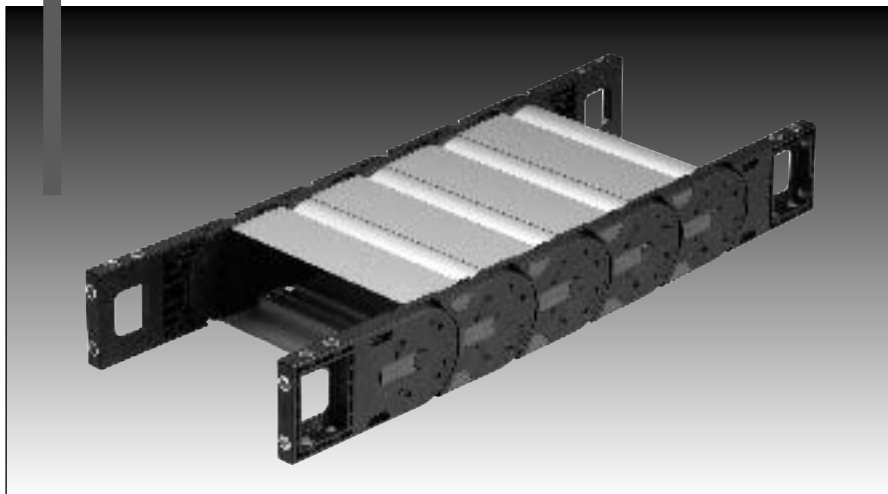

ClosedLine

MP 82.3 G



MP 82.3 G - ClosedLine

Order variants

Style (order code)						
Configuration (order code)						
Radius (order code) <small>The radii can be combined with any internal width</small>						
in inch						
Internal width (order code)						
in inch						
Outside width in inch						
MP82.3G 118	6.42	4.65	118			
MP82.3G 143	7.40	5.63	143			
MP82.3G 168	8.39	6.61	168			
MP82.3G 193	9.37	7.60	193			
MP82.3G 218	10.35	8.58	218			
MP82.3G 243	11.34	9.57	243			
MP82.3G 268	12.32	10.55	268			
MP82.3G 293	13.31	11.54	293	7.87	200	
MP82.3G 318	14.29	12.52	318	9.84	250	
MP82.3G 343	15.28	13.50	343	11.81	300	
MP82.3G 368	16.26	14.49	368	13.78	350	
MP82.3G 418	18.23	16.46	418	15.75	400	
MP82.3G xxx	inside + 1.26	>4.65 -23.62	Alu	19.69	500	
				25.59	650	
						4
						5
						0
						9

Order-Number:

Configuration:

- 4 AL crossbar every link; w/bias
- 5 AL crossbar every link; w/o bias

Style:

- 0 Standard (PA/black)
- 9 Custom version

Sample order:

0823 118 200 0400

Internal width = 4.65 in (118 mm)
 Radius = 7.87 in (200 mm)
 Configuration = 4
 Style = 0

Ideal operating conditions:

- Extremely high accelerations
- Extremely high speeds
- Very high additional loads
- Long travel distances
- Extreme self-supporting lengths

Features

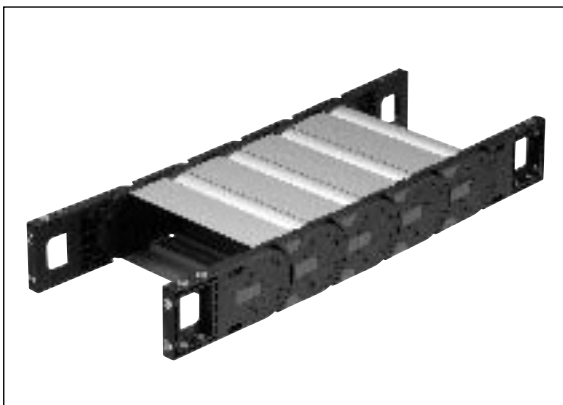

- Chain bracket, can be fastened on three sides
- Side links with CLICK lock for easy opening
- Crossbar strain relief can be integrated into chain bracket
- C-profile rail can be integrated into chain bracket
- Foldable shelf system for reliable cable guidance
- Crossbar/cover can be removed from inside and outside flexure curve
- Radii with medium bias (R) for all applications
- Aluminum frame bridges with integrated lock grid in variable lengths
- Integrable separator for cable separation
- ESD cable drag chains for use in areas of electrostatic discharge

Technical data

Chain link dimensions (inch) (mm)

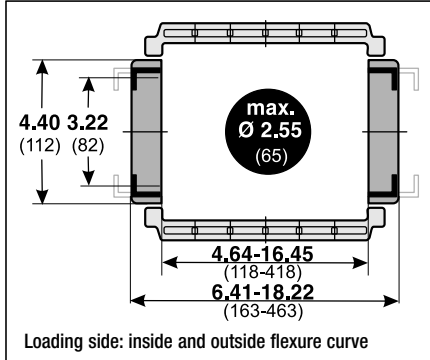

Material characteristics standard (PA/black)

Operating temperature: -22 to 248° F
 Gliding friction factor: 0.30
 Static friction factor: 0.45
 Fire classification: Based on UL94 HB

Other material properties on request

Technical specifications

Travel distance, gliding, L_g : 492.13 ft
 Travel distance, self-supporting, L_s : see diagram
 Travel distance, vertical, hanging, L_{vh} : 393.70 ft
 Travel distance, vertical, upright, L_{vu} : 19.69 ft
 Rotated 90°, self-supporting, L_{90r} : 9.84 ft
 Speed, gliding, V_g : 16.40 ft/s
 Speed, self-supporting, V_s : 65.62 ft/s
 Acceleration, gliding, a_g : 82.02 ft/s²
 Acceleration, self-supporting, a_s : 131.23 ft/s²

Self-supporting length

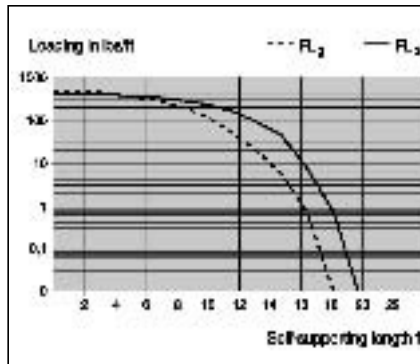
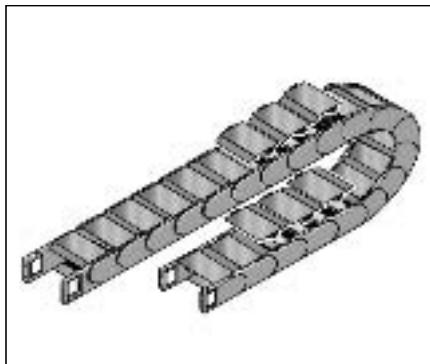

FL_g :
 Ideal installation situation for high stresses at the limit of the max. travel parameters. In this range the chain upper run is still biased, straight or has a max. sag of 32.81 – 164.04 ft (10 – 50 mm) depending on the type of chain.

FL_s :
 Satisfactory installation position for many applications working in the lower to middle range of the max. travel parameters. Depending on the chain type, the sag of the chain upper run is >32.81 – 164.04 ft (10 – 50 mm) but certainly less than the max. sag.

If the sag is greater than FL_s , the arrangement is unsuitable and should be avoided. Please choose a more stable Murrplastik cable drag chain.

Determining the chain length

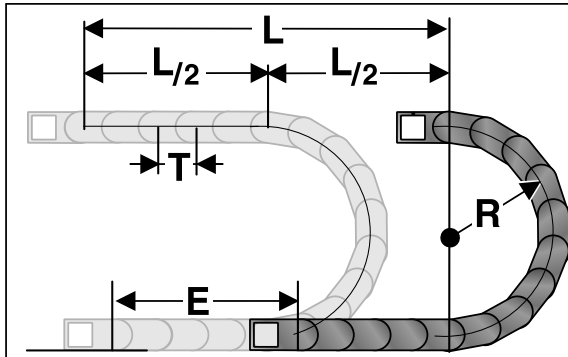

Determining the chain length

$$\text{Length} = \frac{L}{2} + \pi \times R + E$$

≈ 1 ft(m) chain = 3(9) links each 4.95 in (118 mm)

The fixed point of the cable drag chain should be connected in the middle of the travel distance. This arrangement gives the shortest connection between the fixed point and the moving point and thus the most efficient chain length.

Installation dimensions (in inch)

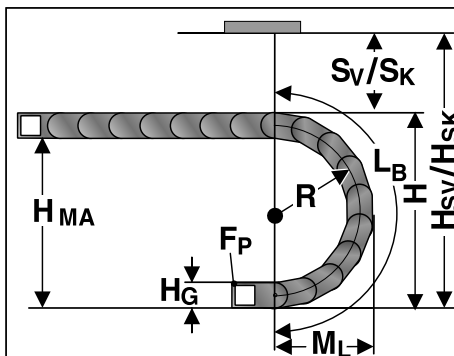

Radius R	7.87	9.84	11.81	13.78	15.75	19.69	25.59
Outside height of chain link (H_o)	4.41	4.41	4.41	4.41	4.41	4.41	4.41
Height of bend (H)	20.55	24.49	28.43	32.36	36.30	44.17	55.98
Height of moving end connection (H_{Ma})	16.14	20.08	24.02	27.95	31.89	39.76	51.57
Safety margin with bias (S_v)	1.97	1.97	1.97	1.97	1.97	1.97	1.97
Installation height with bias (H_{sv})	22.52	26.46	30.39	34.33	38.27	46.14	57.95
Safety margin without bias (S_k)	1.18	1.18	1.18	1.18	1.18	1.18	1.18
Installation height without bias (H_{sk})	21.73	25.67	29.61	33.54	37.48	45.35	57.17
Arc projection (M_l)	14.92	16.89	18.86	20.83	22.80	26.73	32.64
Bend length (L_b)	36.93	43.11	49.29	55.47	61.65	74.02	92.56



MP 82.3 G - ClosedLine

Chain bracket

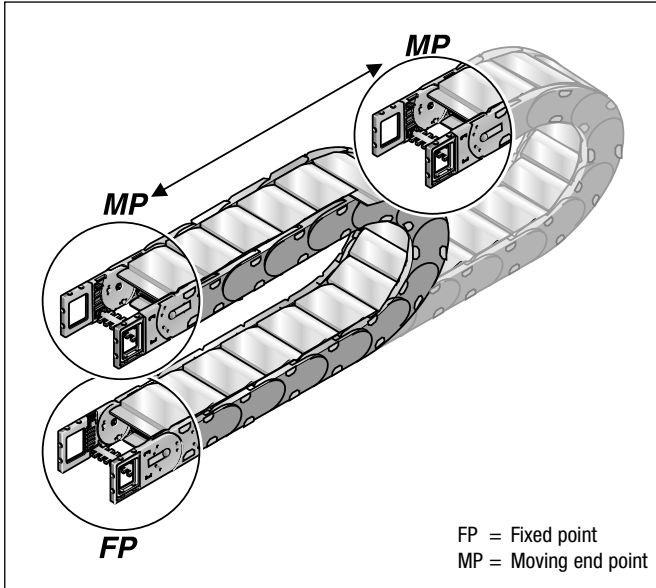

Flexible chain bracket

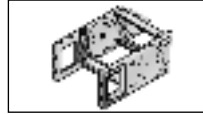

Flexible chain bracket

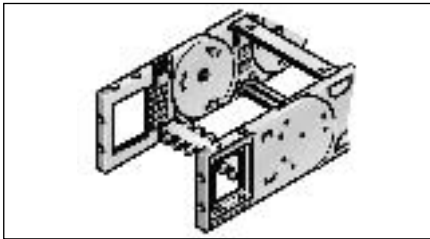

Type	Order no.	Version	Pack qty.
KA 82!1-FB	0820000056	with bush	1
KA 82!1-FB	0820000057	with bush	1
KA 82!1-FG	0820000058	with thread	1
KA 82!1-FG	0820000059	with thread	1

This chain bracket offers universal connection options (top, bottom and front) and is attached to the ends of the chain like a side link. This allows the chain to move right up to the bracket. Each chain requires one male and one female bracket. Use M10 screws for connecting. Extrusion-coated metal bushes with either a through-hole (-FB) or a threaded hole (-FG) ensure the permanent, high-strength transmission of even extreme forces onto the cable drag chain.

Flexible chain bracket

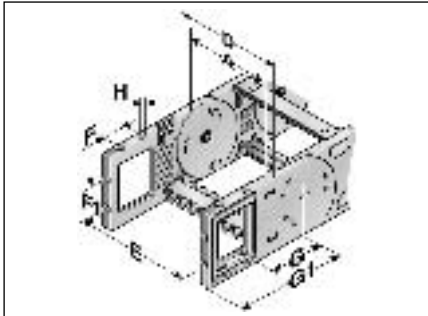

Flexible with through-hole

Type	A inch	D inch	E inch	F inch	F1 inch	G inch	G1 inch	H Ø inch
KA82-FB	4.65	6.42	5.55	1.38	2.6	4.61	7.17	0.43
KA82-FB	5.63	7.40	6.54	1.38	2.6	4.61	7.17	0.43
KA82-FB	6.61	8.39	7.52	1.38	2.6	4.61	7.17	0.43
KA82-FB	7.60	9.37	8.50	1.38	2.6	4.61	7.17	0.43
KA82-FB	8.58	10.35	9.49	1.38	2.6	4.61	7.17	0.43
KA82-FB	9.57	11.34	10.47	1.38	2.6	4.61	7.17	0.43
KA82-FB	10.55	12.32	11.46	1.38	2.6	4.61	7.17	0.43
KA82-FB	11.54	13.31	12.44	1.38	2.6	4.61	7.17	0.43
KA82-FB	12.52	14.92	13.43	1.38	2.6	4.61	7.17	0.43
KA82-FB	13.50	15.28	14.41	1.38	2.6	4.61	7.17	0.43
KA82-FB	14.49	16.26	15.39	1.38	2.6	4.61	7.17	0.43
KA82-FB	16.46	18.23	17.36	1.38	2.6	4.61	7.17	0.43
KA82-FB	variable	A+1.77	A+0.91	1.38	2.6	4.61	7.17	0.43

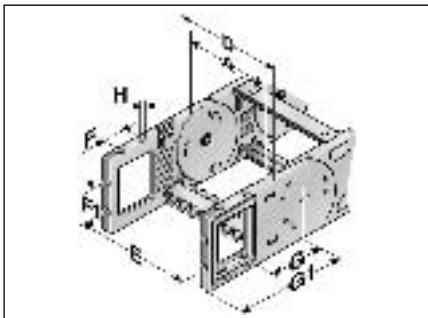

Flexible with threaded bush

Type	A inch	D inch	E inch	F inch	F1 inch	G inch	G1 inch	H Ø
KA82-FG	4.65	6.42	5.55	1.38	2.6	4.61	7.17	M10
KA82-FG	5.63	7.40	6.54	1.38	2.6	4.61	7.17	M10
KA82-FG	6.61	8.39	7.52	1.38	2.6	4.61	7.17	M10
KA82-FG	7.60	9.37	8.50	1.38	2.6	4.61	7.17	M10
KA82-FG	8.58	10.35	9.49	1.38	2.6	4.61	7.17	M10
KA82-FG	9.57	11.34	10.47	1.38	2.6	4.61	7.17	M10
KA82-FG	10.55	12.32	11.46	1.38	2.6	4.61	7.17	M10
KA82-FG	11.54	13.31	12.44	1.38	2.6	4.61	7.17	M10
KA82-FG	12.52	14.92	13.43	1.38	2.6	4.61	7.17	M10
KA82-FG	13.50	15.28	14.41	1.38	2.6	4.61	7.17	M10
KA82-FG	14.49	16.26	15.39	1.38	2.6	4.61	7.17	M10
KA82-FG	16.46	18.23	17.36	1.38	2.6	4.61	7.17	M10
KA82-FG	variable	A+1.77	A+0.91	1.38	2.6	4.61	7.17	M10



MP 82.3 G - Accessories

Separator

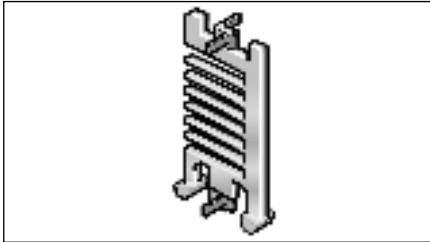

Separator

Type	Order no.	Designation	Lock grid spacing inch	Pack qty.
TR 82	082000009200	Separator	0.20	1

We recommend that separators be used if multiple round cables or conduits with differing diameters are to be installed. An offset configuration of the separators is advisable.

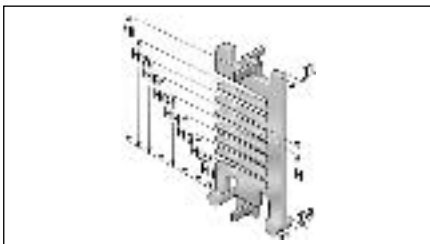

Separator

Type	TI inch	H inch	H1 inch	H2 inch	H3 inch	H4 inch	H5 inch	H6 inch	H7 inch	HI inch
TR 82	0.14	0.21	0.48	0.81	1.13	1.46	1.79	2.11	2.44	3.13

Shelving system

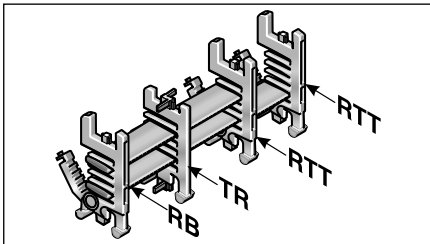

Shelving system

Type	Order no.	Designation	Width inch	Lock grid spacing inch	Pack qty.
RB 056-7	100000005600	RB 056-7 Shelf	2.20	0.20	1
RB 066-7	100000006600	RB 066-7 Shelf	2.60	0.20	1
RB 081-7	100000008100	RB 081-7 Shelf	3.19	0.20	1
RB 106-7	100000010600	RB 106-7 Shelf	4.17	0.20	1
RB 116-7	100000011600	RB 116-7 Shelf	4.57	0.20	1
RB 166-7	100000016600	RB 166-7 Shelf	6.54	0.20	1
RB 216-7	100000021600	RB 216-7 Shelf	8.50	0.20	1
RTT 82	100090822000	RTT 82 Shelf support, divisible		0.20	1

In connection with at least two shelf supports (RTT) the shelf becomes a shelving system. The additional levels prevent cables from criss-crossing and therefore destroying each other, while also avoiding excessive friction. The shelving system may be pre-assembled on request.

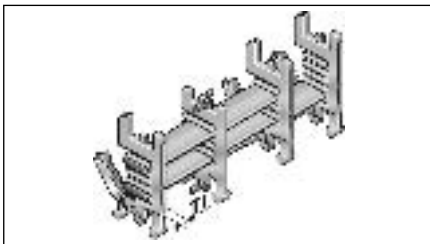

Shelving system

Type	TI inch
RTT 82	0.31

Chain bracket cover D8

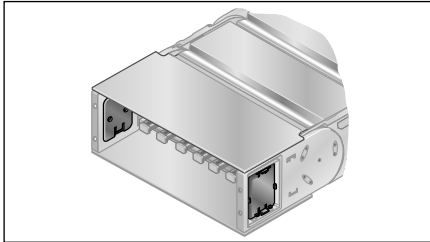

Side link cover

Type	Order no.	Pack qty.
Cover D8 KA 82.1-FB/FG	0823888002	2

Self-locking covers close the side mounting window on the flexible chain bracket (KA-FB/FG).

Chain bracket cover

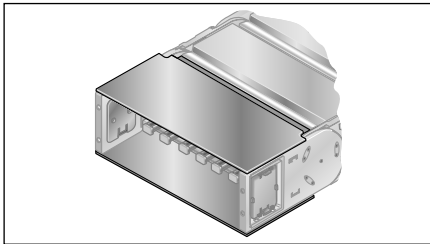

Covers for the flexible chain bracket (KA-FB/FG) allow for a closed variant up to the chain's end.

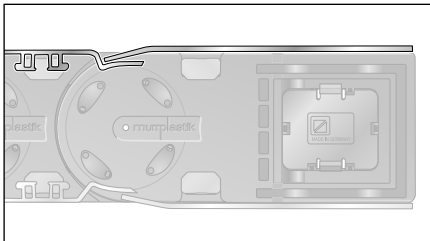

outside flexure curve

Type	Order no.	Inside width inch	Material	Pack qty.
Cover KA 82 FB/FG AB 118 1-2	0821118059	4.65	Anodized aluminum	1
Cover KA 82 FB/FG AB 143 1-2	0821143059	5.63	Anodized aluminum	1
Cover KA 82 FB/FG AB 168 1-2	0821168059	6.61	Anodized aluminum	1
Cover KA 82 FB/FG AB 193 1-2	0821193059	7.60	Anodized aluminum	1
Cover KA 82 FB/FG AB 218 1-2	0821218059	8.58	Anodized aluminum	1
Cover KA 82 FB/FG AB 243 1-2	0821243059	9.57	Anodized aluminum	1
Cover KA 82 FB/FG AB 268 1-2	0821268059	10.55	Anodized aluminum	1
Cover KA 82 FB/FG AB 293 1-2	0821293059	11.54	Anodized aluminum	1
Cover KA 82 FB/FG AB 318 1-2	0821318059	12.52	Anodized aluminum	1
Cover KA 82 FB/FG AB 343 1-2	0821343059	13.50	Anodized aluminum	1
Cover KA 82 FB/FG AB 368 1-2	0821368059	14.49	Anodized aluminum	1
Cover KA 82 FB/FG AB 418 1-2	0821418059	16.46	Anodized aluminum	1

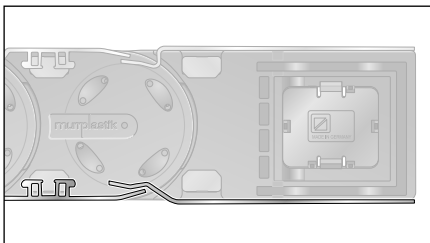

outside flexure curve

Type	Order no.	Inside width inch	Material	Pack qty.
Cover KA 82 FB/FG AB 118 2-2	0821118060	4.65	Anodized aluminum	1
Cover KA 82 FB/FG AB 143 2-2	0821143060	5.63	Anodized aluminum	1
Cover KA 82 FB/FG AB 168 2-2	0821168060	6.61	Anodized aluminum	1
Cover KA 82 FB/FG AB 193 2-2	0821193060	7.60	Anodized aluminum	1
Cover KA 82 FB/FG AB 218 2-2	0821218060	8.58	Anodized aluminum	1
Cover KA 82 FB/FG AB 243 2-2	0821243060	9.57	Anodized aluminum	1
Cover KA 82 FB/FG AB 268 2-2	0821268060	10.55	Anodized aluminum	1
Cover KA 82 FB/FG AB 293 2-2	0821293060	11.54	Anodized aluminum	1
Cover KA 82 FB/FG AB 318 2-2	0821318060	12.52	Anodized aluminum	1
Cover KA 82 FB/FG AB 343 2-2	0821343060	13.50	Anodized aluminum	1
Cover KA 82 FB/FG AB 368 2-2	0821368060	14.49	Anodized aluminum	1
Cover KA 82 FB/FG AB 418 2-2	0821418060	16.46	Anodized aluminum	1



MP 82.3 G - Accessories

Chain bracket cover

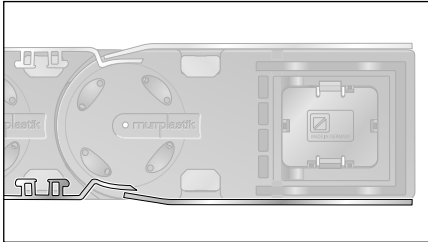

inside flexure curve

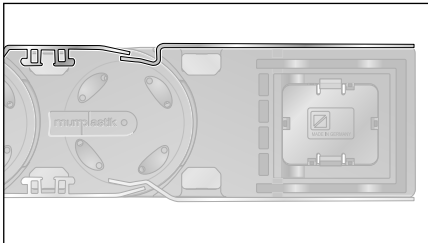

inside flexure curve

Type	Order no.	Inside width inch	Material	Pack qty.
Cover KA 82 FB/FG IB 118 1-2	0821118057	4.65	Anodized aluminum	1
Cover KA 82 FB/FG IB 143 1-2	0821143057	5.63	Anodized aluminum	1
Cover KA 82 FB/FG IB 168 1-2	0821168057	6.61	Anodized aluminum	1
Cover KA 82 FB/FG IB 193 1-2	0821193057	7.60	Anodized aluminum	1
Cover KA 82 FB/FG IB 218 1-2	0821218057	8.58	Anodized aluminum	1
Cover KA 82 FB/FG IB 243 1-2	0821243057	9.57	Anodized aluminum	1
Cover KA 82 FB/FG IB 268 1-2	0821268057	10.55	Anodized aluminum	1
Cover KA 82 FB/FG IB 293 1-2	0821293057	11.54	Anodized aluminum	1
Cover KA 82 FB/FG IB 318 1-2	0821318057	12.52	Anodized aluminum	1
Cover KA 82 FB/FG IB 343 1-2	0821343057	13.50	Anodized aluminum	1
Cover KA 82 FB/FG IB 368 1-2	0821368057	14.49	Anodized aluminum	1
Cover KA 82 FB/FG IB 418 1-2	0821418057	16.46	Anodized aluminum	1

Type	Order no.	Inside width inch	Material	Pack qty.
Cover KA 82 FB/FG IB 118 2-2	0821118058	4.65	Anodized aluminum	1
Cover KA 82 FB/FG IB 143 2-2	0821143058	5.63	Anodized aluminum	1
Cover KA 82 FB/FG IB 168 2-2	0821168058	6.61	Anodized aluminum	1
Cover KA 82 FB/FG IB 193 2-2	0821193058	7.60	Anodized aluminum	1
Cover KA 82 FB/FG IB 218 2-2	0821218058	8.58	Anodized aluminum	1
Cover KA 82 FB/FG IB 243 2-2	0821243058	9.57	Anodized aluminum	1
Cover KA 82 FB/FG IB 268 2-2	0821268058	10.55	Anodized aluminum	1
Cover KA 82 FB/FG IB 293 2-2	0821293058	11.54	Anodized aluminum	1
Cover KA 82 FB/FG IB 318 2-2	0821318058	12.52	Anodized aluminum	1
Cover KA 82 FB/FG IB 343 2-2	0821343058	13.50	Anodized aluminum	1
Cover KA 82 FB/FG IB 368 2-2	0821368058	14.49	Anodized aluminum	1
Cover KA 82 FB/FG IB 418 2-2	0821418058	16.46	Anodized aluminum	1

Crossbar strain relief plate RS-ZL



Crossbar strain relief plate RS-ZL

Type	Order no.	For internal width inch	Pack qty.
RS-ZL 118-7	072011800010	4.65	1
RS-ZL 143-7	072014300010	5.63	1
RS-ZL 168-7	072016800010	6.61	1
RS-ZL 193-7	072019300010	7.60	1
RS-ZL 218-7	072021800010	8.58	1
RS-ZL 243-7	072024300010	9.57	1

Fixed integrated frame bridge strain relief plates in the chain brackets. Accommodated to all widths of the frame ridges, up to 9.57 in (243 mm) in size. May be assembled on the inside and outside flexure curves at both chain endings.

Strain relief type BAK

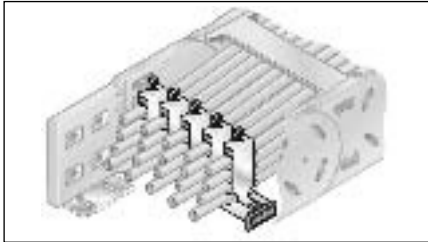

Strain relief with hooped clamp

Type	Order no.	Designation	Ø inch	Number of seats	Pack qty.
C-rail	81661610	C-profile rail			1
BA 12	81661036	BA 12 Hooped clamp	0.35–0.47	1	1
BAK 14	81661002	BAK 14 Hooped clamp	0.24–0.55	1	1
BAK 18	81661004	BAK 18 Hooped clamp	0.55–0.71	1	1
BAK 22	81661006	BAK 22 Hooped clamp	0.71–0.87	1	1
BAK 26	81661008	BAK 26 Hooped clamp	0.87–1.02	1	1
BAK 30	81661010	BAK 30 Hooped clamp	1.02–1.18	1	1
BAK 34	81661000	BAK 34 Hooped clamp	1.18–1.34	1	1
BAK 38	81661044	BAK 38 Hooped clamp	1.34–1.50	1	1
BAK 42	81661032	BAK 42 Hooped clamp	1.50–1.65	1	1
BAK 46	81661050	BAK 46 Hooped clamp	1.65–1.81	1	1
BA 12/2	81661038	BA 12/2 Hooped clamp	0.35–0.47	2	1
BAK 14/2	81661012	BAK 14/2 Hooped clamp	0.39–0.55	2	1
BAK 18/2	81661014	BAK 18/2 Hooped clamp	0.55–0.71	2	1
BAK 22/2	81661016	BAK 22/2 Hooped clamp	0.71–0.87	2	1
BAK 26/2	81661018	BAK 26/2 Hooped clamp	0.87–1.02	2	1
BAK 30/2	81661048	BAK 30/2 Hooped clamp	1.02–1.18	2	1
BAK 34/2	81661044	BAK 34/2 Hooped clamp	1.18–1.34	2	1
BAK 38/2	81661046	BAK 38/2 Hooped clamp	1.34–1.50	2	1
BAK 42/2	81661034	BAK 42/2 Hooped clamp	1.50–1.65	2	1
BAK 12/3	81661020	BAK 12/3 Hooped clamp	0.35–0.47	3	1
BAK 14/3	81661022	BAK 14/3 Hooped clamp	0.47–0.55	3	1
BAK 16/3	81661024	BAK 16/3 Hooped clamp	0.55–0.63	3	1
BAK 18/3	81661026	BAK 18/3 Hooped clamp	0.63–0.71	3	1
BAK 20/3	81661028	BAK 20/3 Hooped clamp	0.71–0.79	3	1
BAK 22/3	81661030	BAK 22/3 Hooped clamp	0.79–0.87	3	1

Fixed integrated strain relief in the chain connections. Available in all widths (also individual widths for aluminum frame ridges). May be assembled on the inside and outside flexure curves at both chain endings. Chain content is secured through hooped clamps that are available in different sizes. Material: Galvanized steel.

When ordering please indicate the type of chain and internal width.



MP 82.3 G - Accessories

Assembly Disassembly

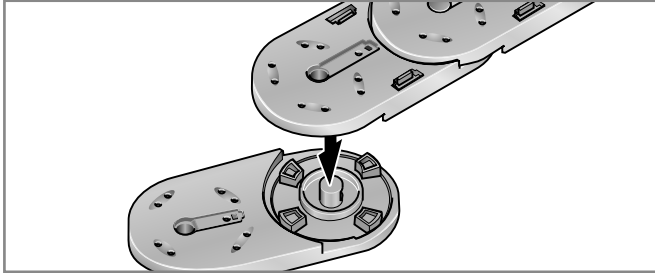

Step 1

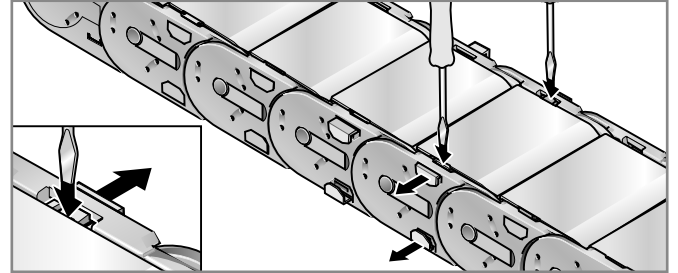

Step 1

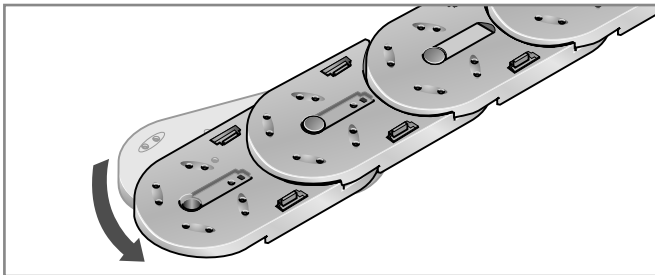

Step 2

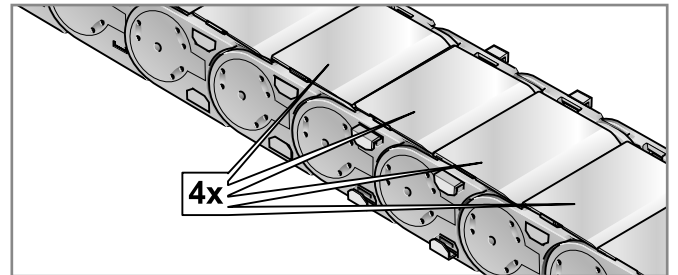

Step 2

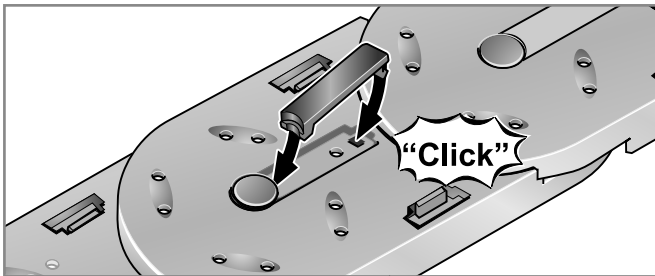

Step 3

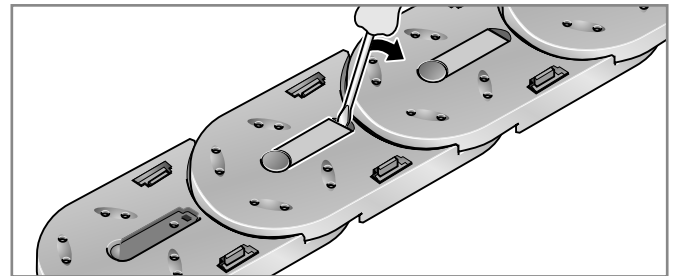

Step 3

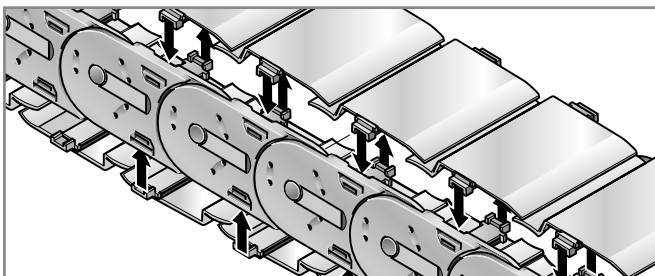

Step 4

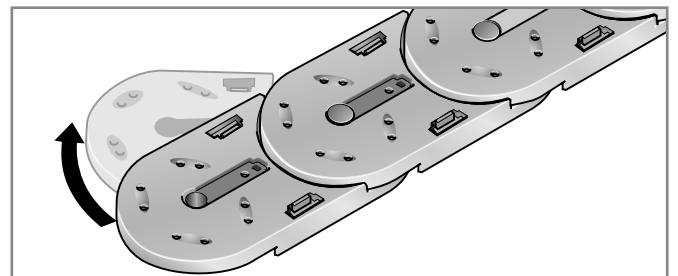

Step 4

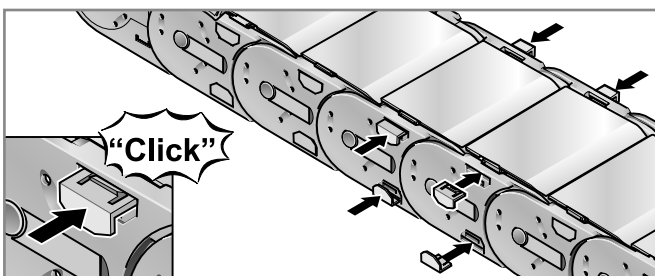

Step 5

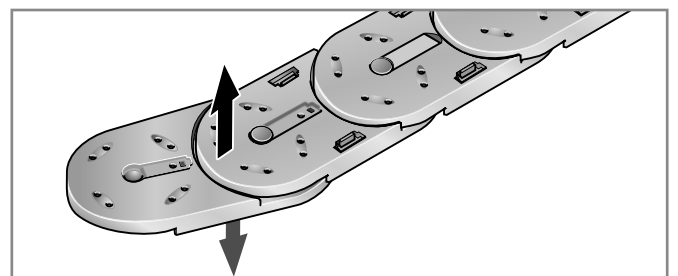

Step 5

VARIABLE GUIDE CHANNEL SYSTEMS

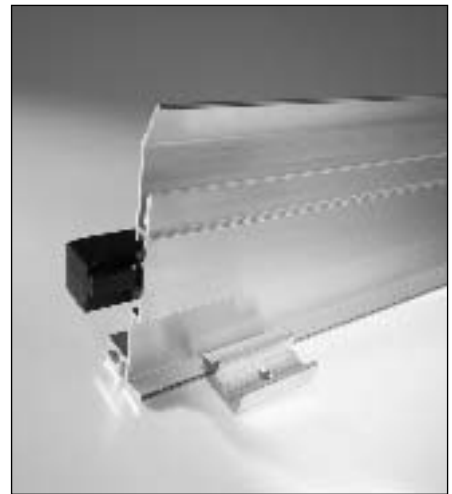

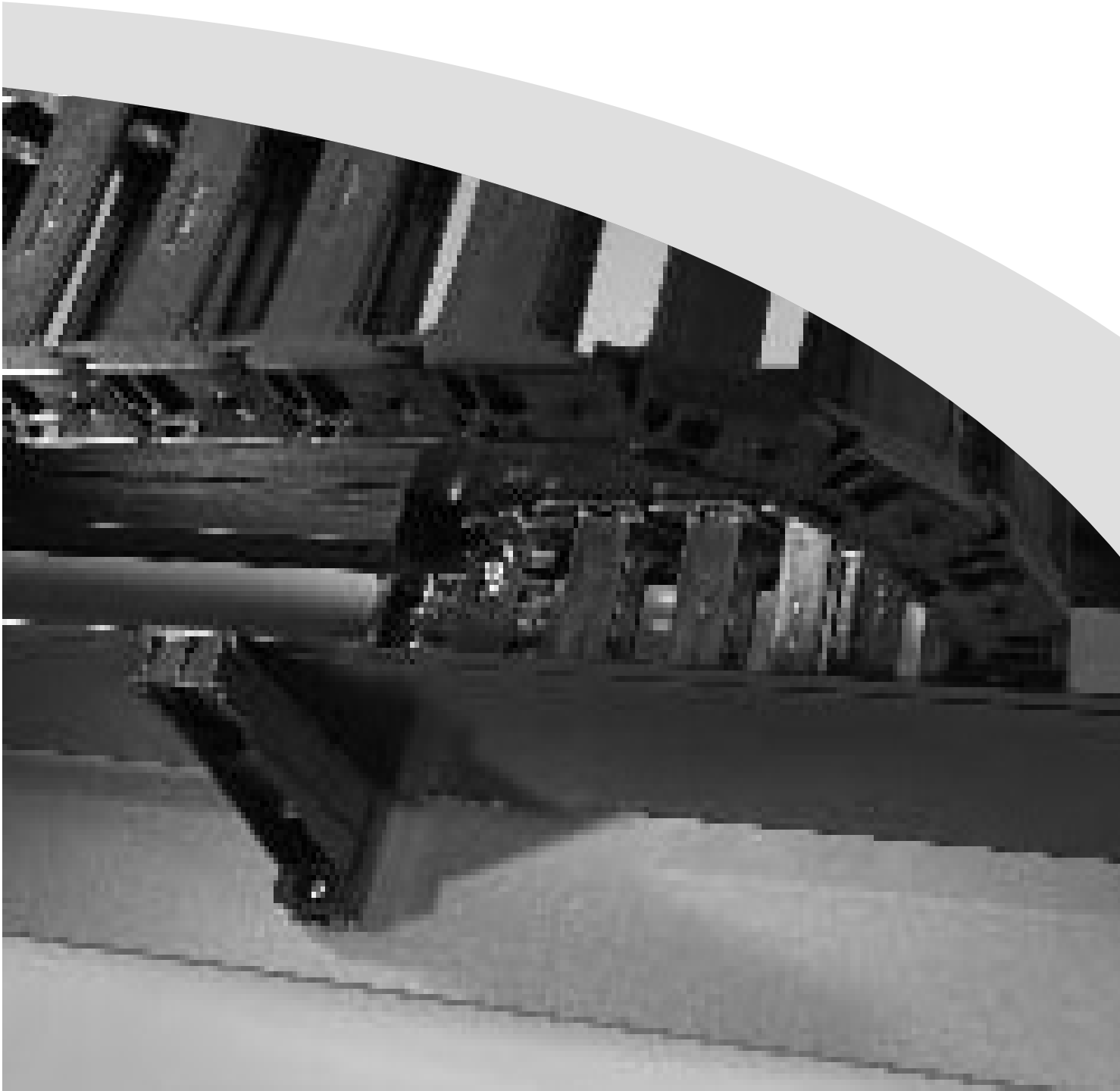

Guide channel systems for cable drag chains serve as trays for short travel distances and at the same time as guides for long travel distances. If no guide channel is used it is possible that the chain links may lay and move incorrectly. Especially for large bend radii as the side guidance does not exist. In most applications the cables/conduits enter the chain at a position central to the travel. This gives the shortest

length of chain. In this case the chain is about half as long as the travel distance. If the chain is moved to the left (see illustration below) it simply rolls in the channel. If it is moved to the right, then it stacks on top of itself once the unsupported length has been exceeded. If the movement is continued to the right, then the glide rail adjusts the difference in height and guarantees the minimum possible friction. This ensures the optimum free and correct running of the cable drag chain.

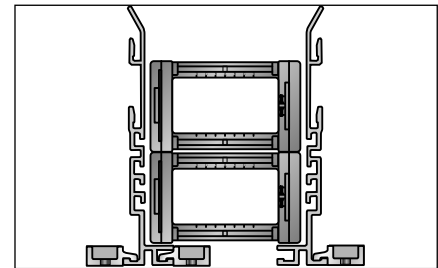

Section A-A:
The cable drag chain glides on itself

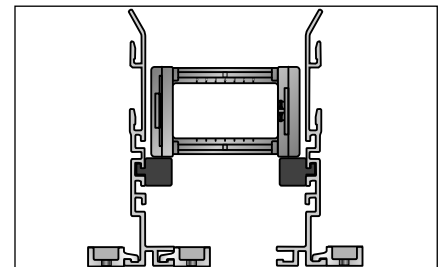

Section B-B:
The cable drag chain runs on the glide rail

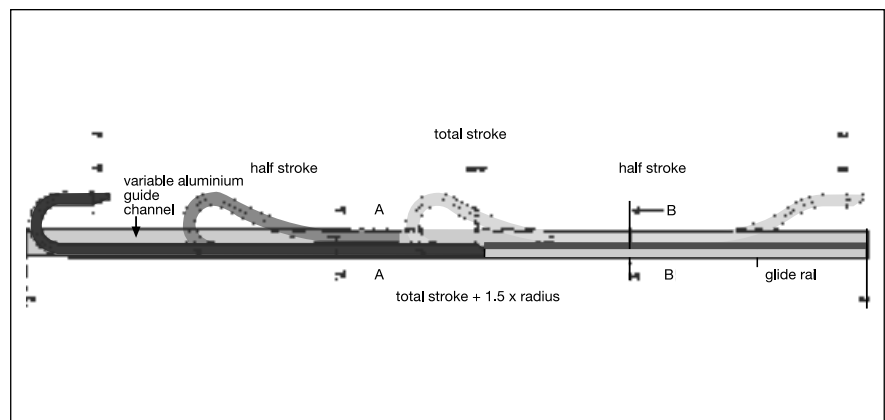



System advantages of VAW

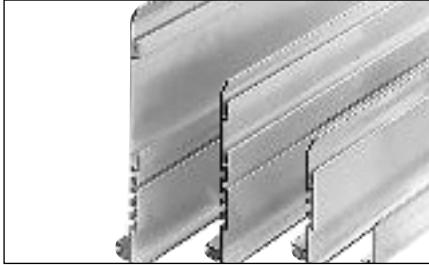

Compatible profile

The variable aluminum guide channel systems consist of different aluminum sections. Each is formed to ideally suit the Murrplastik cable drag chain.

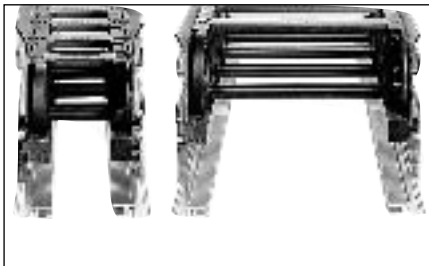

Variable in the chain widths and heights

The guide channel sections fit different chain types and widths. They can be modified quickly on site.



Space saving of the guide channel systems

Small footprint required for the variable guide channel systems- Space is saved when using the variable guide channel systems. When mounted, the complete system is barely wider than the chain itself.

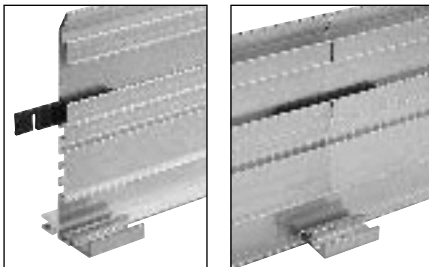

Accurate and snag-free alignment

No screwing or welding is required for the individual sections in the variable guide channel system. The channel sections are perfectly aligned thanks to special plastic connectors which are placed in a groove specially provided for that purpose.

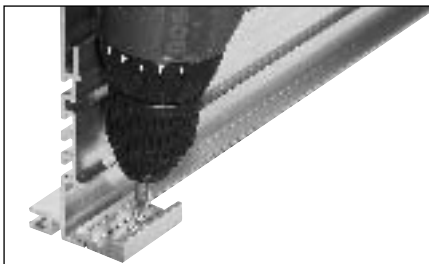

Fast installation

The variable guide channel systems are fixed in place with special clamping pieces. The mounting holes of these pieces are used as drill templates. The clamping pieces double up as stacking for the chain brackets. They must be placed on the inside of the guide channel. It is also advisable to fit additional clamping pieces on the outside of the guide channel.

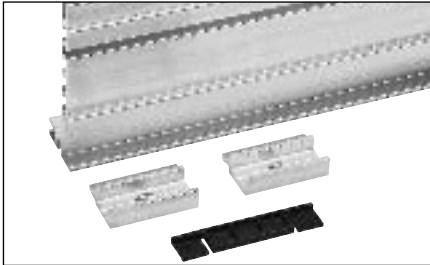

Installation set included

The correct quantity of parts required for joining and mounting is delivered with all variable guide channel systems. These fastening parts are included in the overall channel system price.

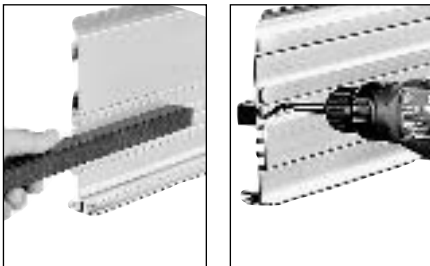

Simple handling

The glide rail is simply slid into the guide channel section. Securing them into position only requires a screw in the first and last rail. A variable guide channel system is recommended when the self-supporting length is exceeded.



Center piece VAW-MT

The use of the guide channel middle section is appropriate for cable drag chains of similar and varying sizes. The cable drag chains can be run parallel and also independently of each other within their guide channels.

The cable drag chains are securely separated from each other.



Low noise level

A level surface for the chain to run on is created by the T-slot in the glide rail. This ensures that the cable drag chain systems run smoothly. The noise level is decreased.

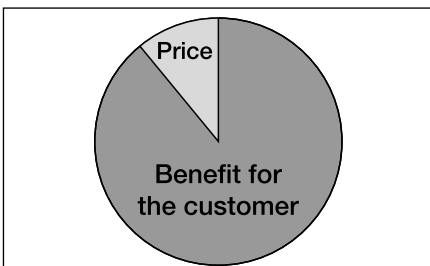

Cost-effective

The use of standard components saves cost in this case. It is up to 70 % cheaper than conventional systems.

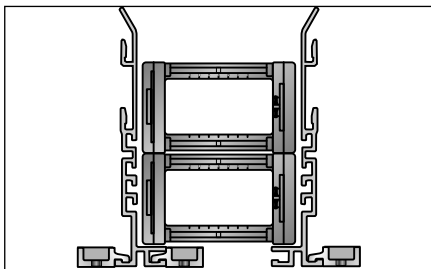
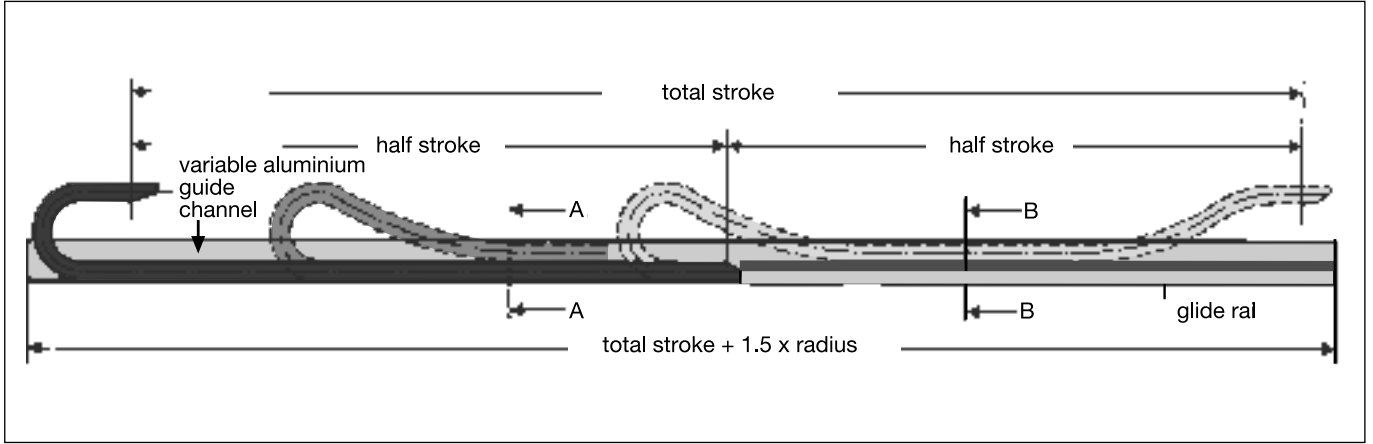

Section A-A:
The cable drag chain glides on itself

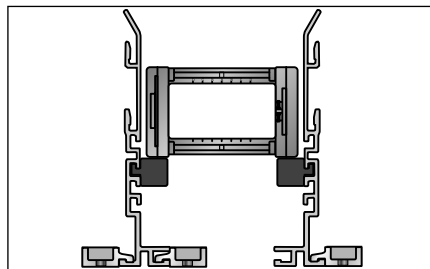

Section B-B:
The cable drag chain runs on the glide rail

Lowered fixing point

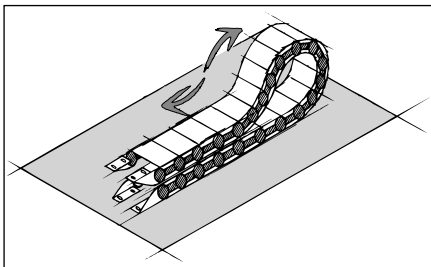

It is sometimes necessary to lower the height of the moving attachment point.

In such cases, modifications to the chain layout should be noted (e.g. extension of chain).

Please consult with our engineers.

Selection criteria

Information on the following parameters is required for the layout of a variable guide channel system:

- Cable drag chain type (width, radius, installation)
- Travel distance
- Chain contents or weight per meter
- Speed of travel
- Acceleration/retardation of chain
- Cross acceleration yes/no
- Environment

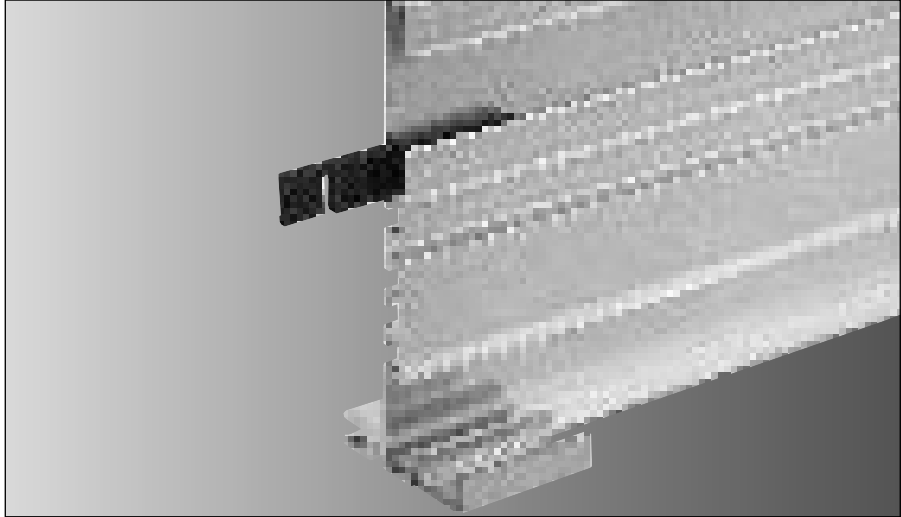

Selection criteria

It is advisable to use a guide channel system for the entire travel distance.

If the cable entry is at the center of the traverse, then a glide rail is required of a length equal to half of the travel distance.

Example:

Travel distance: 787.40 in (20.000 mm)

Entry point: Center

Chain type: MP 35086 R 100 without bias
with 176 links = 401.89 in (10.208 mm)

65.62 ft (20 m) guide channel VAW 80106

32.81 ft (10 m) glide rail GSP 20/20

Selection criteria

To properly install the guide channel, a level surface is required. The channel pieces (standard length 6.56 ft (2m)) are arranged to one another. They are connected edge to edge by plastic wedges in order to eliminate any unevenness. This eliminates any offset and impact. The method of assembly also prevents any inherent deformation of the channel.

The distance between the 2 side walls of the guide channel must be determined by chain outside width + 0.12 to 0.39 in (+ 3 to 10 mm), based on chain type (see channel clearance table, page 344)

Clamping pieces are used to secure the guide channel sections to the base construction (e.g. base or support arms).

These clip over the inside or outside foot on the bottom of the wall at any position along the length. The hole in the mounting plate can act as a drilling guide when using a hand drill. They are easily accessible with a hand drill. If the self-supporting length of the cable drag chain is exceeded, for the part of the guide channel where the upper run cannot glide on the lower, a glide rail must be used (see cross section B-B).

The GSP glide rail does not require screws, apart from in the first and last rail. The glide rail is simply pushed into the slot corresponding to the height of the chain in use. The guide along the full length of the channel (T-slot) provides an even surface. This enables the chain system to run smoothly, even at high travel speeds.



Selecting self-supporting variable guide channels

Which guide channel should I use and when?

Variable in the chain widths and heights

The basic idea of the VAW variable guide channel system has been to develop a profile that fits various types and widths of cable drag

chains. In addition, the installation should be as simple as possible.

The system consists of profiles. Each profile contains various grooves into which you may enter a gliding rail. The type of cable drag

chain determines into which groove you must enter the gliding rail.

The table below provides simple information on which guide channel system is suitable for which type of cable drag chain.

Type	Inside width	Radius	Guide channel	Order no.	Distance plate	Order no.
MP 10.1	---	---	---	---	---	---
MP 14	0.63	as desired	VAW 25	111410190700	DBP 14016	111212120000
	0.79	as desired	VAW 25	111410190700	DBP 14016/18018	111212240000
	1.18	as desired	VAW 25	111410190700	DBP 14030/18025	111212260000
	1.57	as desired	VAW 25	111410190700	DBP 14040/18037	111212280000
MP 15	0.63	as desired	VAW 25	111410190700	DBP 14016	111212120000
	0.79	as desired	VAW 25	111410190700	DBP 14016/18018	111212240000
	1.18	as desired	VAW 25	111410190700	DBP 14030/18025	111212260000
	1.57	as desired	VAW 25	111410190700	DBP 14040/18037	111212280000
MP 18.1/ MP 18.2x	0.59	as desired	VAW 25	111410190700	DBP 14016/18018	111212240000
	0.71	as desired	VAW 25	111410190700	DBP 14016/18018	111212240000
	0.98	as desired	VAW 25	111410190700	DBP 14030/18025	111212260000
	1.46	as desired	VAW 25	111410190700	DBP 14040/18037	111212280000
	1.97	as desired	VAW 25	111410190700	DBP 14050/18050	111212300000
	2.76	as desired	VAW 25	111410190700	DBP 18070	111212320000
MP 3001	1.02	as desired	VAW 35	111420100700	DBP 3001	111212100000
MP 3002	1.46	as desired	VAW 35	111420100700	DBP 3002	111212120000
MP 3002.5	2.20	as desired	VAW 35	111420100700	DBP 3002.5	111212300000
MP 3003	2.44	as desired	VAW 35	111420100700	DBP 3003/35062	111212140000
MP 3003.5	2.99	as desired	VAW 35	111420100700	DBP 3003.5	111212150000
MP 3004	3.43	as desired	VAW 35	111420100700	DBP 3004/35086	111212160000

Type	Inside width	Radius	Guide channel	Order no.	Distance plate	Order no.
MP 3005	3.98	as desired	VAW 35	111420100700	DBP 3005/35102	111212180000
MP 3006	4.92	as desired	VAW 35	111420100700	2 x DBP 3001 for internal clamping	111212100000
MP 25026 G	1.02	as desired	VAW 35	111420100700	DBP 3001	111212100000
MP 25037 G	1.46	as desired	VAW 35	111420100700	DBP 3002	111212120000
MP 25062 G	2.44	as desired	VAW 35	111420100700	DBP 3003/35062	111212140000
MP 25087 G	3.43	as desired	VAW 35	111420100700	DBP 3004/35086	111212160000
MP 25101 G	3.98	as desired	VAW 35	111420100700	DBP 3005/35102	111212180000
MP 25125 G	4.92	as desired	VAW 35	111420100700	2 x DBP 3001 for internal clamping	111212100000
MP 32	as desired	as desired	VAW 80	111430100700	2 x DBP 3001 for internal clamping	111212100000
					KL 50 for external clamping	111210300000
MP 32.2	as desired	as desired	VAW 80	111430100700	2 x DBP 3001 for internal clamping	111212100000
					KL 50 for external clamping	111210300000
MP 32.3	as desired	as desired	VAW 80	111430100700	2 x DBP 3001 for internal clamping	111212100000
					KL 50 for external clamping	111210300000
MP 35	2.44	as desired	VAW 35	111420100700	DBP 3003/35062	111212400000
	3.39	as desired	VAW 35	111420100700	DBP 3004/35086	111212600000
	4.02	as desired	VAW 35	111420100700	DBP 3005/35102	111212800000
	4.92	as desired	VAW 35	111420100700	2 x DBP 3001 for internal clamping	111212100000
	5.91	as desired	VAW 35	111420100700	2 x DBP 3001 for internal clamping	111212100000
MP 36062 G	2.44	as desired	VAW 35	111420100700	DBP 3003/35062	111212140000
MP 36086 G	3.39	as desired	VAW 35	111420100700	DBP 3004/35086	111212160000
MP 36102 G	4.02	as desired	VAW 35	111420100700	DBP 3005/35102	111212180000
MP 36125 G	4.92	as desired	VAW 35	111420100700	2 x DBP 3001 for internal clamping	111212100000
MP 44	as desired	as desired	VAW 80	111430100700	2 x DBP 3001 for internal clamping	111212100000
					KL 50 for external clamping	111210300000



Selecting self-supporting variable guide channels

Type	Inside width	Radius	Guide channel	Order no.	Distance plate	Order no.
MP 43 G	as desired	as desired	VAW 80	111430100700	2 x DBP 3001 for internal clamping	111212100000
					KL 50 for external clamping	111210300000
MP 41	as desired	as desired	VAW 80	111430100700	2 x DBP 3001 for internal clamping	111212100000
					KL 50 for external clamping	111210300000
MP 41.2	as desired	as desired	VAW 80	111430100700	2 x DBP 3001 for internal clamping	111212100000
					KL 50 for external clamping	111210300000
MP 41.3 G	as desired	as desired	VAW 80	111430100700	2 x DBP 3001 for internal clamping	111212100000
					KL 50 for external clamping	111210300000
MP 52.1	as desired	as desired	VAW 80	111430100700	2 x DBP 3001 for internal clamping	111212100000
					KL 50 for external clamping	111210300000
MP 52.2	as desired	as desired	VAW 80	111430100700	2 x DBP 3001 for internal clamping	111212100000
					KL 50 for external clamping	111210300000
MP 52.3	as desired	as desired	VAW 80	111430100700	2 x DBP 3001 for internal clamping	111212100000
					KL 50 for external clamping	111210300000
MP 66	as desired	as desired	VAW 80	111430100700	2 x DBP 3001 for internal clamping	111212100000
					KL 50 for external clamping	111210300000
MP 65 G	as desired	as desired	VAW 80	111430100700	2 x DBP 3001 for internal clamping	111212100000
					KL 50 for external clamping	111210300000
MP 62.1	as desired	as desired	VAW 80	111430100700	2 x DBP 3001 for internal clamping	111212100000
					KL 50 for external clamping	111210300000
MP 62.2	as desired	as desired	VAW 80	111430100700	2 x DBP 3001 for internal clamping	111212100000
					KL 50 for external clamping	111210300000
MP 62.3	as desired	as desired	VAW 80	111430100700	2 x DBP 3001 for internal clamping	111212100000
					KL 50 for external clamping	111210300000
MP 72	as desired	as desired	VAW 80	111430100700	2 x DBP 3001 for internal clamping	111212100000
					KL 50 for external clamping	111210300000



Selecting gliding variable guide channels

Type	Inside width	Radius	Guide channel	Order no.	Fastening	Order no.	Glide rail	Order no.
MP 10.1	---	---	---	---	---	---	---	---
MP 14	0.63	---	---	---	---	---	---	---
	0.79	---	---	---	---	---	---	---
	1.18	---	---	---	---	---	---	---
	1.57	---	---	---	---	---	---	---
MP 15	0.63	---	---	---	---	---	---	---
	0.79	---	---	---	---	---	---	---
	1.18	---	---	---	---	---	---	---
	1.57	---	---	---	---	---	---	---
MP 18.1	0.59	as desired	VAW 80	111430100700	KL 50 for external clamping	111210300000	GSP 20/20 one-sided	111010100000
	0.71	as desired	VAW 80	111430100700	KL 50 for external clamping	111210300000	GSP 20/20	111010100000
	0.98	as desired	VAW 80	111430100700	KL 50 for external clamping	111210300000	GSP 20/20	111010100000
	1.46	as desired	VAW 80	111430100700	KL 50 for external clamping	111210300000	GSP 20/20	111010100000
	1.97	as desired	VAW 80	111430100700	KL 50 for external clamping	111210300000	GSP 20/20	111010100000
	2.76	as desired	VAW 80	111430100700	KL 50 for external clamping	111210300000	GSP 20/20	111010100000
MP 18.2	0.59	as desired	VAW 80	111430100700	KL 50 for external clamping	111210300000	GSP 20/20 one-sided	111010100000
	0.71	as desired	VAW 80	111430100700	KL 50 for external clamping	111210300000	GSP 20/20	111010100000
	0.98	as desired	VAW 80	111430100700	KL 50 for external clamping	111210300000	GSP 20/20	111010100000
	1.46	as desired	VAW 80	111430100700	KL 50 for external clamping	111210300000	GSP 20/20	111010100000
	1.97	as desired	VAW 80	111430100700	KL 50 for external clamping	111210300000	GSP 20/20	111010100000
	2.76	as desired	VAW 80	111430100700	KL 50 for external clamping	111210300000	GSP 20/20	111010100000
MP 3001	1.02	up to 95	VAW 80	111430100700	DBP 3001 for internal clamping	111212100000	GSP 20/20	111010100000
					KL 50 for external clamping	111210300000	GSP 20/20	111010100000
	4.72 up to 5.91 inch	VAW 122	VAWK-120	111440100700	KL 50	111210300000	GSP 20/20	111010100000
					WHK-120	111210400000	GSP 20/20	111010100000
					KL 50	111210300000	GSP 20/20	111010100000
7.87 inch	VAW 150	111470100700	KL 50	111210300000	GSP 20/20	111010100000		
11.81 inch	VAW 248	111480100700	KL 50	111210300000	GSP 5/15	111010180000		

Type	Inside width	Radius	Radius channel	Guide channel	Order no.	Fastening	Order no.	Glide rail	Order no.			
MP 3002	1.46	up to 3.74	VAW 80	111430100700	DBP 3002 for internal clamping	111212120000	GSP 20/20	111010100000				
						KL 50 for external clamping	111210300000	GSP 20/20	111010100000			
					4.72–5.91		VAW 122	111440100700	KL 50	111210300000	GSP 20/20	111010100000
							VAWK-120	111490100700	WHK-120	111210400000	GSP 20/20	111010100000
					7.87	VAW 150	111470100700	KL 50	111210300000	GSP 20/20	111010100000	
11.81	VAW 248	111480100700	KL 50	111210300000	GSP 5/15	111010180000						
MP 3002.5	2.20	up to 95	VAW 80	111430100700	DBP 3002.5 for internal clamping	111212130000	GSP 20/20	111010100000				
						KL 50 for external clamping	111210300000	GSP 20/20	111010100000			
					4.72–5.91		VAWK-120	111490100700	WHK-120	111210400000	GSP 20/20	111010100000
							VAW 122	111440100700	KL 50	111210300000	GSP 20/20	111010100000
					7.87	VAW 150	111470100700	KL 50	111210300000	GSP 20/20	111010100000	
11.81	VAW 248	111480100700	KL 50	111210300000	GSP 5/15	111010180000						
MP 3003	2.44	up to 95	VAW 80	111430100700	DBP 3003/35062 for internal clamping	111212140000	GSP 20/20	111010100000				
						KL 50 for external clamping	111210300000	GSP 20/20	111010100000			
					4.72–5.91		VAW 122	111440100700	KL 50	111210300000	GSP 20/20	111010100000
							VAWK-120	111490100700	WHK-120	111210400000	GSP 20/20	111010100000
					7.87	VAW 150	111470100700	KL 50	111210300000	GSP 20/20	111010100000	
11.81	VAW 248	111480100700	KL 50	111210300000	GSP 5/15	111010180000						
MP 3003.5	2.99	up to 95	VAW 80	111430100700	DBP 3003.5 for internal clamping	111212150000	GSP 20/20	111010100000				
						KL 50 for external clamping	111210300000	GSP 20/20	111010100000			
					4.72–5.91		VAW 122	111440100700	KL 50	111210300000	GSP 20/20	111010100000
							VAWK-120	111490100700	WHK-120	111210400000	GSP 20/20	111010100000
					7.87	VAW 150	111470100700	KL 50	111210300000	GSP 20/20	111010100000	
11.81	VAW 248	111480100700	KL 50	111210300000	GSP 5/15	111010180000						



Selecting gliding variable guide channels

Type	Inside width	Radius	Guide channel	Order no.	Fastening	Order no.	Glide rail	Order no.
MP 3004	3.43	up to 3.74	VAW 80	111430100700	DBP 3004/35086 for internal clamping	111212160000	GSP 20/20	111010100000
					KL 50 for external clamping	111210300000	GSP 20/20	111010100000
	4.72 –5.91	VAW 122	111440100700	KL 50	111210300000	GSP 20/20	111010100000	
				VAWK-120	111490100700	WHK-120	111210400000	GSP 20/20
	7.87	VAW 150	111470100700	KL 50	111210300000	GSP 20/20	111010100000	
	11.81	VAW 248	111480100700	KL 50	111210300000	GSP 5/15	111010180000	
MP 3005	3.98	up to 3.74	VAW 80	111430100700	DBP 3005/35102 for internal clamping	111212180000	GSP 20/20	111010100000
					KL 50 for external clamping	111210300000	GSP 20/20	111010100000
	4.72 –5.91	VAW 122	111440100700	KL 50	111210300000	GSP 20/20	111010100000	
				VAWK-120	111490100700	WHK-120	111210400000	GSP 20/20
	7.87	VAW 150	111470100700	KL 50	111210300000	GSP 20/20	111010100000	
	11.81	VAW 248	111480100700	KL 50	111210300000	GSP 5/15	111010180000	
MP 3006	4.92	up to 3.74	VAW 80	111420100700	2 x DBP 3001 for internal clamping	111212180000	GSP 20/20	111010100000
					KL 50 for external clamping	111210300000	GSP 20/20	111010100000
	4.72 –5.91	VAW 122	111440100700	KL 50	111210300000	GSP 20/20	111010100000	
				VAWK-120	111490100700	WHK-120	111210400000	GSP 20/20
	7.87	VAW 150	111470100700	KL 50	111210300000	GSP 20/20	111010100000	
	11.81	VAW 248	111480100700	KL 50	111210300000	GSP 5/15	111010180000	
MP 25026 G	1.02	up to 3.94	VAW 80	111430100700	DBP 3001 for internal clamping	111212100000	GSP 20/20	111010100000
					KL 50 for external clamping	111210300000	GSP 20/20	111010100000
	4.92 –5.91	VAW 122	111440100700	KL 50	111210300000	GSP 20/20	111010100000	
				7.87	VAW 150	111470100700	KL 50	111210300000
	9.84	VAW 177	111450100700	KL 50	111210300000	GSP 20/20	111010100000	

Type	Inside width	Radius	Guide channel	Order no.	Fastening	Order no.	Glide rail	Order no.
MP 25037 G	1.46	up to 3.94	VAW 80	111430100700	DBP 3002 for internal clamping	111212100000	GSP 20/20	111212120000
					KL 50 for external clamping	111210300000		
		4.92–5.91	VAW 122	111440100700	KL 50	111210300000	GSP 20/20	111010100000
			VAW 150	111470100700	KL 50	111210300000	GSP 20/20	111010100000
			VAW 177	111450100700	KL 50	111210300000	GSP 20/20	111010100000
MP 25062 G	2.44	up to 3.94	VAW 80	111430100700	DBP 3003/35062 for internal clamping	111212140000	GSP 20/20	111010100000
					KL 50 for external clamping	111210300000		
		4.92–5.91	VAW 122	111440100700	KL 50	111210300000	GSP 20/20	111010100000
			VAW 150	111470100700	KL 50	111210300000	GSP 20/20	111010100000
			VAW 177	111450100700	KL 50	111210300000	GSP 20/20	111010100000
MP 25087 G	3.43	up to 3.94	VAW 80	111430100700	DBP 3004/35086 for internal clamping	111212160000	GSP 20/20	111010100000
					KL 50 for external clamping	111210300000		
		4.92–5.91	VAW 122	111440100700	KL 50	111210300000	GSP 20/20	111010100000
			VAW 150	111470100700	KL 50	111210300000	GSP 20/20	111010100000
			VAW 177	111450100700	KL 50	111210300000	GSP 20/20	111010100000
MP 25101 G	3.98	up to 3.94	VAW 80	111430100700	DBP 3005/35102 for internal clamping	111212180000	GSP 20/20	111010100000
					KL 50 for external clamping	111210300000		
		4.92–5.91	VAW 122	111440100700	KL 50	111210300000	GSP 20/20	111010100000
			VAW 150	111470100700	KL 50	111210300000	GSP 20/20	111010100000
			VAW 177	111450100700	KL 50	111210300000	GSP 20/20	111010100000
MP 25125 G	4.92	up to 3.94	VAW 80	111430100700	DBP 3001 for internal clamping	111212100000	GSP 20/20	111010100000
					KL 50 for external clamping	111210300000		
		4.92–5.91	VAW 122	111440100700	KL 50	111210300000	GSP 20/20	111010100000
			VAW 150	111470100700	KL 50	111210300000	GSP 20/20	111010100000
			VAW 177	111450100700	KL 50	111210300000	GSP 20/20	111010100000



Selecting gliding variable guide channels

Type	Inside width	Radius	Guide channel	Order no.	Fastening	Order no.	Glide rail	Order no.
MP 32	as desired	up to 5.91	VAW 122	111440100700	KL 50	111210300000	GSP 20/24	111010140000
		7.87–9.84	VAW 177	111450100700	KL 50	111210300000	GSP 20/24	111010140000
MP 32.2	as desired	up to 5.91	VAW 122	111440100700	KL 50	111210300000	GSP 20/24	111010140000
		7.87–9.84	VAW 177	111450100700	KL 50	111210300000	GSP 20/24	111010140000
MP 32.3	as desired	up to 5.91	VAW 122	111440100700	KL 50	111210300000	GSP 20/24	111010140000
		7.87–9.84	VAW 177	111450100700	KL 50	111210300000	GSP 20/24	111010140000
MP 35	2.44	up to 3.94	VAW 80	111430100700	DBP 3003/35062 for internal clamping	111212140000	GSP 20/20	111010100000
						KL 50 for external clamping	111210300000	GSP 20/20
		5.91	VAW 122	111440100700	KL 50	111210300000	GSP 20/20	111010100000
		7.87	VAW 150	111470100700	KL 50	111210300000	GSP 20/20	111010100000
		11.81	VAW 248	111480100700	KL 50	111210300000	GSP 5/15	111010180000
		3.39	up to 3.94	VAW 80	111430100700	DBP 3004/35086 for internal clamping	111212160000	GSP 20/20
						KL 50 for external clamping	111210300000	GSP 20/20
	5.91		VAW 122	111440100700	KL 50	111210300000	GSP 20/20	111010100000
	7.87		VAW 150	111470100700	KL 50	111210300000	GSP 20/20	111010100000
	11.81		VAW 248	111480100700	KL 50	111210300000	GSP 5/15	111010180000
	4.02		up to 3.94	VAW 80	111430100700	DBP 3005/35102 for internal clamping	111212180000	GSP 20/20
						KL 50 for external clamping	111210300000	GSP 20/20
5.91		VAW 122	111440100700	KL 50	111210300000	GSP 20/20	111010100000	
7.87		VAW 150	111470100700	KL 50	111210300000	GSP 20/20	111010100000	
11.81		VAW 248	111480100700	KL 50	111210300000	GSP 5/15	111010180000	
4.92		up to 3.94	VAW 80	111430100700	2 x DBP 3001 for internal clamping	111212100000	GSP 20/20	111010100000
					KL 50 for external clamping	111210300000	GSP 20/20	111010100000
	5.91	VAW 122	111440100700	KL 50	111210300000	GSP 20/20	111010100000	
	7.87	VAW 150	111470100700	KL 50	111210300000	GSP 20/20	111010100000	
	11.81	VAW 248	111480100700	KL 50	111210300000	GSP 5/15	111010180000	

Type	Inside width	Radius	Guide channel	Order no.	Fastening	Order no.	Glide rail	Order no.		
MP 35	5.91	up to 3.94	VAW 80	111430100700	2 x DBP 3001 for internal clamping	111212100000	GSP 20/20	111010100000		
					KL 50 for external clamping	111210300000	GSP 20/20	111010100000		
					VAW 122	111440100700	KL 50	111210300000	GSP 20/20	111010100000
					VAW 150	111470100700	KL 50	111210300000	GSP 20/20	111010100000
					VAW 248	111480100700	KL 50	111210300000	GSP 5/15	111010180000
MP 36062 G	2.44	up to 3.94	VAW 80	111430100700	DBP 3003/35062 for internal clamping	111212140000	GSP 20/20	111010100000		
					KL 50 for external clamping	111210300000	GSP 20/20	111010100000		
					VAW 122	111440100700	KL 50	111210300000	GSP 20/20	111010100000
					VAW 150	111470100700	KL 50	111210300000	GSP 20/20	111010100000
					MP 36086 G	3.39	up to 3.94	VAW 80	111430100700	DBP 3004/35086 for internal clamping
					KL 50 for external clamping	111210300000	GSP 20/20	111010100000		
		5.91	VAW 122	111440100700	KL 50	111210300000	GSP 20/20	111010100000		
		7.87	VAW 150	111470100700	KL 50	111210300000	GSP 20/20	111010100000		
MP 36102 G	4.02	up to 3.94	VAW 80	111430100700	DBP 3005/35102 for internal clamping	111212180000	GSP 20/20	111010100000		
					KL 50 for external clamping	111210300000	GSP 20/20	111010100000		
					VAW 122	111440100700	KL 50	111210300000	GSP 20/20	111010100000
					VAW 150	111470100700	KL 50	111210300000	GSP 20/20	111010100000
					MP 36125 G	4.92	up to 3.94	VAW 80	111430100700	2 x DBP 3001 for internal clamping
KL 50 for external clamping	111210300000	GSP 20/20	111010100000							
VAW 122	111440100700	KL 50	111210300000	GSP 20/20						111010100000
VAW 150	111470100700	KL 50	111210300000	GSP 20/20						111010100000
MP 44	as desired	up to 5.91	VAW 122	111440100700						KL 50
					VAW 150	111470100700	KL 50	111210300000	GSP 20/20	111010100000
					VAW 177	111450100700	KL 50	111210300000	GSP 20/20	111010100000



Selecting gliding variable guide channels

Type	Inside width	Radius	Guide channel	Order no.	Fastening	Order no.	Glide rail	Order no.
MP 43 G	as desired	up to 5.91	VAW 122	111440100700	KL 50	111210300000	GSP 20/20	111010100000
		7.87	VAW 150	111470100700	KL 50	111210300000	GSP 20/20	111010100000
		9.84	VAW 177	111450100700	KL 50	111210300000	GSP 20/20	111010100000
MP 41	as desired	up to 5.91	VAW 122	111440100700	KL 50	111210300000	GSP 20/20	111010100000
		7.87	VAW 150	111470100700	KL 50	111210300000	GSP 20/20	111010100000
		9.84	VAW 177	111450100700	KL 50	111210300000	GSP 20/20	111010100000
		11.81	VAW 248	111480100700	KL 50	111210300000	GSP 5/15	111010180000
MP 41.2	as desired	up to 5.91	VAW 122	111440100700	KL 50	111210300000	GSP 20/20	111010100000
		7.87	VAW 150	111470100700	KL 50	111210300000	GSP 20/20	111010100000
		9.84	VAW 177	111450100700	KL 50	111210300000	GSP 20/20	111010100000
		11.81	VAW 248	111480100700	KL 50	111210300000	GSP 5/15	111010180000
MP 41.3 G	as desired	up to 5.91	VAW 122	111440100700	KL 50	111210300000	GSP 20/20	111010100000
		7.87	VAW 150	111470100700	KL 50	111210300000	GSP 20/20	111010100000
		9.84	VAW 177	111450100700	KL 50	111210300000	GSP 20/20	111010100000
		11.81	VAW 248	111480100700	KL 50	111210300000	GSP 5/15	111010180000
MP 52.1	as desired	up to 5.91	VAW 122	111440100700	KL 50	111210300000	GSP 20/29	111010120000
		7.87–9.84	VAW 177	111450100700	KL 50	111210300000	GSP 20/29	111010120000
		11.81	VAW 248	111480100700	KL 50	111210300000	GSP 5/15	111010180000
MP 52.2	as desired	up to 5.91	VAW 122	111440100700	KL 50	111210300000	GSP 20/29	111010120000
		7.87–9.84	VAW 177	111450100700	KL 50	111210300000	GSP 20/29	111010120000
		11.81	VAW 248	111480100700	KL 50	111210300000	GSP 5/15	111010180000
MP 52.3	as desired	up to 5.91	VAW 122	111440100700	KL 50	111210300000	GSP 20/29	111010120000
		7.87–9.84	VAW 177	111450100700	KL 50	111210300000	GSP 20/29	111010120000
		11.81	VAW 248	111480100700	KL 50	111210300000	GSP 5/15	111010180000

Type	Inside width	Radius	Guide channel	Order no.	Fastening	Order no.	Glide rail	Order no.
MP 66	as desired	up to 9.45	VAW 177	111450100700	KL 50	111210300000	GSP 20/20	111010100000
		11.02–13.78	VAW 248	111480100700	KL 50	111210300000	GSP 9/11	111010220000
MP 65 G	as desired	up to 9.45	VAW 177	111450100700	KL 50	111210300000	GSP 20/20	111010100000
		11.02–13.78	VAW 248	111480100700	KL 50	111210300000	GSP 9/11	111010220000
MP 62.1	as desired	up to 9.84	VAW 177	111450100700	KL 50	111210300000	GSP 20/29	111010120000
		11.81–19.69	VAW 248	111480100700	KL 50	111210300000	GSP 7/13	111010200000
MP 62.2	as desired	up to 9.84	VAW 177	111450100700	KL 50	111210300000	GSP 20/29	111010120000
		11.81–19.69	VAW 248	111480100700	KL 50	111210300000	GSP 7/13	111010200000
MP 62.3	as desired	up to 9.84	VAW 177	111450100700	KL 50	111210300000	GSP 20/29	111010120000
		11.81–19.69	VAW 248	111480100700	KL 50	111210300000	GSP 7/13	111010200000
MP 72	as desired	up to 19.69	VAW 248	111480100700	KL 50	111210300000	GSP 9/11	111010220000
MP 82.2	as desired	up to 19.69	VAW 248	111480100700	KL 50	111210300000	GSP 7/13	111010200000
MP 82.3 G	as desired	up to 19.69	VAW 248	111480100700	KL 50	111210300000	GSP 7/13	111010200000
MP 102.2	as desired	up to 19.69	VAW MT 248	111480140700	KL 50	111210300000	GSP 33/9	111010240000

VAW standard delivery length 6.56 ft (2 m). Also available in 16.40 ft (5 m) length by request. Please state the length of your channel system in your order.



Simple, quick and secure installation ...

... of the Murrplastik guide channel.

The combination of the groove system on the individual aluminum channel sides and the glide rail sections forms an extremely variable guide channel system which provides a safe, stable and very attractive chain guide system requiring few accessories.

The glide rails are simply pushed into the groove provided in the aluminum section. The only fastening required is a screw at the beginning and the end of the last glide rail.

It is incredibly simple to install the channel. Special clamping pieces are used to secure the system in the desired position. The channel sections are perfectly aligned thanks to special plastic longitudinal connectors which are placed in a groove specially provided for that purpose.

There are no welded seams or screw parts jutting out into the chain's area of movement with the Murrplastik guide channel system.

The use of highly durable aluminum eliminates the need for any corrosion prevention.

Economic solution

The use of standard components reduces costs in this case. Design and manufacture are entirely taken care of. Other methods of producing guide channels involve the following:

- Measuring and drawing the installation
- Obtaining the various components
- Cutting the plate to size
- Punching the plate
- Plate-edge bending
- Drilling the attachment holes
- Mounting the channel
- Welding and sanding down channel connections
- Lacquering

When the costs of the components and assembly time are added together, it soon becomes apparent that the Murrplastik VAW system is a very cost effective solution.

Channel clearance (SP) at variable jam

Chain type	Clearance (SP) up to inch
All chain types with MMT magnet chain technology	max. 0.16
MP 18.x	0.24
MP 25 G MP 3000 MP 35 MP 36 G	0.31
MP 32.x MP 41.x MP 43 G MP 44 MP 52.x MP 62.x MP 65 G MP 66 MP 72	0.47
MP 82.x MP 102.x	0.63

As a general rule, there must be sufficient clearance between the guide channel and the chain to prevent the chain from ever jamming in the guide channel. The clearance must be at least 0.08 in (2 mm) less than the width of the sideband of the chain link, otherwise the chain will not glide properly and this will lead to problems over time.

Positioning glide rail

VAW 80

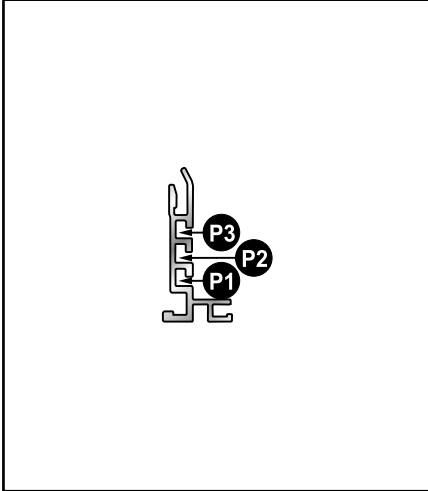

GSP 20/20

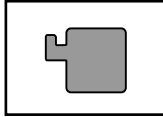

Item

1	MP 18.1	MP 18.2
2	MP 25 G	MP 3000
3	MP 35	MP 36 G

VAW 122

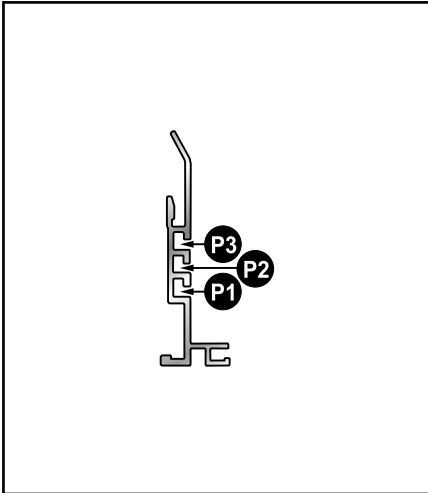

GSP 20/20

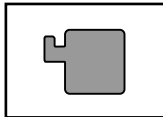

Item

1	MP 25 G	MP 3000
2	MP 35	MP 36 G
3	MP 41.x	MP 43 G MP 44

GSP 20/24

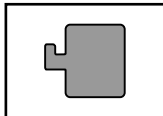

Item

2	MP 32.x
3	MP 41.x

GSP 20/29

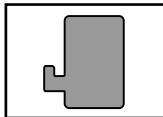

Item

3	MP 52.x
---	---------

VAW 150

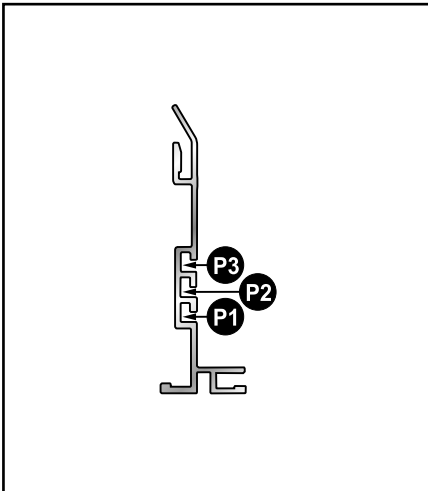

GSP 20/20

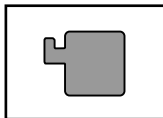

Item

1	MP 25 G	MP 3000
2	MP 35	MP 36 G
3	MP 41.x	MP 43 G MP 44

GSP 20/24

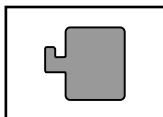

Item

2	MP 32.x
---	---------



Positioning glide rail

VAW 177/VAW MT 177

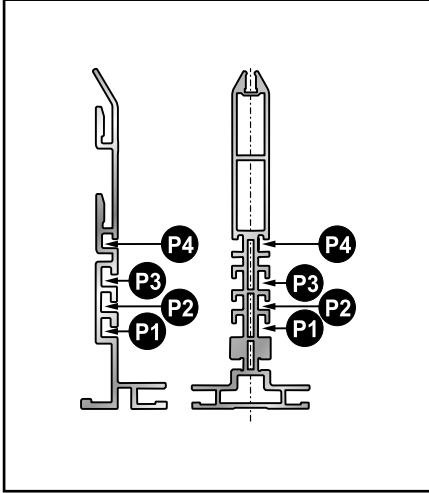

GSP 20/20

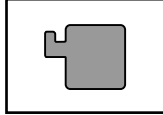

GSP 20/24

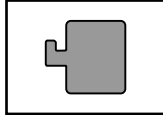

Item

1	MP 25 G		
2	MP 35	MP 35 G	
3	MP 41.x	MP 43 G	MP 44
4	MP 65 G	MP 66	

Item

2	MP 32.x
3	MP 52.x
4	MP 62.x

VAW 248/VAW MT 248

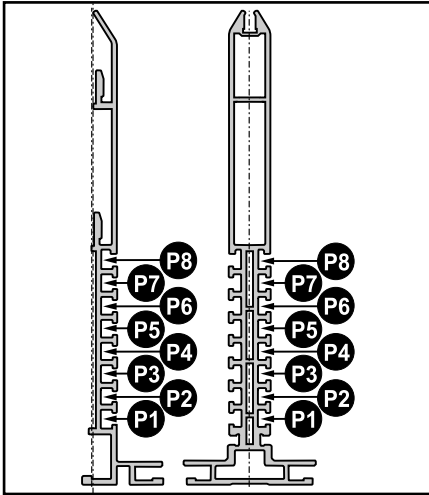

GSP 5/15

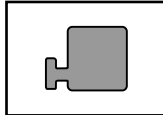

GSP 7/13

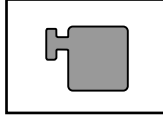

GSP 9/11

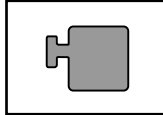

GSP 33/9

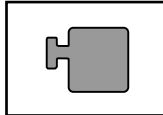

Item

1	MP 25 G	MP 3000
2	MP 36 G	
3		
4	MP 41.x	MP 44 MP 43 G
5	MP 52.x	

Item

3	MP 32.x
5	MP 62.x
8	MP 82.x

Item

5	MP 66	MP 65 G
7	MP 72	

Item

8	MP 102.2
---	----------

Fastening of VAW guide channel with DBP distance plate

Internal clamping VAW 25 guide channel with distance spacer plate DBP

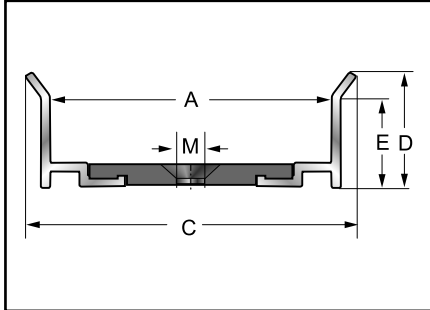

Guide channel	Fastening	Dimension in inch			
		A	C	D	E
VAW 25	DBP 14016	0.98	1.42	1.02	0.79
VAW 25	DBP 14020/18015/18018	0.98	1.61	1.22	0.79
VAW 25	DBP 14030/18025	0.98	1.93	1.54	0.79
VAW 25	DBP 14040/18037	0.98	2.36	1.97	0.79
VAW 25	DBP 14050/18050	0.98	2.91	2.52	0.79
VAW 25	DBP 18070	0.98	3.70	3.31	0.79

Internal clamping VAW 35 guide channel with distance spacer plate DBP

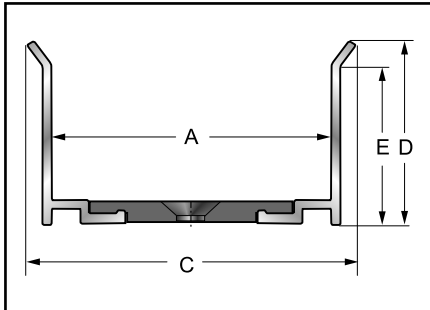

Guide channel	Fastening	Dimension in inch			
		A	C	D	E
VAW 35	DBP 3001	1.81	2.20	1.38	1.18
VAW 35	DBP 3002	2.36	2.76	1.38	1.18
VAW 35	DBP 3002.5	3.11	3.50	1.38	1.18
VAW 35	DBP 3003.5	3.90	4.29	1.38	1.18
VAW 35	DBP 3003/35062	3.31	3.70	1.38	1.18
VAW 35	DBP 3004/35086	4.33	4.57	1.38	1.18
VAW 35	DBP 3005/35102	4.96	5.16	1.38	1.18

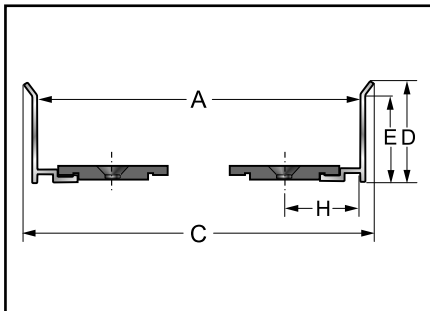

Guide channel	Fastening	Dimension in inch	
		D	E
VAW 35	2 x DBP 3001	1.38	1.18

A = External width of chain + channel clearance
C = External width of chain + channel clearance + 0.94 in (24 mm)

Internal clamping VAW 80 guide channel with distance spacer plate DBP

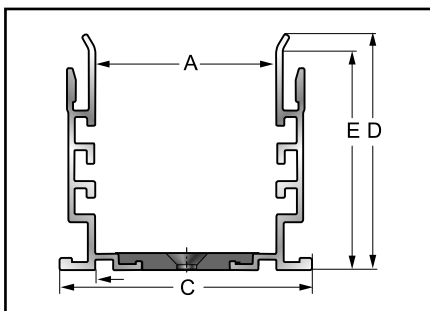

Guide channel	Fastening	Dimension in inch			
		A	C	D	E
VAW 80	DBP 3001	1.81	2.76	3.15	2.91
VAW 80	DBP 3002	2.36	3.31	3.15	2.91
VAW 80	DBP 3002.5	3.11	4.06	3.15	2.91
VAW 80	DBP 3003.5	3.31	4.25	3.15	2.91
VAW 80	DBP 3003/35062	3.90	4.84	3.15	2.91
VAW 80	DBP 3004/35086	4.33	5.12	3.15	2.91
VAW 80	DBP 3005/35102	4.96	5.71	3.15	2.91



Fastening VAW guide channel with clamping piece KL 50

VAW 80 Guide channel

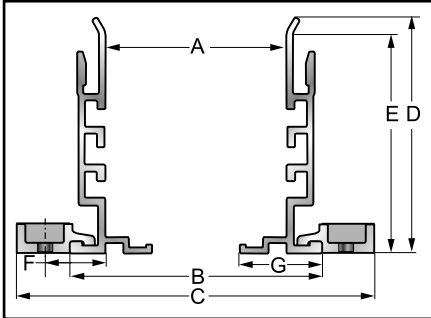

Clear width	
A	= External width of chain + channel clearance
External width guide channel	
B	= External width of chain + channel clearance + 1.18 in (30 mm)
External width for external clamping with KL 50	
C	= External width of chain + channel clearance + 2.99 in (76 mm)
D	= 3.15 in (80 mm)
E	= 2.91 in (74 mm)
F	= 0.93 in (23.5 mm)
G	= 1.38 in (35 mm)

VAW 122 Guide channel

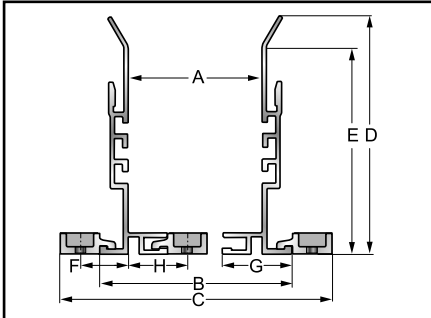

Clear width	
A	= External width of chain + channel clearance
External width for internal clamping with KL 50	
B	= External width of chain + channel clearance + 1.18 in (30 mm)
External width for external clamping with KL 50	
C	= External width of chain + channel clearance + 2.99 in (76 mm)
D	= 4.80 in (122 mm)
E	= 4.13 in (105 mm)
F	= 0.93 in (23.5 mm)
G	= 1.38 in (35 mm)
H	= 1.24 in (31.5 mm)

VAW 150 Guide channel

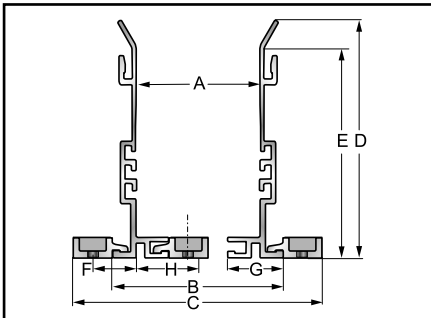

Clear width	
A	= External width of chain + channel clearance
External width for internal clamping with KL 50	
B	= External width of chain + channel clearance + 1.18 in (30 mm)
External width for external clamping with KL 50	
C	= External width of chain + channel clearance + 2.99 in (76 mm)
D	= 5.91 in (150 mm)
E	= 5.24 in (133 mm)
F	= 0.93 in (23.5 mm)
G	= 1.38 in (35 mm)
H	= 1.24 in (31.5 mm)

VAW 177 Guide channel

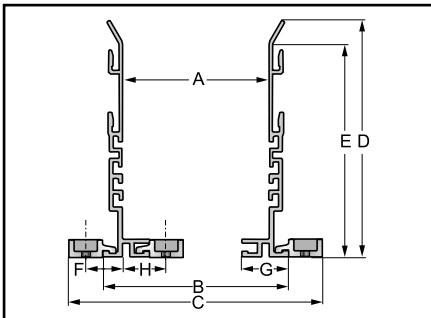

Clear width	
A	= External width of chain + channel clearance
External width for internal clamping with KL 50	
B	= External width of chain + channel clearance + 1.18 in (30 mm)
External width for external clamping with KL 50	
C	= External width of chain + channel clearance + 2.99 in (76 mm)
D	= 6.97 in (177 mm)
E	= 6.30 in (160 mm)
F	= 0.93 in (23.5 mm)
G	= 1.38 in (35 mm)
H	= 1.24 in (31.5 mm)

Fastening VAW guide channel with clamping piece KL 50

VAW-MT 177 Guide channel

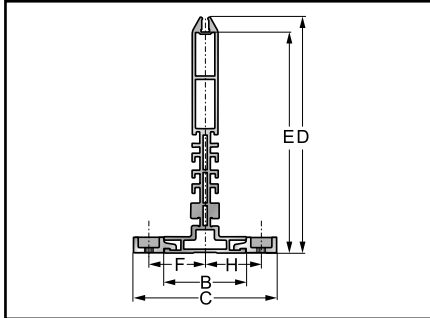

Clamping with KL 50 clamping piece

B	=	2.44 in (62 mm)
C	=	4.25 in (108 mm)
D	=	6.97 in (177 mm)
E	=	6.30 in (160 mm)
F	=	1.67 in (42.5 mm)
H	=	1.67 in (42.5 mm)

VAW 248 Guide channel

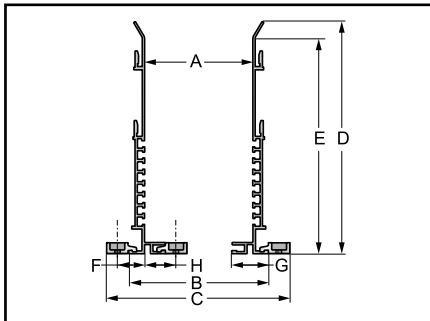

Clear width

A = External width of chain + channel clearance

External width for internal clamping with KL 50

B = External width of chain + channel clearance + 1.18 in (30 mm)

External width for external clamping with KL 50

C = External width of chain + channel clearance + 2.99 in (76 mm)

D	=	6.97 in (177 mm)
E	=	6.30 in (160 mm)
F	=	0.93 in (23.5 mm)
G	=	1.38 in (35 mm)
H	=	1.24 in (31.5 mm)

VAW-MT 248 Guide channel

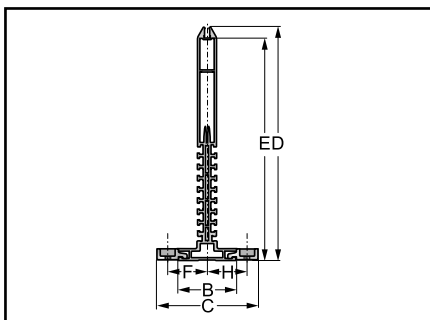

Clamping with KL 50 clamping piece

B	=	2.44 in (62 mm)
C	=	4.25 in (108 mm)
D	=	9.76 in (248 mm)
E	=	9.29 in (236 mm)
F	=	1.67 in (42.5 mm)
H	=	1.67 in (42.5 mm)

Guide channel VAWK

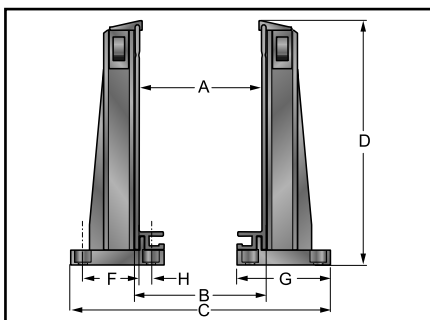

Clamping with WHK-120

A = External width of chain + channel clearance

External width for internal clamping with WHK-120

B = External width of chain + channel clearance + 0.20 in (5 mm)

External width for external clamping with WHK-120

C = External width of chain + channel clearance + 4.27 in (108.5 mm)

D	=	5.79 in (147 mm)
F	=	1.93 in (49 mm)
G	=	2.76 in (70.2 mm)
H	=	0.16 in (4 mm)



Dimension table VAW guide channel

Distance fixing plate DBP 14016

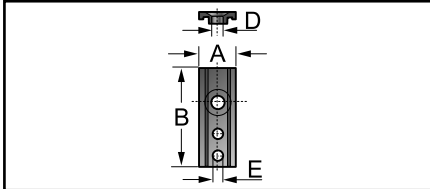

Dimensions in inch					
A	B	C	D	E	F
0.55	1.46	---	0.20	0.17	---

Distance fixing plate DBP 14020/18018/18015

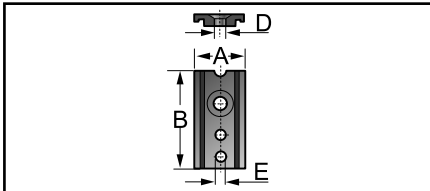

Dimensions in inch					
A	B	C	D	E	F
0.74	1.46	---	0.20	0.17	---

Distance fixing plate DBP 14030/18025

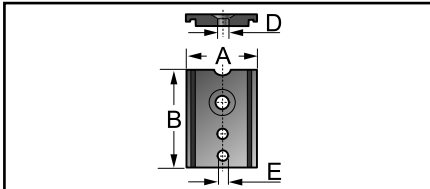

Dimensions in inch					
A	B	C	D	E	F
1.07	1.46	---	0.20	0.17	---

Distance fixing plate DBP 14040/18037

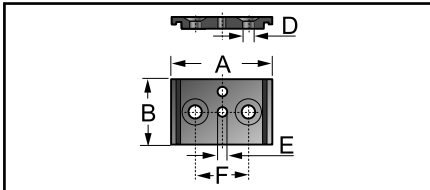

Dimensions in inch					
A	B	C	D	E	F
1.50	0.98	---	0.20	0.14	0.79

Distance fixing plate DBP 14050/18050

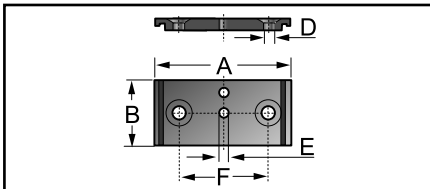

Dimensions in inch					
A	B	C	D	E	F
51.7	0.98	---	0.20	0.14	1.34

Dimension table VAW guide channel

Distance fixing plate DBP 18070

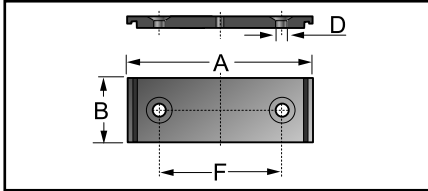

Dimensions in inch					
A	B	C	D	E	F
2.83	0.98	---	0.20	---	1.89

Distance fixing plate DBP 3001

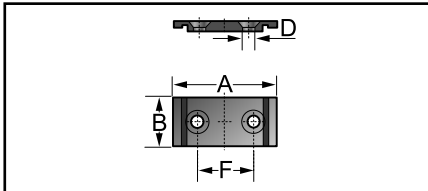

Dimensions in inch					
A	B	C	D	E	F
1.18	1.57	---	0.24	0.26	---

Distance fixing plate DBP 3002

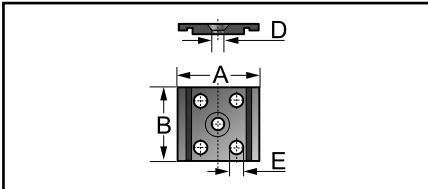

Dimensions in inch					
A	B	C	D	E	F
1.71	1.57	---	0.24	0.26	---

Distance fixing plate DBP 3002.5

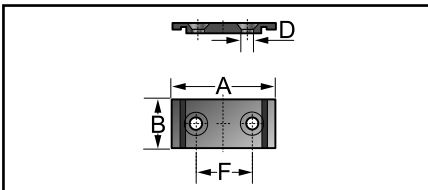

Dimensions in inch					
A	B	C	D	E	F
2.44	1.18	---	0.24	---	1.34

Distance fixing plate DBP 3003/35062

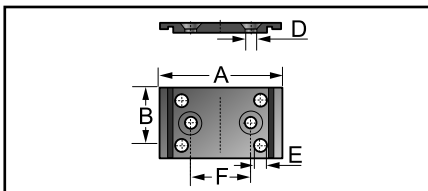

Dimensions in inch					
A	B	C	D	E	F
2.68	1.57	---	0.24	0.26	1.34



Dimension table VAW guide channel

Distance fixing plate DBP 3003.5

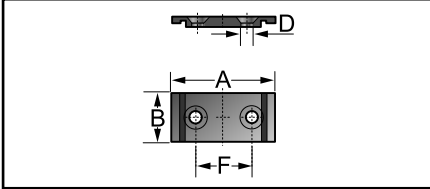

Dimensions in inch					
A	B	C	D	E	F
3.23	1.18	---	0.24	---	1.97

Distance fixing plate DBP 3004/35086

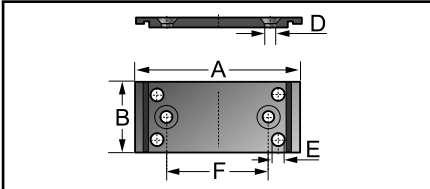

Dimensions in inch					
A	B	C	D	E	F
3.68	1.57	---	0.24	0.26	2.30

Distance fixing plate DBP 3005/35102

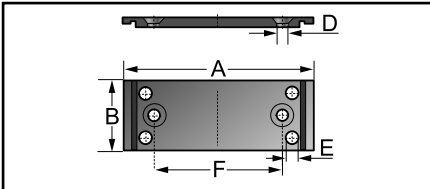

Dimensions in inch					
A	B	C	D	E	F
4.31	1.57	---	0.24	0.26	2.89

Clamping piece KL 50

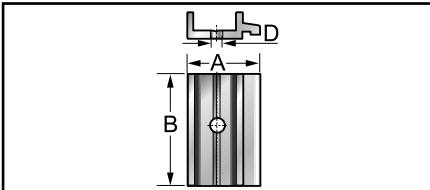

Dimensions in inch					
A	B	C	D	E	F
1.28	1.97	---	0.24	---	---

Clamping piece WHK-120

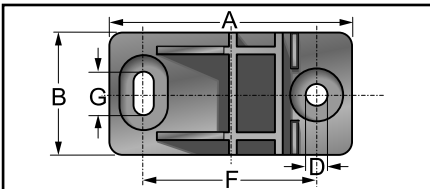

Dimensions in inch					
A	B	C	D	F	G
2.76	1.38	0.26	0.24	5/16	0.47

STRAIN RELIEF SYSTEMS

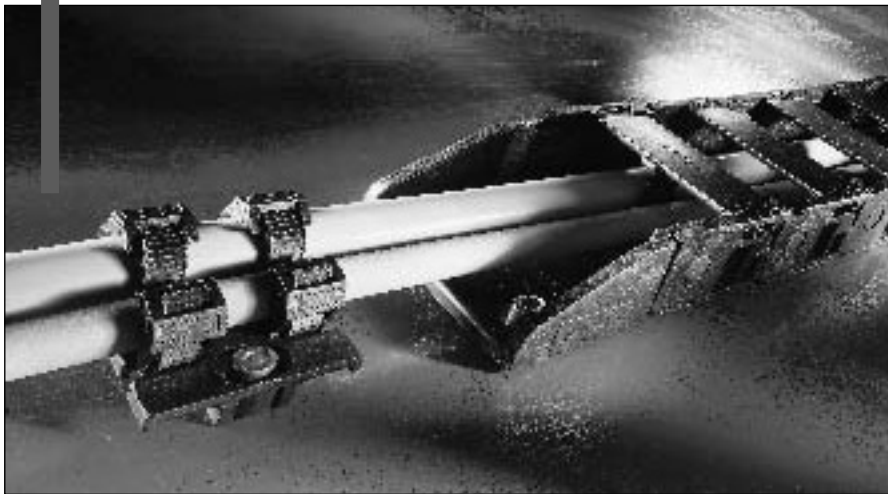



The ZL strain relief plate is used to securely hold cables on machines and other installations.

The cables are held on either side of the plate tongue with wide bodied type KB 28 cable ties.

The undercut on the tongues prevent the cable ties from slipping off, even when the cable diameter is larger than the plate tongue itself. The use of the ZL plate, and two wide ties for each cable, is ideal.

Wide, highly flexible power cable ties increase the surface pressure and ensure longer service life. When using a shelf system, two plates are installed on top of each other. DH distance bushes are used to this end. Washers come delivered with the strain relief plates. However, we do recommend our ELB insert bushing. This prevents the cold flowing of the plastic. The ZL strain relief plates should be mounted at a minimum distance of 20 to 30x the cable diameter from where the cable bends.



Durable fastening with metal bush

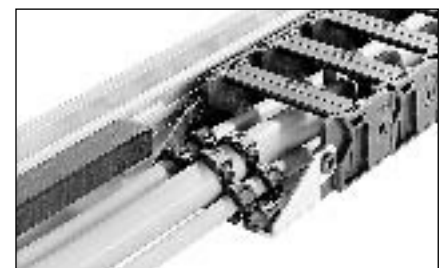

Strain relief plate mounted in chain mounting bracket.



Strain relief system advantages

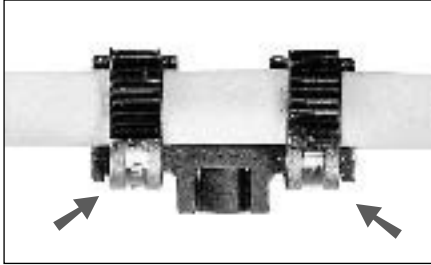

1.

Secure hold

The undercut on the underside of the plate prevents the cable tie from slipping off – even in the case of very large cable diameters.

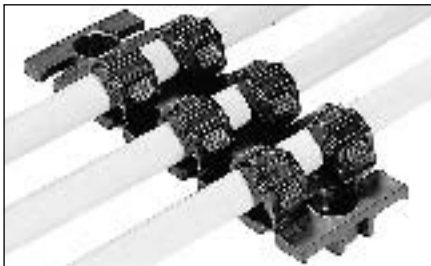

2.

Longer life

Each cable is secured by 2 wide cable ties on each end. This spreads the pressure on the cable and thereby minimizes the risk of damage to the cable core.



3.

Wide support face on the individual plate tongues

The cables are optimally secured by the wide supporting surfaces of the individual strain relief tongues. The wide power cable ties help to facilitate strain relief which is quick and simple but gentle on the cables.

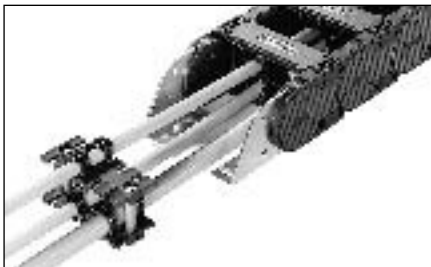

4.

2-tier installation

2-tier installation is possible by using the DH stand-offs.

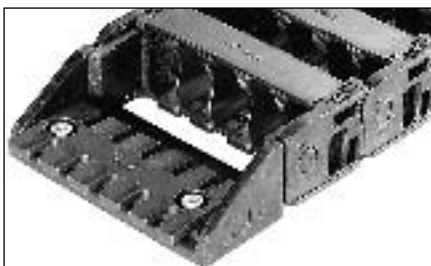

5.

Compatible fixing holes

The dimensions of the holes on the plates system match those on the chain brackets. **Please consider the dimension of the holes of the strain relief when it is mounted inside the chain bracket. (see page 358).**



6.

Durable fastening with metal bushing

The metal bushing inhibit cold flow properties. Metal is screwed onto metal. The screws are prevented from working loose. (Please order separately.)

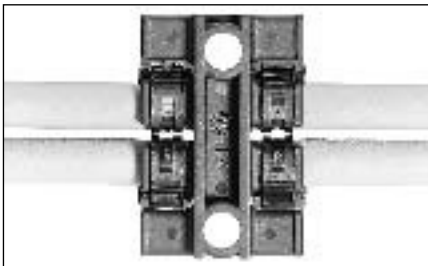

7.

Easy installation

Even if two cables are immediately next to each other, it is possible to secure them with two power cable ties.



8.

Different cable diameters

The flexible use of power cable ties provides strain relief which is quick and simple but very gentle on the cables, even for cables of very different diameters with extremely high packing density.



9.

Cost-effective solution

Suitable for laying cables on machines and installations.



Strain relief plate ZL

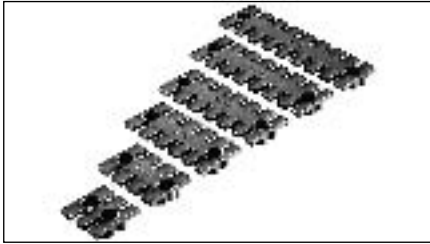

ZL...

Type	Order no.	Fits cable drag chain type	Pack
ZL 39	87701014	MP 25037G/MP 44045/MP 66045	1
ZL 60	87701016	MP 25062G/MP 35032/MP 36062/MP 43062 MP 44062 / MP 66062	1
ZL 80	87701015	MP 43082/MP 44082/MP 66082	1
ZL 87	87701018	MP 25087G/MP 35086/MP 36086	1
ZL 103	87701020	MP 25101G/MP 35102/MP 36102/MP 43107 MP 44107 / MP 66107	1
ZL 121	87701022	MP 25125G/MP 35125/MP 36125	1
ZL 140	87701024	MP 35150/MP 43142/MP 44142/MP 66142	1
ZL 180/6	87701026	MP 43182 / MP 44182	1
ZL 180/8	87701027	MP 66182	1

If the strain relief plate is to be fitted directly on the chain bracket, the hole dimensions of the strain relief plate should be taken as the basis.

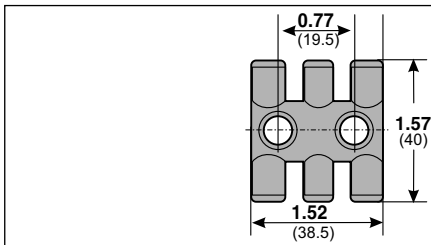

ZL 39

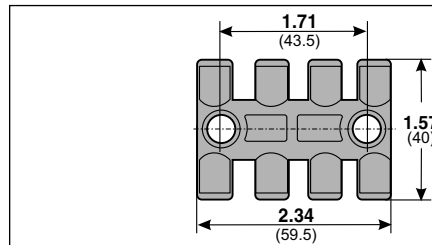

ZL 60

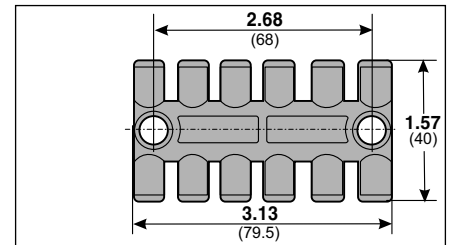

ZL 80

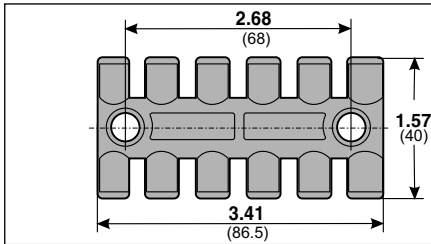

ZL 87

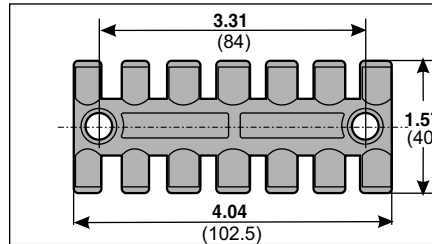

ZL 103

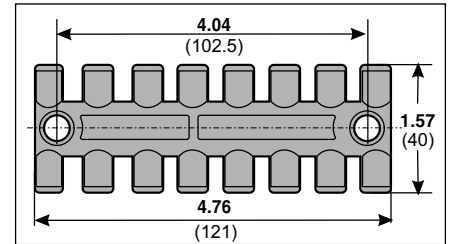

ZL 121

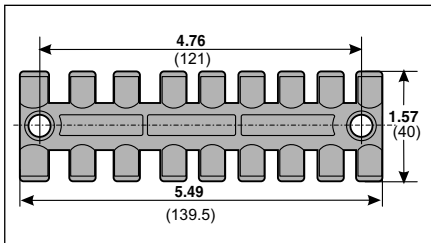

ZL 140

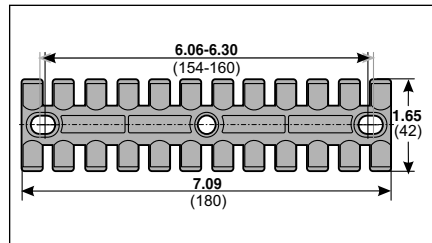

ZL 180/6

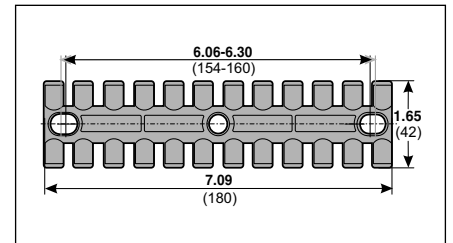

ZL 180/8

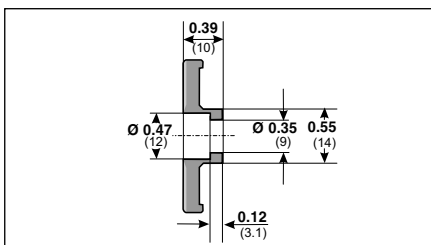

ZL 39-140

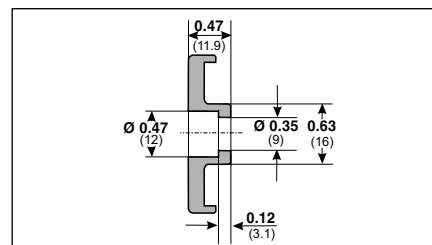

ZL 180/6

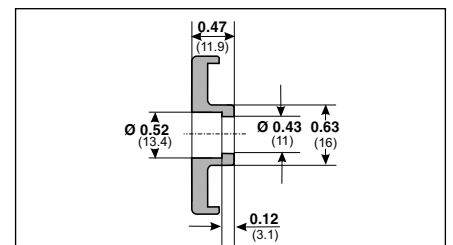

ZL 180/8

Murrplastik recommendations

The strain relief plate should be fitted with two power cable ties on each side of the cable and secured approx. 20 to 30 x cable diameter from the last moving chain link.

The strain relief is suitable for cables up to 1.57 in (40 mm) in diameter.

All electric cables must be relieved of strain at both the moving and fixed end. For longer travel distances (gliding application) a strain relief on one side at the moving end is recommended. Care must be taken to ensure the pressure only be applied to a wide surface of the cable outer jacket.

The clamping must be executed in such a way that the individual cores in the cable are not squashed, but the cable should still be held tightly.

Hydraulic and pneumatic conduits only have to be strain relieved at one end.

Double strain relief plates



Strain relief for the cables entered into the cable drag chain can also be achieved through a doubled setup using spacer sleeves. This variation of strain relief allows for an increased packing density.

Spacer sleeve DH/Bushing ELB/Power cable tie KB



ELB.../DH...

Type	Order no.	Description	Pack
DH 32/6	87701052	Brass distance sleeve	1
DH 32/8	87701062	Brass distance sleeve	1
ELB / 6	87701050	Brass bushing	1
ELB / 8	87701060	Brass bushing	1
KB 28	87661258	Plastic power cable tie (bundle range approx. 1.57 in (40 mm))	100

Insert to obtain additional levels in pre-defined distances.

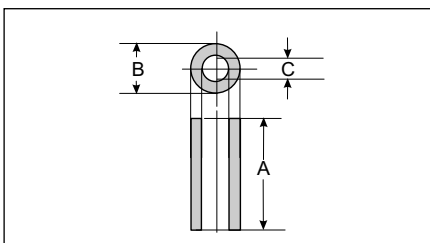

DH...

Type	A inch	B inch	C inch
DH 32/6	1.26	0.47	0.26
DH 32/8	1.26	0.53	0.32



DATA ON THE PLASTIC AND LIGHT METAL PARTS

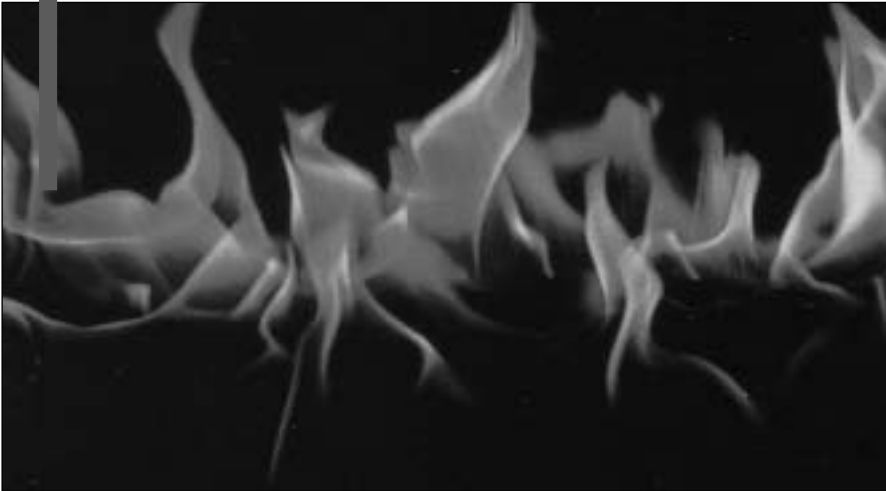



Parts made of plastic

Material data standard material

Mechanical properties		Test	Test value	Unit
Tensile strength (DIN 53 455)		dry	190	N/mm ²
		humidity	120	N/mm ²
Crack resistance (DIN 53 455)		dry	4	%
		humidity	6	%
Elasticity module	Tensile test	dry	7000	N/mm ²
		humidity	10000	N/mm ²
Impact resistance (DIN 53 453)	73.40° F (23° C)	dry	60	kJ/m ²
	73.40° F (23° C)	humidity	75	kJ/m ²
	-40° F (-40° C)	dry	50	kJ/m ²
Creep module E	73.40...122.00° F	humidity	5400	N/mm ²
	248° F (120° C)	dry	2100	N/mm ²
Heat conductivity		-	0.3	W/k x m
Static electricity value (DIN 53 483)		dry	3.8	MHz
		humidity	6.8	MHz
Special volume resistance		dry	10 ¹⁵	Ω x cm
		humidity	10 ¹²	Ω x cm
Impact resistance	Thickness 0.02...0.03 inch	-	80	kV/mm
Surface resistance ROA		dry	10 ¹²	Ω
		humidity	10 ¹⁰	Ω
Moisture absorption	73.40...122.00° F	-	1.8 ± 0.2	%
Temperature limits				
permissible temperature	-22.00 to 212° F			
5000 hours	Up to 275° F (135° C)			
several hours	Up to 338 F (170° C)			
Other properties				
Density	dry	1.4 g/cm ³		
Coefficient of sliding friction	unlubricated	0.3-0.45		
Fire behaviour	DIN VDE 0304 Part 3			
Fire classification acc. to UL	HB			

Murrplastik drag chain has been developed for use in extreme conditions. The standard material is glass fiber reinforced plastic in standard black.

Properties

1. good mechanical strength for strain, pressure, torsion and free running
2. weather resistant
3. Environmental conditions, e.g. in clean rooms and hygienic areas.

We easily meet these requirements through the PA (Polyamide) we have developed. For special applications Murrplastik can also supply modified versions, in most cases.

General

The drag chain plastic is free of halogens, silicones and hard metals such as lead and cadmium. No formaldehydes are used in manufacturing.

The use of plastic drag chains fulfils the requirements of the food industry.

Components made of light metal

Material data standard material

Density	1.4 g/cm ³
Elasticity module	70 kN/mm ²
Electrical conductivity	30–34 m/Wmm ²
Heat conductivity	2.0-2.2 W/k x cm
Coefficient of thermal expansion	23.4 cm/cm k 10 ⁶
Tensile strength	215 N/mm ²
Elongation at break	12 %

The advantage of using light metal for certain parts lies in the combination of its mechanical strength, resistance to chemical attack and its physical properties.

Murrplastik use a special aluminum with the following properties. It stands out due to the following characteristics:

1. light, stable, hard, and smooth
2. looks good
3. very low friction and wear behaviour by the light metal compared with the cable materials
4. does not tend to become brittle at low temperatures
5. sea water resistant

Light metal is used by Murrplastik for the following products:

Cross member profiles and profiles for VAW variable guide channel system.



1.

Burning behaviour

The flame-retardant properties of Murrplastik drag chains meet various classifications:

Test procedures acc. to VDE 0304 Parts 3/5.70,
Classification: IIc

Testing based on "UL 94 – Standard Tests for Flammability of Plastic Materials for Parts in Devices and Appliances“, Classification: 94 HB with 0.13 and 0.06 inch body thicknesses.

Testing based on DIN 4102 "Fire behaviour of building materials and elements", Classification: Building materials class B 2

In case of more stringent applications please contact us.



2.

Radiation resistance

Murrplastik drag chains are very resistant to radiation. In the range of 8×10^6 Gy gamma radiation the mechanical properties change very little.



3.

Vacuum

Murrplastik plastic cable drag chains may be safely used in a vacuum. Gas will only be given off in very low amounts.



4.

Welding flashes and hot sparks

Murrplastik chain provide optimal protection for cables on robotic welding machines. This has been demonstrated both in laboratory testing and numerous references. The material may appear optically impaired but in no way will its function be reduced. The chain has successfully passed tests with middle size flashes at a temperature of 932° C.



5.

Use in EX explosion proof areas

The Murrplastik cable drag chain may be used in explosion proof areas if manufactured to specification with a special material and if the standard regulations are observed. All Murrplastik cable drag chains are certified based on ATEX-Europa guideline 94/9 EG and can be deployed safely in the corresponding areas.



6.

Weatherproof

Murrplastik cable drag chains are suitable for outdoor applications. Experience has shown that the mechanical properties are not impaired.

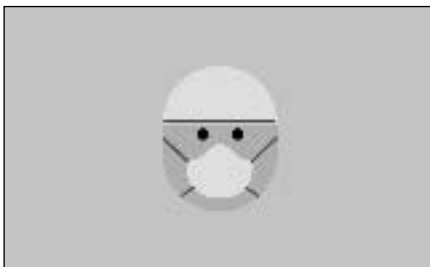

7.

Use in clean rooms

Murrplastik uses a special material. This reduces even further the very low wear of a normal chain. In many applications in which difficult special conditions apply, the cable drag chain can still be used. An intensive test program can be set up to verify its suitability in self-supporting and gliding applications.

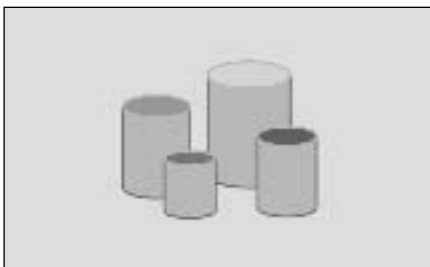

8.

Special colours

By request, we deliver cable drag chain systems made of coloured plastic. Several colours can also be combined where colour-psychological effects are desired. Minimum order quantities and special prices apply.



9.

Use in cold storage

Chain made of a special material can be supplied for use in cold storage.



Chemical resistance

Chemical	Concentration as %	Temperature in °F	Resistance
Acetone	TR		●
Formic acid	10		■
Ammonia, (liquid)	TR	158	■
Ammonia		68	●
Benzine	H	185	●
Benzol	H		●
Bitumen	H		●
Boracic acid, aqueous	H		●
Butyric acid, aqueous	20		●
Calcium chloride	GL	73	●
Hydrogen chloride			●
Chlorine, Chlorine water	H		▲
Chromic acid, aqueous	10		▲
Diesel oil	H		●
Acetic acid, aqueous, concentrated	95		▲
Acetic acid, aqueous	10		■
Ethanol	40		●
Ethyl acetate	TR		●
Paints and lacquers			●
Greases and waxes	H		●
Liquid gas (DIN 51 622)			●
Fluoro hydrocarbons			●
Formaldehyde and polymac.	TR		●
Formaldehyde, aqueous	30		●
Hydraulic oils	H		●
Caustic potash solution	10		●
Potassium chloride, aqueous	10		●
Potassium nitrate, aqueous	10		●
Methyl acetate	TR		●
Lactic	H		●
Lactic acid, aqueous	10		●
Lactic acid	90		▲
Mineral oil	H		●
Sodium carbonate, aqueous	10		●
Oil/edible oil, lubricating oil	H		●
Oleic acid	H		●
Paraffin, Paraffin oil	H		●
Polyester resins	H		●
Propane	TR		●
Mercury	TR		●
Hydrochloric acid, aqueous	≥ 20		◆
Hydrochloric acid	2		▲
Lubricants, edible fats	H		●
Vaseline	H		●
Tartaric acid, aqueous	10		●
Tartaric acid	50		■
Xylene	TR		●

Chemical resistance

Murrplastik cable drag chains are resistant to fuel, lubricants, oil, grease, alcohol, ester, ketone, aliphatic and aromatic hydrocarbons. Oxidising agents and acids are harmful.

The table shows an excerpt of the precise resistance levels to various chemicals.

Please inquire if a particular chemical is not shown.

Explanation of symbols

- resistant
- partially resistant
- ▲ non-resistant
- ◆ soluble

G Saturated liquid aqueous
 H Customary in the trade
 TR Technical pure

All information with respect to the chemical and physical properties of Murrplastik products as well as application advice given verbally, in writing or by tests, is given to the best of our knowledge.

It does not exempt the purchaser from the duty to carry out inspections and tests to determine the exact suitability of the products for the intended use.

The purchaser is solely liable for the application, use, and installation of the products. He must also comply with the legal and official provisions, and observe any industrial property rights of third parties. Our General Terms and Conditions shall apply.

APPENDIX





Sales agencies/Germany



Postcode areas Murrplastik Systemtechnik GmbH
 20095 - 32609 Vertriebsgebiet Nord
 38100 - 38559 Telefon: +49 7191 482-221
 Telefax: +49 7191 482-280
 info@murrplastik.de

Postcode areas Murrplastik Systemtechnik GmbH
 01067 - 06928 Vertriebsgebiet Ost
 07318 - 07989 Telefon: +49 33762 819 74
 08056 - 19417 Telefax: +49 33762 819 75
 36404 - 36469 info@murrplastik.de
 39104 - 39649
 98527 - 99998

Postcode areas Murrplastik Systemtechnik GmbH
 32657 - 35119 Vertriebsgebiet West
 35260 - 35288 Telefon: +49 7191 482-227
 36179 - 36289 Telefax: +49 7191 482-280
 37073 - 37699 info@murrplastik.de
 38640 - 38899
 44135 - 49849
 58089 - 59969

Postcode areas Murrplastik Systemtechnik GmbH
 35216 - 35239 Vertriebsgebiet Süd-West
 35305 - 36169 Telefon: +49 7191 482 -210 -234
 36304 - 36399 Telefax: +49 7191 482-280
 40210 - 42929 info@murrplastik.de
 50126 - 57648
 60308 - 69518
 74706 - 74939
 76726 - 76891
 97900 - 97999

Postcode areas Murrplastik Systemtechnik GmbH
 86720 - 86759 Vertriebsgebiet Nord-Bayern
 90402 - 93499 Telefon: +49 7191 482-226
 95028 - 97896 Telefax: +49 7191 482-280
 info@murrplastik.de

Postcode areas Murrplastik Systemtechnik GmbH
 70173 - 74679 Vertriebsgebiet Süd
 75015 - 76709 Telefon: +49 7191 482-220 -233
 -216 -247
 77652 - 79879 Telefax: +49 7191 482-280
 88045 - 88099 info@murrplastik.de
 88212 - 89299
 89518 - 89619

Postcode areas Murrplastik Systemtechnik GmbH
 80331 - 86706 Vertriebsgebiet Süd-Bayern
 86807 - 87789 Telefon: +49 7191 482-237
 88131 - 88179 Telefax: +49 7191 482-280
 89312 - 89447 info@murrplastik.de
 94032 - 94579

Sales agencies/abroad

Argentina



Nakase SRL
 Calle 49, Nr. 5764/66, B1653AOX
 Villa Ballester, Provincia Buenos Aires
 Telefon: +54 11 476 842 42
 Telefax: +54 11 476 842 421 11
 nakase@nakase.com;
 ventas@nakase.com
 www.nakase.com

Australia



N.L. Tucker & Associates
 Pty. Ltd.
 12 b Pitt Way
 Booragoon, Perth,
 Western Australia 6154
 Telefon: +61 89 330 79 11
 Telefax: +61 89 317 15 44
 sales@nltucker.com.au

N.L. Tucker & Associates
 Pty. Ltd.
 50 Marni Street
 Dandenong South Victoria 3175
 Telefon: +61 39 706 66 91
 Telefax: +61 39 706 66 92
 vicsales@nltucker.com.au

Austria



Murrplastik Systemtechnik GmbH
 Fabrikstraße 10
 71570 Oppenweiler (Deutschland)
 Telefon: +43 732 660 870
 Telefax: +43 732 660 872
 info@murrplastik.at
 www.murrplastik.at

Belgium



ATEM NV/SA
 Bedrijven Park De Veert 4
 2830 Willebroek
 Telefon: +32 38 661 800
 Telefax: +32 38 661 828
 info@atem.be

Brazil



Murrelektronik do Brasil Ltda.
 Av. Interlagos 3493
 04661-200 São Paulo
 Telefon: +55 11 563 110 17
 Telefax: +55 11 563 109 00
 info@murrelektronik.com.br
 www.murr.com.br

China



Murrplastik Asia Co., Ltd.
 1802 Rm. No. 218
 Hengfeng Rd.
 200070 Shanghai
 Telefon: +86 21 512 869 25
 Telefax: +86 21 512 869 29
 info@murrplastik.com.cn
 www.murrplastik.com.cn

Czech Republic



Schmachtl CZ spol. s.r.o.
 Elektrotechnika
 Vestec 185
 252 42 Jesenice
 Telefon: +422 440 015 00
 Telefax: +422 449 107 00
 office@schmachtl.cz
 www.schmachtl.cz

Denmark



Brødrene Eegholm A/S
 Grundtvigs Allé 165-169
 6400 Sønderborg
 Telefon: +45 73 121 212
 Telefax: +45 73 121 213
 eegholm@eegholm.dk

Finland



Murrelektronik Oy
 Koukkukatu 1
 15700 Lahti
 Telefon: +358 388 240 00
 Telefax: +358 388 240 40
 myynti@murrelektronik.fi

France



Murrtechnic S.à.r.l
 Zone Industrielle Sud
 6 rue Manurhin
 B.P. 62
 68120 Richwiller
 Telefon: +33 389 570 010
 Telefax: +33 389 530 966
 murrtechnic@murrtechnic.fr
 www.murrtechnic.eu

Great Britain



Murrelektronik Ltd.
 Albion Street
 Pendlebury Industrial Estate, Swinton
 Manchester M27 4FG
 Telefon: +44 161 728 31 33
 Telefax: +44 161 728 31 30
 sales@murrelektronik.co.uk
 www.murrelektronik.co.uk

Greece



2 Kappa Ltd.
 Stadiou 40
 57009 Thessaloniki (Kalahori)
 Telefon: +30 2310 775 512
 Telefax: +30 2310 775 514
 info@2kappa.gr

Hong Kong





















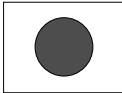



Worldtex & Co. (HK) Ltd.
 Unit 11, 11/F., Tins Enterprises Center,
 777 Lai Chi Kok Rd., Cheung Sha Wan,
 Kowloon, Hong Kong
 Telefon: +852 2781 18 60
 Telefax: +852 2781 47 33
 info@worldtex-co.com.hk

Hungary

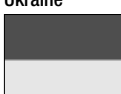

Technika G.K.M. Kft.
 Csiki u. 1.
 2040 Budaörs
 Telefon: +36 23 424 888
 Telefax: +36 23 424 858
 wieland@technikagkm.hu
 www.technikagkm.hu

Sales agencies/abroad

	<p>India Rajdeep Automation Pvt Ltd Survey # 143, Pune Sinhaghad Road Vadgaon Dhayri Pune 411 041 Telefon: +91 22 238 280 92 Telefax: +91 22 238 932 52 info@rajdeep.in www.rajdeep.in</p>		<p>Portugal F.Fonseca, S.A. Rua João Francisco do Casal, 87/89 Apartado 3003 - Esgueira 3801-997 Aveiro Telefon: +351 234 303 900 Telefax: +351 234 303 910 ffonseca@ffonseca.com</p>		<p>Sweden J.Y. Automation System AB Vikhemsvägen 9 241 38 Eslov Telefon: +46 413 692 20 Telefax: +46 413 692 21 info@automationsystem.se www.automationsystem.se</p>
	<p>Israel EL-KAM Agencies and Trading Ltd. 26, Ha'ta'as St. 44425 Kfar-Saba Telefon: +972 9 765 88 08 Telefax: +972 9 765 85 45 el-kam@el-kam.com</p>		<p>Singapore Balluff Asia Pte. Ltd. Bik 1004, Toa Payoh Industrial Park Lorong 8, # 03 - 14 89 Singapore 31 90 76 Telefon: +65 6 252 43 84 Telefax: +65 6 252 90 60 balluff@balluff.com.sg</p>		<p>Switzerland Murrplastik AG Ratihard 40 8253 Willisdorf Telefon: +41 52 646 06 46 Telefax: +41 52 646 06 40 info@murrplastik.ch www.murrplastik.ch</p>
	<p>Italy Murrplastik Italia S.r.l. Via Circo, 18 20123 - Milano Telefon: +39 02 856 805 70 Telefax: +39 02 805 034 69 info@murrplastik.it www.murrplastik.it</p>		<p>Slovakia SCHMACHTL SK s.r.o. Valchárska 3 821 09 Bratislava Telefon: +42 12 582 756 11 Telefax: +42 12 582 756 01 office@schmacthl.sk</p>		<p>Taiwan Lintronix Co., Ltd. 4F, No. 651-6, Chung Cheng Road, 242 Hsin Chuang Taipei, Taiwan Telefon: +886 2 290 816 66 Telefax: +886 2 290 816 78 info@lintronix.com.tw www.lintronix.com.tw</p>
	<p>Japan Kitagawa Industries Co. Ltd. Sales Dept. attention: Mr. S. Nishikawa Sengoku Bldg. 6F 2-4-15 Nihonbashi-Muromachi Chuo-Ku, TOKYO 103-0022 Telefon: +81 3 324 113 03 Telefax: +81 3 525 564 35 nisikawa@kitagawa-ind.co.jp www.kitagawa-ind.com</p>		<p>Slovenia Senzorji SB d.o.o. Ulica Kirbisevih 53a 2204 Miklavz na Dravskem polju Telefon: +386 2 629 03 00 Telefax: +386 2 629 03 02 senzorji.sb@siol.net</p>		<p>Thailand Autonix Co., Ltd. 3.FL., 124 Chung-Cheng Road, Shihlin 11145 Taipei, Taiwan Telefon: +886 2 886 612 34 Telefax: +886 2 886 612 39 day111@ms23.hinet.net</p>
	<p>Lithuania HIDROTEKA Engineering Services Chemijos 29E 51333 Kaunas Telefon: +370 37 352 195 Telefax: +370 37 760 500 arunas@hidroteka.lt www.hidroteka.lt</p>		<p>South Africa Innomatic 42 Monte Carlo Crescent Kyalami Park, Midrand Gauteng Telefon: +27 11 466 01 74 Telefax: +27 11 466 02 23 sales@innomatic.co.za</p>		<p>Turkey Compomax Company Ltd. 16 Soi Ekamai 4, Sukhumvit 63 Rd. Prakanongnua, Vadhana Bangkok, 10110 Telefon: +66 2 726 95 95 Telefax: +66 2 726 98 60 info@compomax.co.th</p>
	<p>Netherlands Murrelektronik B.V. Meerpaal 1 4904 SK Oosterhout (NB) Telefon: +31 162 492 411 Telefax: +31 162 492 415 sales@murrelektronik.nl www.murrelektronik.nl</p>		<p>South Korea KPI Co. Ltd. B-123 neo business center 14-7 Pal Yong-Dong Kyung Sang Nam-Do 641-465 Chang Won City Telefon: +82 551 284 88 25 Telefax: +82 551 287 79 54 kpi@kpi-korea.com</p>		<p>Ukraine Pinar Mühendislik LTD. ŞTĐ. Perpa Ticaret Merkezi A Blok Kat 11 No:1477 80270 Okmeydani-Istanbul Telefon: +90 212 220 02 77 Telefax: +90 212 220 13 16 info@pinarmuh.com www.pinarmuh.com.tr</p>
	<p>Norway Murrelektronik A/S Kartverksveien 12 3504 Honefoss Telefon: +47 32 179 080 Telefax: +47 32 179 090 post@murrelektronik.no www.murrelektronik.no</p>		<p>Spain Murrplastik S.L. Paseo Ubarburu, 76 Pabellón 34, poligono 27 20014 San Sebastián Telefon: +34 943 444 837 Telefax: +34 943 472 895 info@murrplastik.es www.murrplastik.es</p>		<p>USA Murrplastik Systems Inc. 2367 North Penn Road Suite 200 Hatfield, PA 19440 Telefon: +1 215 822 76 25 Telefax: +1 215 822 76 26 cablegmt@murrplastik.com www.murrplastik.com</p>
	<p>Poland POLTECHNIK Sp. z o.o. ul. Trojkatna 1 54-414 Wrocław Telefon: +48 71 353 86 94 Telefax: +48 71 353 86 96 info@poltechnik.pl www.poltechnik.pl</p>		<p>USA Murrplastik Systems Inc. 2367 North Penn Road Suite 200 Hatfield, PA 19440 Telefon: +1 215 822 76 25 Telefax: +1 215 822 76 26 cablegmt@murrplastik.com www.murrplastik.com</p>		<p>USA Murrplastik Systems Inc. 2367 North Penn Road Suite 200 Hatfield, PA 19440 Telefon: +1 215 822 76 25 Telefax: +1 215 822 76 26 cablegmt@murrplastik.com www.murrplastik.com</p>

All information with respect to the physical and chemical properties of Murrplastik products as well as application advice given verbally, in writing or by tests, is given to the best of our knowledge.

It does not exempt the purchaser from the duty to carry out inspections and tests to determine the exact suitability of the products for the intended use.

The purchaser is solely liable for the application, use, and installation of the products. He must also comply with the legal and official provisions, and observe any industrial property rights of third parties.

Our General Terms and Conditions apply.

Subject to technical alterations.



Head Office

Germany

Murrplastik Systemtechnik GmbH
Postfach 1143
71567 Oppenweiler
☎ +49 7191 48 20
✉ +49 7191 482 280
www.murrplastik.de
info@murrplastik.de

Austria

Murrplastik Systemtechnik GmbH
☎ +43 732 660 870
✉ +43 732 660 872
www.murrplastik.at
info@murrplastik.at

China

Murrplastik Asia Co., Ltd.
1802 Rm. No. 218
Hengfeng Rd.
200070 Shanghai
☎ +86 21 512 869 25
✉ +86 21 512 869 29
www.murrplastik.com.cn
info@murrplastik.com.cn

France

Murrtechnic S.à.r.l
Zone industrielle Sud, 6 rue Manurhin
B.P. 62, 68120 Richwiller
☎ +33 389 570 010
✉ +33 389 530 966
www.murrtechnic.eu
murrtechnic@murrtechnic.fr

Italy

Murrplastik Italia S.r.l.
Via Circo, 18
20123 Milano
☎ +39 02 856 805 70
✉ +39 02 805 034 69
www.murrplastik.it
info@murrplastik.it

Spain

Murrplastik S.L.
Paseo Ubarburu, 76
Pabellón 34, polígono 27
20014 San Sebastián
☎ +34 943 444 837
✉ +34 943 472 895
www.murrplastik.es
info@murrplastik.es

Switzerland

Murrplastik AG
Ratihard 40
8253 Willisdorf
☎ +41 52 646 06 46
✉ +41 52 646 06 40
www.murrplastik.ch
info@murrplastik.ch

USA

Murrplastik Systems Inc.
2367 North Penn Road
Suite 200
Hatfield, PA 19440
☎ +1 215 822 76 25
✉ +1 215 822 76 26
www.murrplastik.com
cablegmt@murrplastik.com



1001RA



MP8903804000