

## DATASHEET

# TPM2840 Silicon Schottky Diode

## Description

- DNmicron's TPM2840 series have good RF application performance.
- For mixer applications in VHF/UHF range.
- Used as DC bias detector diode.
- For high-speed switching application.
- The series of diodes could be packaged in a variety of formats, we assure that when two or more diodes are mounted into a single surface mount package, they are taken from adjacent sites on the wafer, assuring the highest possible degree of match.

## Features

- Multi packages SOD-523, SOT-23
- Tape and Reel Options Available
- Pb-free (RoHS compliant) package
- High matching of diode in package



ESD WARNING:

Handling Precautions Should Be Taken To Avoid Static Discharge.

## Part Number and Configuration

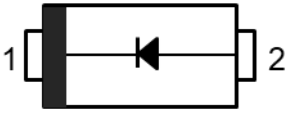
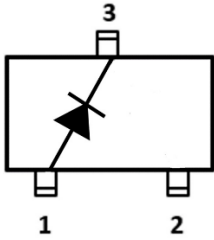
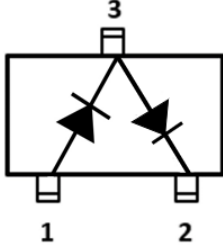
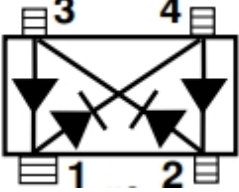
TPM2840 -01 SOD-523	TPM2840 -02 SOT-23	TPM2840 -03 SOT-23
		
TPM2840 -09 SOT-143		
		

**Maximum Ratings,  $T_c=+25^\circ\text{C}$** 

Parameter	Symbol	Value	Unit
Diode reverse voltage	$V_R$	5	V
Forward current	$I_F$	130	mA
Operating temperature	$T_{op}$	-55~125	$^\circ\text{C}$
Storage temperature	$T_{stg}$	-55~150	$^\circ\text{C}$

**Electrical Specifications,  $T_c=+25^\circ\text{C}$** 

Parameter	Symbol	Values			Unit
		Min.	TYP.	Max.	

**DC Characteristics**

Breakdown voltage $I_{(BR)}=10\ \mu\text{A}$	$V_{(BR)}$	5	7	-	V
Reverse current $V_R=3\ \text{V}$ $V_R=4\ \text{V}$ $V_R=3\ \text{V}, T_c=60\ \text{ms}$	$I_R$	-	0.7 1.1 3.8	-	$\mu\text{A}$
Forward voltage $I_F=0.1\ \text{mA}$ $I_F=1\ \text{mA}$ $I_F=10\ \text{mA}$	$V_F$	-	194 264 375	-	mV
Forward voltage matching $I_F=1\ \text{mA}$	$\Delta V_F$	-		2	mV

**AC Characteristics**

Diode capacitance $V_R=0, f=1\ \text{MHz}$	$C_T$	-	0.48	-	pF
Differential forward resistance $I_F=5\ \text{mA}, f=10\ \text{kHz}$	$R_F$	-	9	-	$\Omega$

## Typical Performance

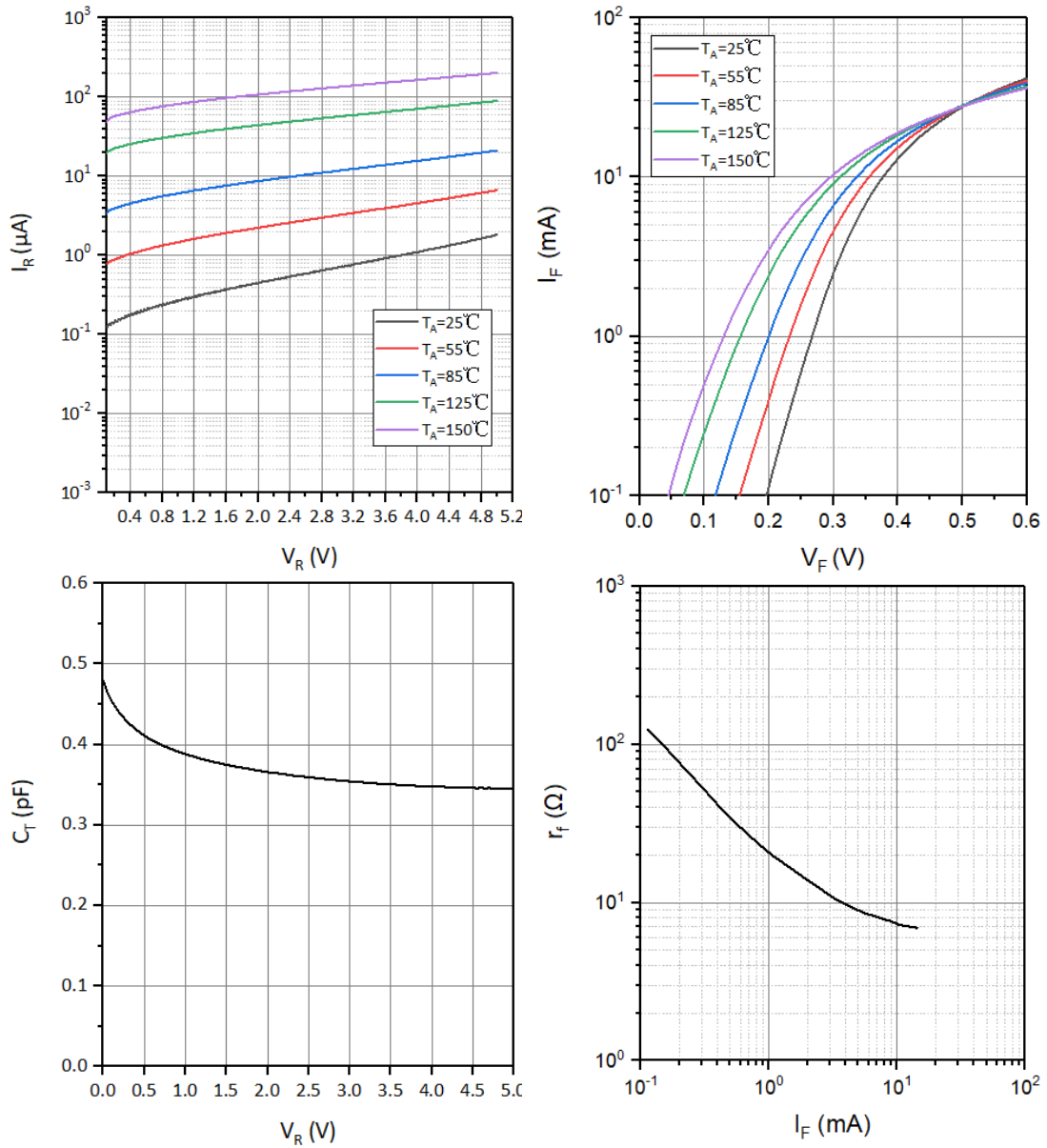

## Package Dimension Drawing

## SOT-23

Symbol	Dimensions (mm)	
	Min	Max
A1	0.04	0.10
A2	1.00	1.20
D	2.82	3.02
E	2.60	3.00
E1	1.50	1.70
e	0.95BSC	
L1	0.60REF	

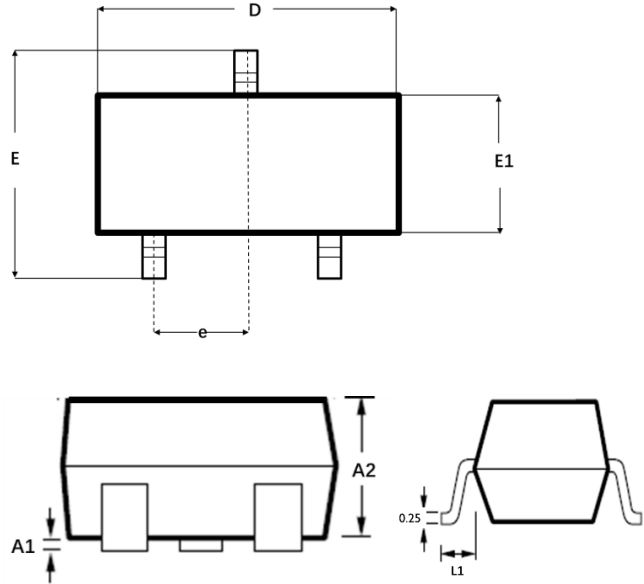

## SOD-523

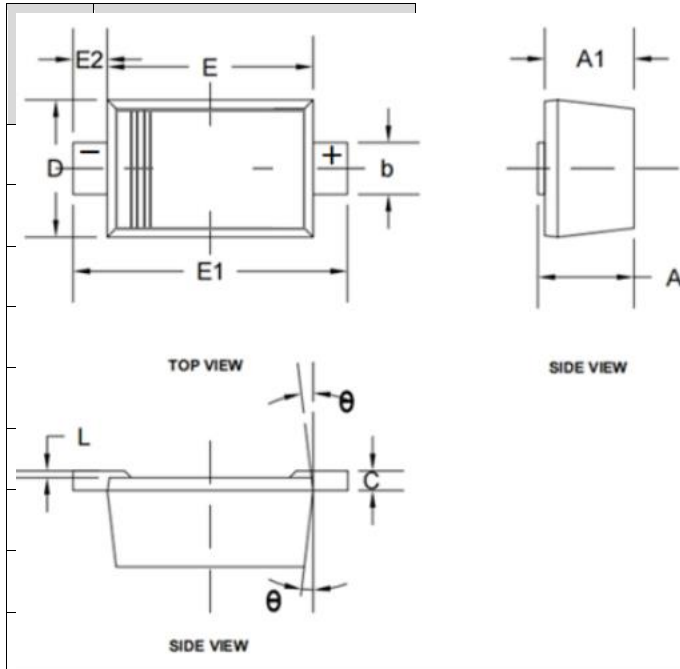

## SOT-143

Sym bol	Dimensions (mm)		
	Min	TYP	Max
A	0.950	1.125	1.300
A1	0.000	0.050	0.100
A2	0.900	1.050	1.200
b	0.300	0.400	0.500
b1	0.750	0.850	0.950
c	0.080	0.115	0.150
D	2.800	2.900	3.000
d	0.200TYP		
E	1.200	1.300	1.400
E1	2.250	2.400	2.550
e	0.950TYP		
e1	1.800	1.900	2.000
L	0.550TYP		
L1	0.300	0.400	0.500
$\theta$	0°	4°	8°

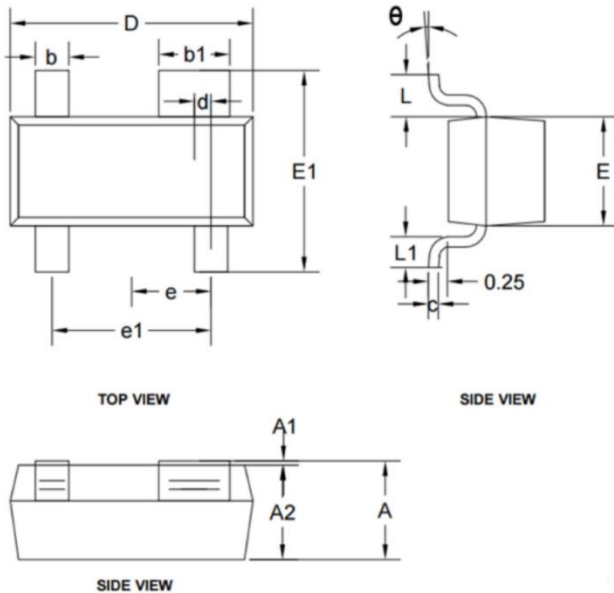



## Disclaimer

### General Information

The information in this datasheet is provided for reference only and is subject to change without notice. While efforts have been made to ensure accuracy, DNMICRON, INC. makes no warranties regarding the completeness or correctness of the data. Users are advised to verify product suitability for their specific applications.

### Application Notes

The device's electrical characteristics and performance data are general guidelines. Any application-specific configurations must be independently verified. DNMICRON, INC. is not responsible for misuse or damage resulting from improper use or incorrect application.

### No Liability

DNMICRON, INC. is not liable for any direct, indirect, or consequential damages arising from the use of the product. The user assumes all risks associated with the device's use in their systems.

### Warranty

Products are covered by the standard warranty policy. For warranty terms and conditions, refer to the DNMICRON, INC. Warranty Policy.

### Compliance

Users are responsible for ensuring that their use of the product complies with all applicable laws and regulations. The product may comply with RoHS and REACH standards.

### Changes

DNMICRON, INC. reserves the right to update or discontinue the datasheet or product without notice. Updated information will be provided via the official website.

### Contact Information

For further information, please contact:

Website: [www.dnmicron.com](http://www.dnmicron.com)

Email: [sales@dnmicron.com](mailto:sales@dnmicron.com)