

CLIFF

USBC 3.2 F-M + USB3.0 A-A FEEDTHROUGH CONNECTOR

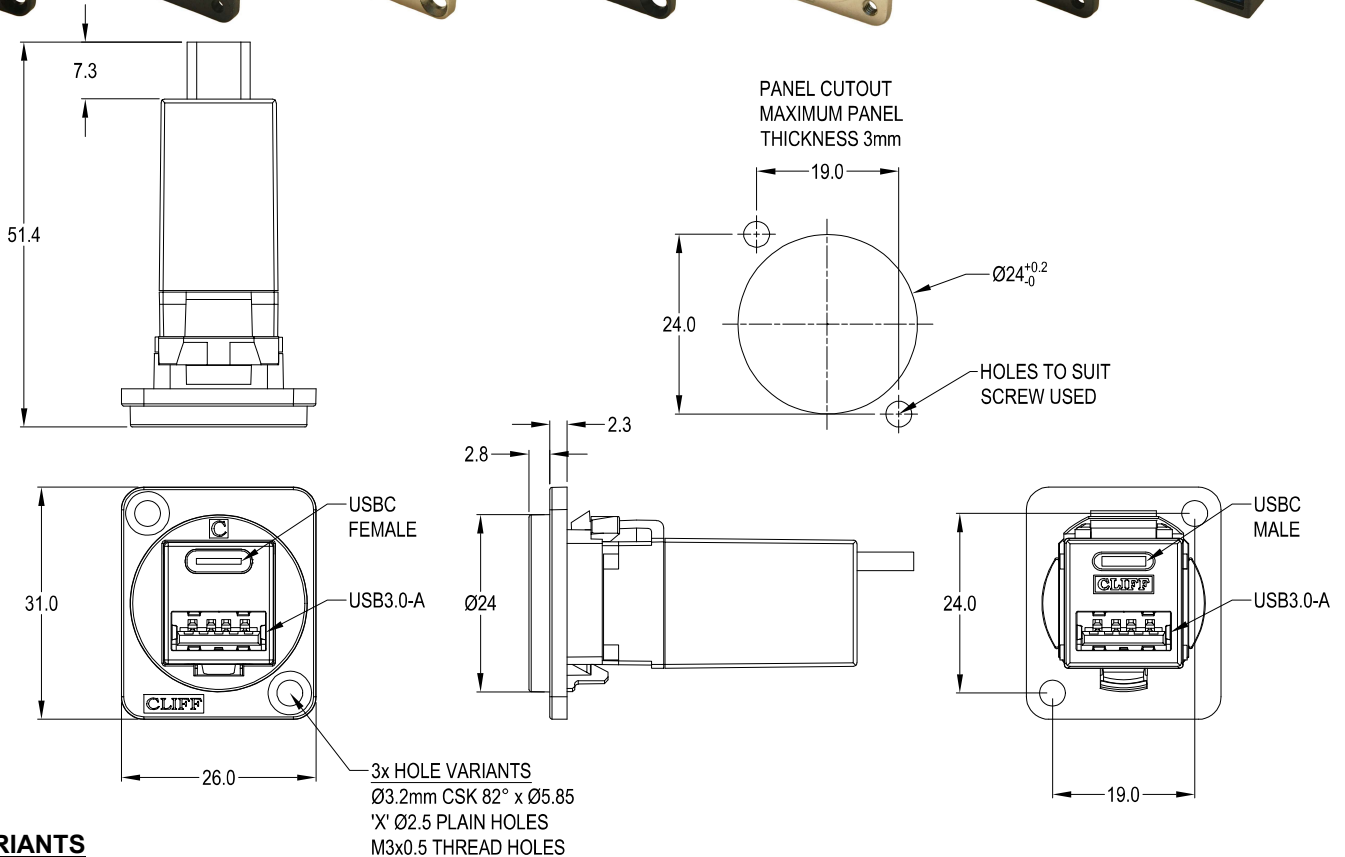

VARIANTS

Part No.

CP30235	USBC 3.2 F-M + USB3.0 A-A Black plastic frame, CSK holes
CP30235M	USBC 3.2 F-M + USB3.0 A-A Nickel plated metal frame, CSK holes
CP30235M3	USBC 3.2 F-M + USB3.0 A-A Nickel plated metal frame, M3 holes
CP30235MB	USBC 3.2 F-M + USB3.0 A-A Black metal frame, CSK holes
CP30235M3B	USBC 3.2 F-M + USB3.0 A-A Black metal frame, M3 holes
CP30235X	USBC 3.2 F-M + USB3.0 A-A Black plastic frame, PLAIN holes

Feedthrough Features

- Fits standard XLR Ø24mm cutout.
- No soldering or punch termination. Use standard cable for each connector style.
- Front or rear mounted.
- Low rear profile

General:

Please note: Functionality is affected by cable quality, length and cable wiring configuration.

Material:

1. Insert: ABS UL94 V-0 - Black
2. FT Frame: Polyamide UL94-V2 - Black or Nickel / Black Plated Zinc Diecast
3. USB Connectors: Composite
4. Contacts: Gold Plated
5. Operating Temperature: -25°C to 70°C

Specification USBC 3.2 F-M

1. Current rating: 5A
2. Life Cycles: 10,000x insertions

Specification USB 3.0

1. Current rating: 1.5A
2. Life Cycles: 1,500x insertions