

| No. | PARTS NAME | MATERIAL | SIZE | TREATMENT | REMARKS | AMOUNT |
|-----|------------------------|----------|-------|------------|---------|--------|
| 1 | Printed board terminal | Brass | t=1.2 | Tin-plated | | 1 |
| | | | | | | |
| | | | | | | |
| | | | | | | |

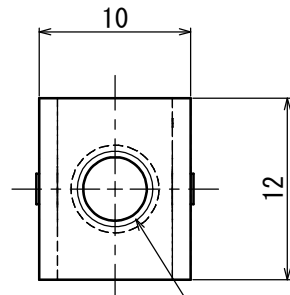

M5 Burring tap

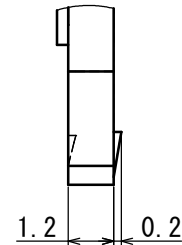

Detail of view A(5/1)

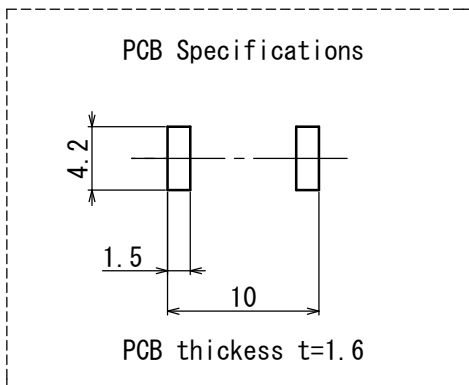
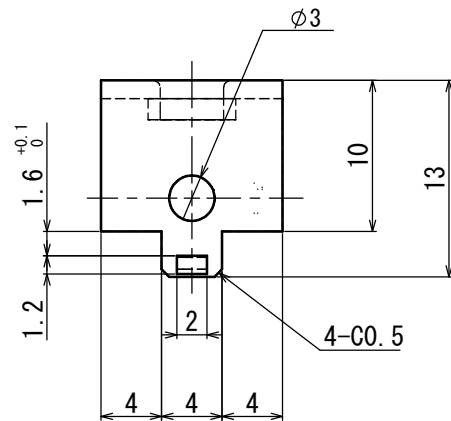
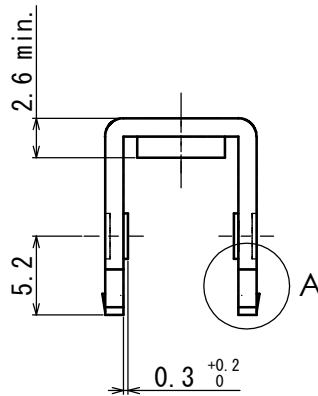

Ordering form : F4076D (Type No.)

※Display it on the name of article label of a packing box as a 「RoHS2 Compliance」
 ※The M5 burring section shall withstand a tightening torque of 4.0 N·m (40 kgf·cm)

| | | | |
|----------------------------|---------------------|-------------------|--------------------|
| RATING | 40 ~ 70 A | | |
| Screw diament | M5 | | |
| Usable electric wire | 40 A | 50 A | 70 A |
| Conforting wire | 5.5 mm ² | 8 mm ² | 14 mm ² |
| Recommended crimp terminal | R5.5-5 | R8-5 | R14-5 |

| REVISION | SIGN | DATE | CONTENT | AUTHOR | APPROVER | TOLERANCE UNLESS OTHERWISE SPECIFIED | DWG No. | 105535-8 | | DESIGN. | | | | |
|----------|------|------|---------|--------|----------|--------------------------------------|--|----------|--------|---------|----------|----------|----------|---------|
| | | | | | | | ±0.5 | TYPE. | F4076D | | DWG. | kuwabara | 04.2.10 | |
| | | | | | | | 3RD ANGLE PROJECTION | UNIT | mm | SCALE | 2/1 | CHK. | kudamatu | 04.2.13 |
| | | | | | | | | | | APPRD | kudamatu | 04.2.13 | | |
| | | | | | | |  FUJICON CO., LTD | | | | | | | |